

nuwave[®]
— LIVE WELL FOR LESS —

NuWave BruHub™ 3-in-1 Coffee Maker



Owner's Manual

nuwave®

LIVE WELL FOR LESS

NuWave Brio® 6-Qt Digital Air Fryer



NuWave Oven® Pro Plus



NuWave Brio® 6Q Digital Air Fryer

Super-heated air cooks your food to crispy, tender perfection. The digital touch screen gives you precise temperature control.

NuWave Oven® Pro Plus

Cook healthier meals faster and more efficiently with Triple Combo Cooking Power.

NuWave PIC (Precision Induction Cooktop)

Cook faster, safer, and more efficiently than you ever could on your gas or electric stovetop.

For more about our innovative products, visit:

**NuWave Nutri-Pot® 6Q
Digital Pressure Cooker**



**NuWave Medley®
Digital Skillet**



NuWave PIC®



**NuWave Nutri-Pot® 6Q
Digital Pressure Cooker**

Easily cook rice, poultry, vegetables and more all with the press of a button! The Nutri-Pot's safety release valve and hinged lid make for convenient and safe operation.

**NuWave Medley®
Digital Skillet**

Coated with Duralon® Healthy Ceramic Non-Stick coating for easy cleanup. Includes a premium tempered, vented glass lid.

NuWaveNow.com

 1-877-689-2838

nuwave®

LIVE WELL FOR LESS

NuWave Flavor-Lockers® with Vacuum-Seal Technology



NuWave Flavor-Lockers® with Vacuum-Seal Technology

Keep food fresh for up to 21 days!
Slow the growth of mold by removing
trapped oxygen with a few easy pumps.

NuWave Duralon® Healthy Ceramic Non-Stick Cookware

Coated with Duralon Healthy
Ceramic Non-Stick coating for
easy cleanup, this versatile
cookware is perfect for use in
ovens or on gas, electric, and
even induction cooktops.

For more about our innovative products, visit:

Nutri-Master® Slow Juicer

**NuWave Duralon® Healthy Ceramic
Non-Stick Cookware**



NuWave Nutri-Master® Slow Juicer

The Nutri-Master, with a low 48 RPM, is both incredibly quiet and powerful enough to extract juice from nuts and hard vegetables.

NuWaveNow.com

 1-877-689-2838

TABLE OF CONTENTS

OWNER'S MANUAL

Important Safeguards	6-7
Save These Instructions	7
Parts.....	8-9
Before First Use	10
Assembly	11-14
Functions	15-16
Insert & Beverage Selection Charts.....	17
Cleaning and Maintenance	18-20
Troubleshooting	21-22
Warranty	23

IMPORTANT SAFEGUARDS

When using electrical appliances, basic safety precautions should always be followed including the following:

1. Read all instructions.
2. Close supervision is necessary when any appliance is used by or near children.
3. Do not touch hot surfaces. Care must be taken as burns can occur from touching hot parts of the coffee maker.
4. To protect against electric shock, do not place cord, plug, or base in water or other liquid.
5. Unplug from outlet when the coffee maker is not in use and allow to cool before cleaning.
6. Only operate the coffee maker on flat surface, away from the edge of counter.
7. Do not operate appliance with a damaged supply cord or plug, or after the appliance malfunctions, is dropped or is damaged in any manner. Supply cord replacement and repairs must be conducted by the manufacturer, its service agent, or similarly qualified persons.
Call Customer Service at 1-877-689-2838 or email help@nuwavenow.com for information on repairs.
8. The use of accessory attachments not recommended by the appliance manufacturer may result in fire, electrical shock, or bodily injury up to and including death.
9. Do not use outdoors.
10. Do not use appliance for other than intended use.

IMPORTANT SAFEGUARDS

11. Do not let cord hang over edge of table or counter or touch hot surfaces, including stove.
12. Do not place coffee maker on or near a gas or electric burner or in an oven.
13. To disconnect coffee maker, press the power button off and then remove plug from wall outlet.
14. **WARNING!** To reduce the risk of fire or electric shock, do not remove the bottom cover.
15. Do not open lid during a brewing cycle.
16. The Single Serve Insert contains sharp pieces! Use caution when assembling, disassembling, or cleaning parts.

SAVE THESE INSTRUCTIONS

Other Consumer Safety Information

This appliance is intended for household use only.

- a) A short power-supply cord (or detachable power-supply cord) is provided to reduce risks resulting from becoming entangled in or tripping over a longer cord.
- b) Longer detachable power-supply cords or extension cords are available and may be used if care is exercised in their use.
- c) If a long detachable power-supply cord or extension cord is used:
 - 1) The marked electrical rating of the detachable power-supply cord or extension cord should be at least as great as the electrical rating of the appliance;
 - 2) If the appliance is of the grounded type, the extension cord should be a grounding-type 3-wire cored; and
 - 3) The longer cord should be arranged so that it will not drape over the counter top or table to where it can be pulled on by children or tripped over.

PARTS FOR YOUR NUWAVE BRUHUB™

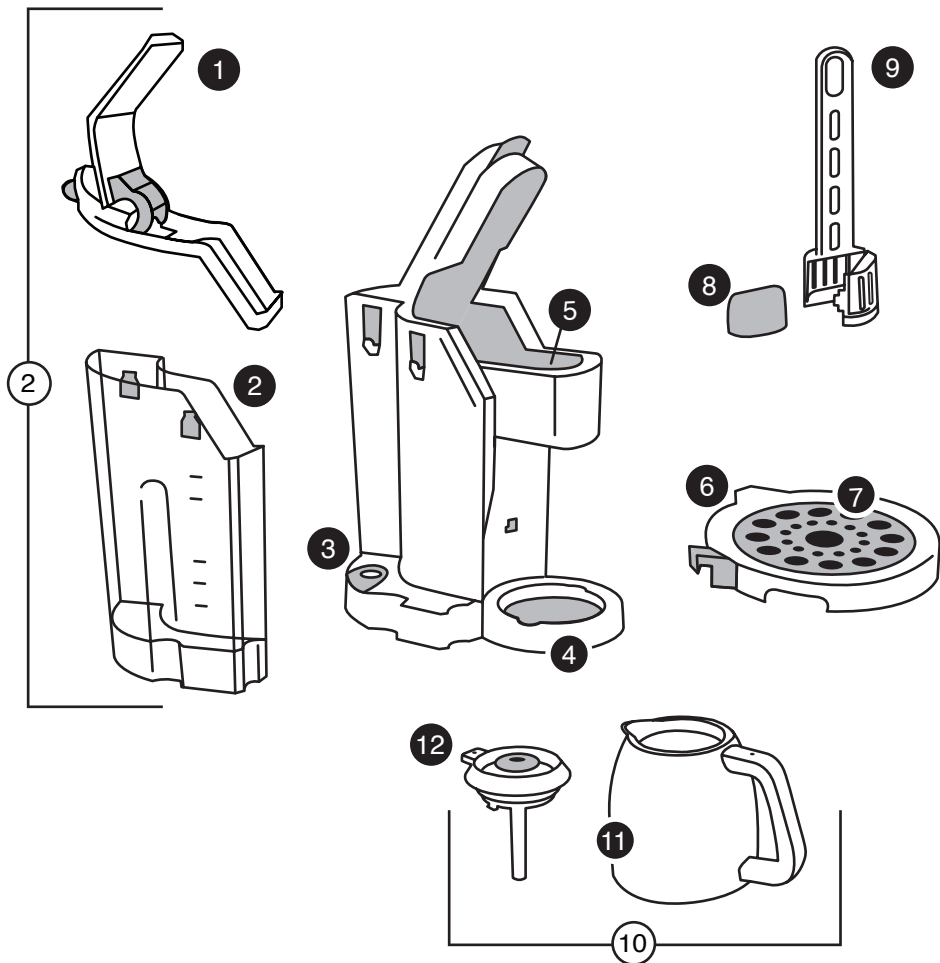

- 1 Tank Lid**
- 2 Water Tank**
Part #: 451201
- 3 BruHub™ Base**
Part #: 45110
- 4 Drip Tray Base**
Part #: 451213
- 5 Insert Chamber**
- 6 Mug Tray**
Part #: 451214
- 7 Screen**
Part #: 45126
- 8 Charcoal Filter**
Part #: 45116
- 9 Charcoal Filter Holder**
Part #: 451205
- 10 Plastic Thermal Carafe**
Part #: 45121
SS Thermal Carafe
Part #: 45131 (optional)
- 11 Carafe Base**
Part #: 45121A
- 12 Carafe Lid**
Part #: 45121B

PARTS FOR YOUR NUWAVE BRUHUB™ (Continued)

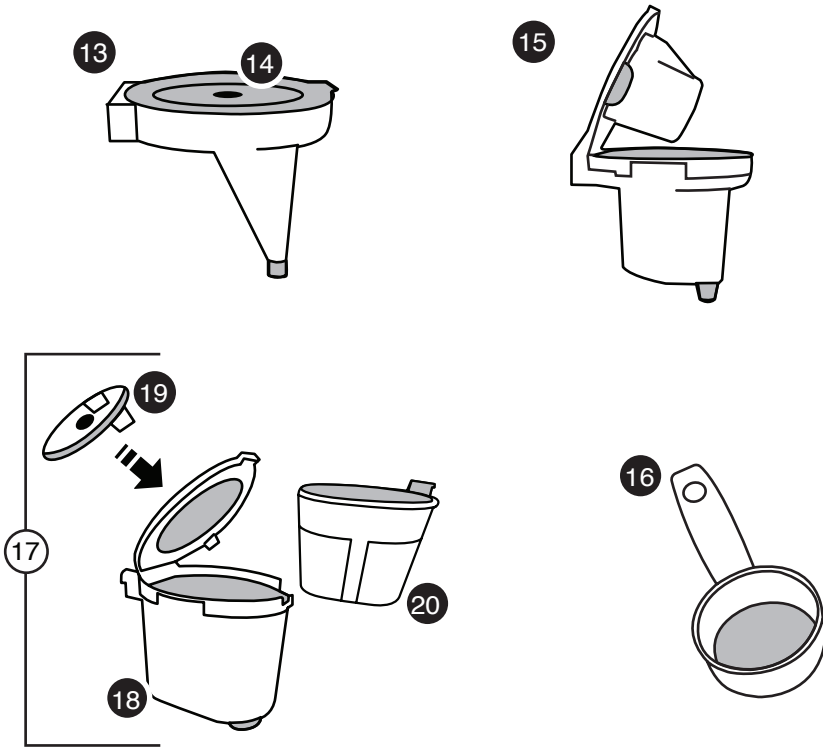

13 Hot Water Insert
Part #: 451204

14 Hot Water Cap

15 Single Serve Insert
Part #: 451202

16 Coffee Scooper
Part #: 45129

17 Custom Brew Insert with Filter Basket
Part #: 451203

18 Custom Brew Insert

19 Custom Brew Cap

20 Custom Brew Filter Basket

BEFORE FIRST USE

Before first use or when the appliance has not been used for an extended period of time, run a cleansing brew at least once with water only:

1. Fill the Water Tank to the MAX Fill Line.
 - Water Tank can be filled while in the unit or detached.

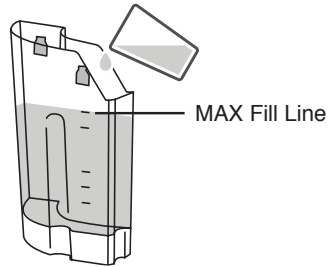

2. Insert Hot Water Insert into the Insert Chamber.
 - See Assembly for the Hot Water Insert on page 14.

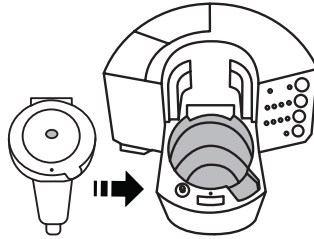

3. Set full-sized Carafe on the Drip Tray Base.

4. Press "Power" to preheat.

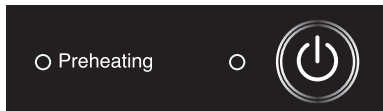

5. Select "hot water" for the coffee selection.



6. Select "carafe" for size selection.

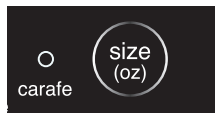

7. Press "brew".
 - Repeat steps 1-7.



CHARCOAL FILTER HOLDER ASSEMBLY

For additional water purification, use the supplied (optional) Charcoal Filter Holder with Filter. Note: The coffee maker will still operate without Charcoal Filter Holder installed.

1. Before first use, apply pressure to release tab to open Charcoal Filter Holder compartment and remove Charcoal Filter.

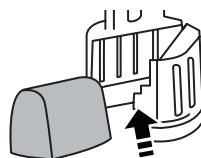

2. Flush Filter by running under cold tap water for 1-3 minutes before initial use. After flushing, allow the Filter to drain completely.

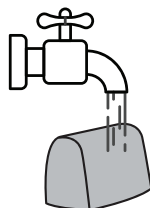

3. Carefully place Filter back into compartment and snap to close.

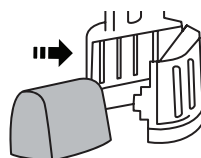

- Flat side (base) of cartridge must face down inside Filter Holder compartment.

4. Insert the Charcoal Filter Holder into the Water Tank. The Filter Holder's base should sit firmly into the channel.

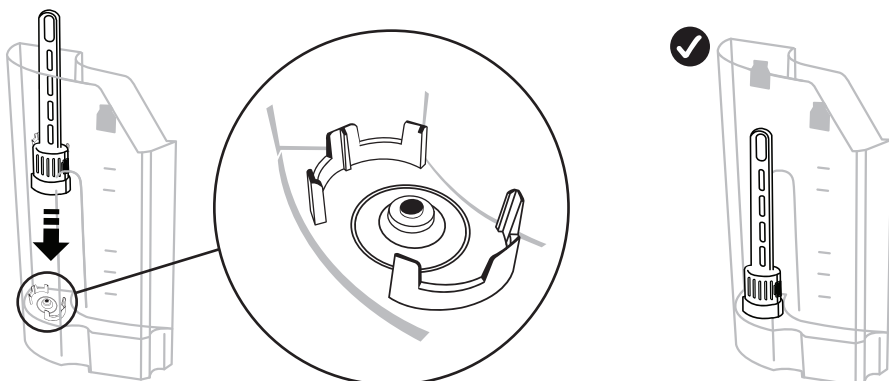

WATER COMPARTMENT

Fill water directly in the Water Tank when attached, or remove first.

To fill directly in the Water Tank:

1. Lift the Water Tank Lid up and pour in water to appropriate fill line.
2. Close the Water Tank Lid.

• Coffee maker will not operate when tank is removed or when there is no water.

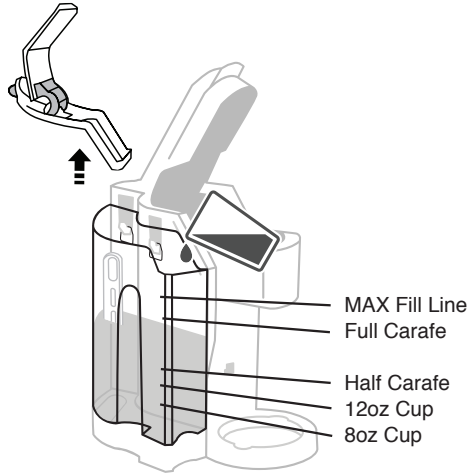

To fill Water Tank when removed:

1. Lift Water Tank Lid and place to the side.
2. Lift Water Tank up to remove from the side.
3. Fill to appropriate fill line.
4. Slide Water Tank straight down, ensuring the hooks fit snug with Water Tank.
5. Place lid back on top of Water Tank.

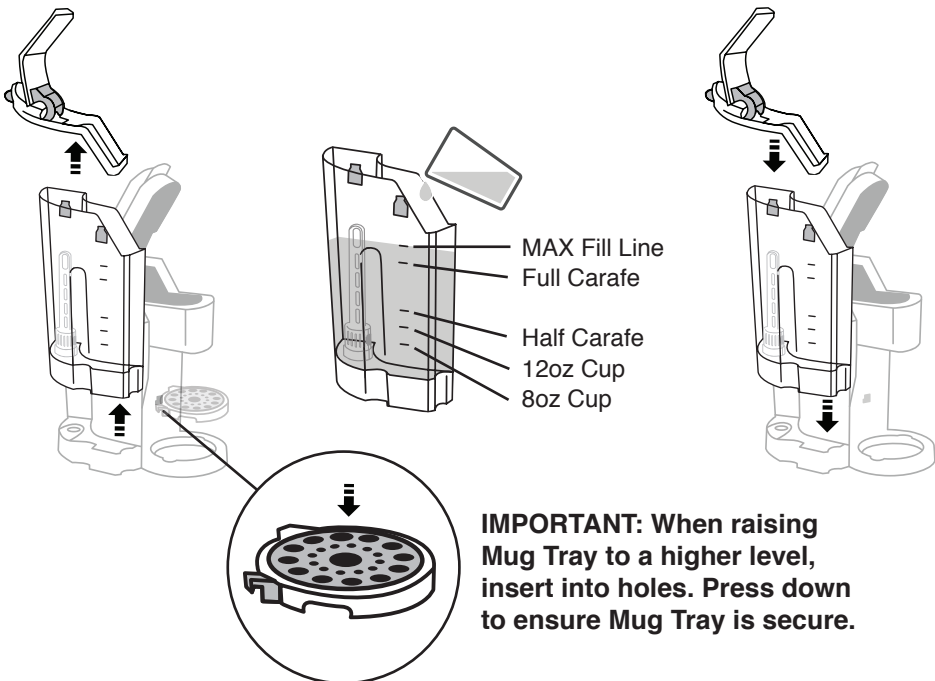

ASSEMBLY FOR INSERTS

With your NuWave BruHub™ 3-in-1 Coffee Maker, you can choose from three different inserts to customize your coffee-drinking experience and preference.

Single Serve Insert

1. Line up dots with each other and place Single Serve Insert into the Insert Chamber.
2. Place pod into Single Serve Insert until connected, indicating needle has gone through.
3. Close down Single Serve Lid.
 - Make sure lid is fully closed.
 - Use Mug Tray on Drip Tray Base and Screen for smaller cups and mugs.
 - Use “8” and “12” sizes for Single Serve Insert.

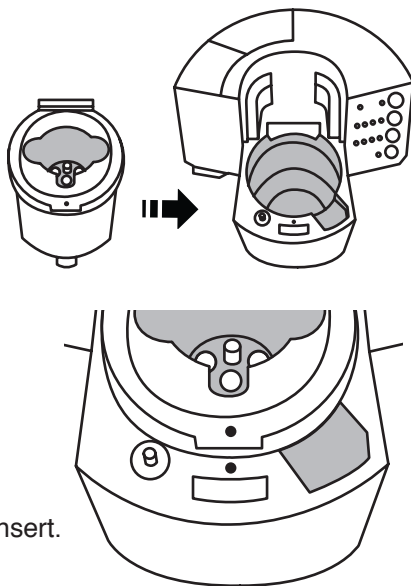

Custom Brew Insert

1. Place Filter Basket inside Custom Brew Insert.
2. Line up dots with each other and place Custom Brew Insert directly down into Insert Chamber.
3. Fill with appropriate amount of coffee grounds.
4. Close lid.
 - Use “8”, “12”, “half carafe” and “carafe” for Custom Brew option.
 - Always use NuWave’s customized carafe when using the Custom Brew Insert.

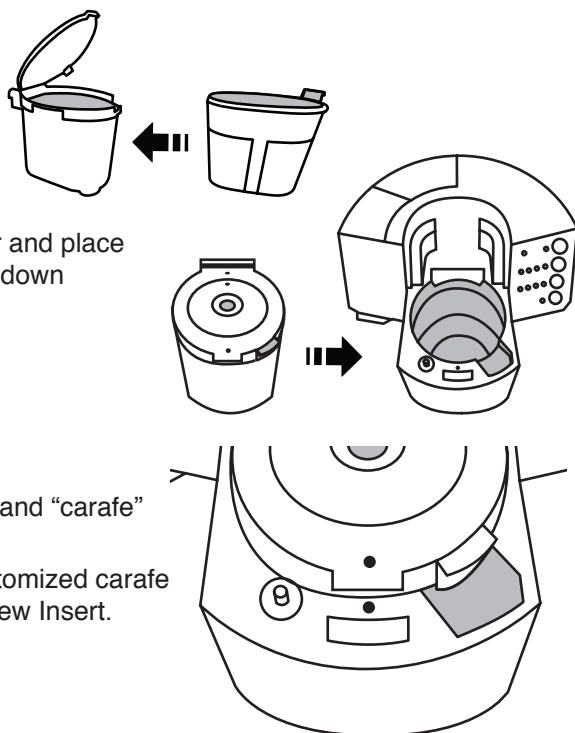

ASSEMBLY FOR INSERTS (CONT.)

Hot Water Insert

Line up dots with each other and place Hot Water Insert directly down into Insert Chamber. Close lid.

- Use Mug Tray on Tray Base for smaller cups and mugs.
- Use “8”, “12”, “half carafe”, and “carafe” for Hot Water Insert.

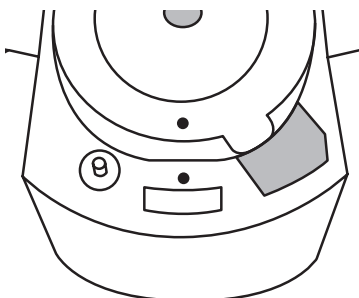
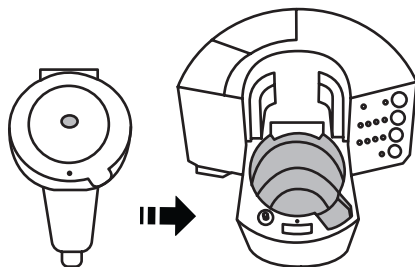

CARAFE ASSEMBLY

1. Place Carafe Lid on top of Carafe Base.

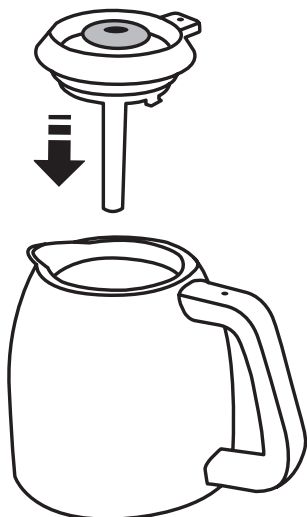

2. Line up dots by turning clockwise to lock into place.

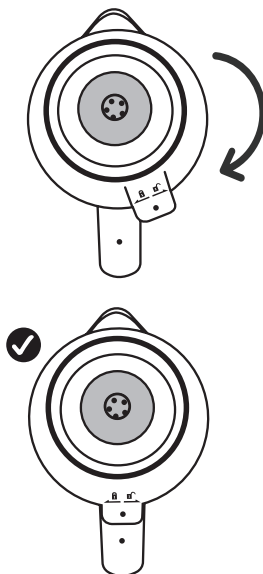

FUNCTIONS FOR THE NUWAVE BRUHUB™

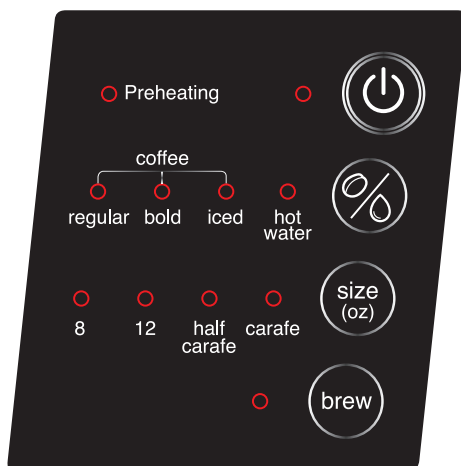

Power Button:



1. Press "Power" button once to turn the unit on. There will be a blue light next to "Power" button to indicate it is on.

- When you press the "Power" button, there will be a red light next to "Preheating". Once it has preheated, the red light will turn off, indicating the water is ready to brew. Once it has preheated, press "Brew".
- Unit will beep when the brew is complete.

2. Press "Power" again to turn the unit off.

Coffee selection function:



This lets you select your favorite beverage with the push of a button.

1. Default is set for "regular".

2. Press the "beverage selection" button once and the blue light next to "bold" will be lit.

3. Press the "beverage selection" button again to change the selection to "iced", "hot water", or back to "regular".

- When "iced" is selected, half of the amount will be dispersed. For example, instead of 8oz, 4oz will be brewed, making the beverage more concentrated.
- Refer to Insert & Beverage Selection Charts for more information.

FUNCTIONS FOR THE NUWAVE BRUHUB™ (CONT.)

size
(oz)

Size selection function:

This lets you choose your amount of beverage you would like brewed.

1. Default is set for “8”, which is 8 ounces.
2. Press the “size selection” button once and the blue light next to “12” will be lit.
3. Press the “size selection” button again to change the selection to “half carafe”, “carafe”, and back to “8”.
 - Refer to Insert & Beverage Selection Charts for more information.

brew

Brew function:

Once you have hit “Power” to turn the unit on, have chosen your selection of beverage, and size, you can now brew.

1. Press the “Brew” button.
 - There will be a red light next to “Preheating”. Once unit has preheated, the red light will turn off, indicating the water is ready to brew and unit will start brewing.
 - Unit will beep when the brew is complete.
 - DO NOT lift lid during brewing cycle. You must wait until brew cycle is finished.
2. To stop the brewing function, press “Brew” button again.

NOTE

- Appliance will not preheat or brew if lid is not fully closed.

INSERT & BEVERAGE SELECTION CHARTS

INSERT SELECTION:

	8oz	12oz	1/2 Carafe 21oz	Full Carafe 42oz
 Single Serve Insert	X	X		
 * Custom Brew Insert	X	X	X	X
 Hot Water Insert	X	X	X	X

* You must use carafe with this insert.

BEVERAGE SELECTION:

Scooper holds 8 grams of coffee grounds when leveled.

Size	Scoops
8oz cup	1 to 2 scoops
12oz cup	2 to 3 scoops
Half Carafe (21oz)	3 to 4 scoops
Full Carafe (42oz)	4 to 5 scoops

* Adjust strength of coffee by using more or less grounds.

CLEANING AND MAINTENANCE

To clean Hot Water Insert, pull up Hot Water Cap to separate and clean insides of both parts.

- Hot Water Insert and Hot Water Cap are dishwasher safe, top rack only.
- Hot Water Cap snaps back on after it's cleaned.

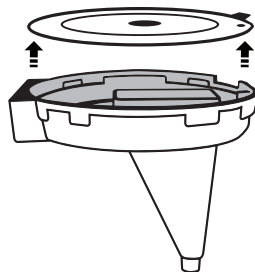

For Custom Brew Insert, lift up Custom Brew Lid to clean inside. Remove Custom Brew Insert Cap.

- Press in the tabs to remove Custom Brew Cap from Custom Brew Lid.
- Custom Brew Cap is dishwasher safe, top rack only.
- Remove Filter Basket to clean individually.

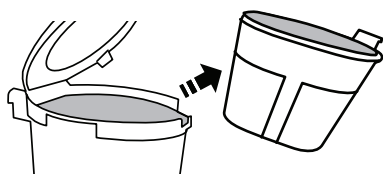
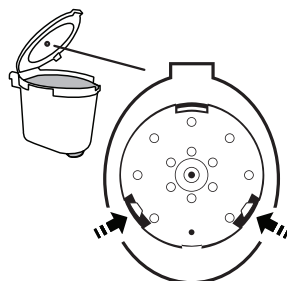

- After cleaning, place inner Custom Brew Cap back in lid by lining up the red arrows and pushing down on the lid until you hear a snap.
- Custom Brew Insert is dishwasher safe, top rack only.

 **Tip:** Cleaning Custom Brew Insert after each use is recommended.

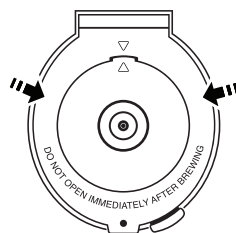

For Single Serve Insert, remove insert and flip the top of lid to clean inside.

- Single Serve Insert is dishwasher safe, top rack only.
- Insert can be hand-washed with running hot water.
- Sharp needle is located in Single Serve Insert. Use caution when cleaning.

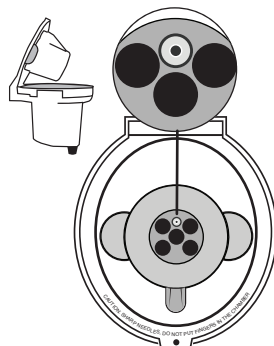

CLEANING AND MAINTENANCE (CONT.)

Cleaning needle under Lid:

The needle is located under the Lid.
To clean needle, use a thin piece of metal or metal wire brush to free the part and area with any blockage.

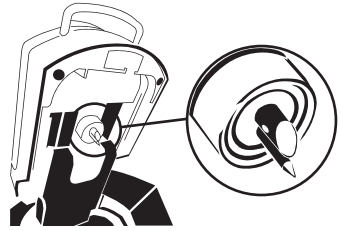

The Mug Tray is detachable and can be removed and cleaned. The two layers can be separated.

- The Mug Tray is dishwasher safe, top rack only.

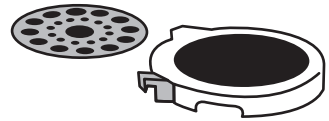

The Drip Tray Base is detachable and can be removed and cleaned.

- The base is dishwasher safe, top rack only.

*Parts should be cleaned in dishwasher set to a low-temperature-energy cycle.

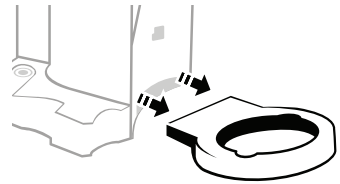

Cleaning the Water Tank and Lid:

To clean the Water Tank, hand-wash only.

- Do not put Water Tank in the dishwasher.

To clean the Water Tank Lid, hand-wash or wipe clean with a damp cloth.

- Lid is dishwasher safe, top rack only.

The Water Tank for the BruHub should be periodically cleaned.

1. Put 1 tablespoon of white vinegar and 2 cups of water in Water Tank.
2. Choose “12” selection, “hot water” and press “Brew”.
3. Once complete, add fresh water and repeat steps.
4. Hand-wash the Water Tank with a damp, soapy, soft cloth, and rinse thoroughly.
5. Let the Water Tank air-dry before returning it back to the Base.

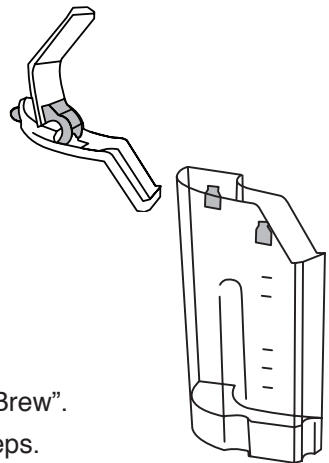

CLEANING AND MAINTENANCE (CONT.)

Cleaning Carafe:

To clean the Carafe, use warm soapy water and rinse thoroughly. Use a soft foam brush with a long handle to reach the bottom.

- The Carafe Lid is removable and is dishwasher safe, top rack only.



External Cleaning

To clean the exterior of your coffee maker, wipe with a damp, soapy, soft cloth.

Descaling

Scale is a buildup that can occur over time after many uses of your appliance. Descaling should be performed every few months to keep your BrewHub working effectively and efficiently. Parts that come into contact with water during the brewing process can have a calcium buildup. Also, the heating element may have deposits that need to be removed.

To descale, use the carafe, fresh water, a safe descaling solution, and perform task near a sink.

1. Turn unit "OFF".
2. Take out Removable Water Tank from unit and empty.
3. Pour descaling solution into the Removable Water Tank.
4. Pour fresh water into the Water Tank.
5. Place Water Tank back into the appliance.
6. Turn unit "On".
7. Place carafe on tray.
8. Hit "Brew" and use largest amount of size for the cycle.
9. When finished, pour all liquid contents into sink.
10. Turn unit "Off".
11. Remove Water Tank and rinse the tank in the sink thoroughly.
12. Remove any excess liquid solution on the Lid above the Water Tank, detachable Drip Tray Base, and other areas.
13. Place Water Tank back into unit and fill with fresh water near the Max Fill Line.
14. Run the largest brew size on the unit.
15. Run multiple brew cycles on the unit.
 - You may need to fill Water Tank more than once during final rinsing process.
16. Turn off appliance and unplug.
17. If there is any descaling solution left over in Water Tank, repeat steps 11-16.

TROUBLESHOOTING

When unit is powered on and no water is in the unit:

- Unit will beep, and within 15 seconds it will shut off.
- If you press “Brew” and there is no water, a continuous beep will sound for up to 15 seconds until you add water.
- If you do not add water within 15 seconds of the continuous beeping, the unit will shut off, and beeping will stop.

If unit is in the middle of brewing and there is not enough water:

- A continuous beep will sound for up to 15 seconds until you add more water.
- If you do not add water after 15 seconds of the continuous beeping, the unit will shut off.

If unit shuts off and you power up the unit again with no water.

- Unit will beep, and within 15 seconds it will shut off.
- If you press “Brew” and there is no water, a continuous beep will sound for up to 15 seconds until you add water.
- If you do not add water within 15 seconds of the continuous beeping, the unit will shut off, and beeping will stop.
- Press “Brew” after the 15 seconds have passed.

Consistent beeping:

- Need to make sure enough water is in the Water Tank.
- The Water Tank has been removed from coffee maker.

Not brewing right away:

- Appliance needs to preheat.
- Needs appropriate amount of water.
- Unit may have automatically shut off. Simply press “Power” to turn back on.

In use unit not preheating or brewing:

- Check to see if the lid is open. Close the lid. Appliance will not preheat or brew if lid is not closed.

TROUBLESHOOTING (CONT.)

Coffee grounds are going into the brewed coffee:

- Do not overfill the filter (do not exceed the MAX line in the filter).
- Recommended to use “drip” coffee grounds or “coarse” grounds when using the Filter Basket.

Coffee maker Filter Basket clogs during brewing process:

- Recommended to use “drip” coffee grounds or “coarse” grounds when using the Filter Basket.



WARNING

Please immediately unplug and contact Customer Service Department if you experience other problems.

1-877-689-2838 or help@nuwavenow.com

LIMITED WARRANTY

The BruHub 3-in-1 Coffee Maker

THE MANUFACTURER WARRANTIES

The NuWave BruHub™ 3-in-1 Coffee Maker, including the BruHub™ Base, the Water Tank Lid, the Water Tank, the Drip Tray Base, the Mug Tray, the Screen, the Charcoal Filter Holder, the Plastic Thermal Carafe, the Hot Water Insert, the Single Serve Insert, and the Custom Brew Insert with Filter Basket are to be free from manufacturer defects. All electrical components are warranted, for 1 year from the date of purchase, under normal household use, and when operated in accordance with the Manufacturer's written instructions.

The Manufacturer will provide the necessary parts and labor to repair any part of the NuWave BruHub™ 3-in-1 Coffee Maker at NuWave, LLC Service Department. After the expiration of the warranty, the cost of the labor and parts will be the responsibility of the owner.

THE WARRANTY DOES NOT COVER

The Limited Warranty is voided if repairs are made by an unauthorized dealer and/or the serial number data plate is removed and/or defaced. Normal deterioration of finish due to use or exposure is not covered by this Warranty. This Limited Warranty does not cover failure, damages or inadequate performance due to accident, acts of God (such as lightning), fluctuations in electric power, alterations, abuse, misuse, misapplications, corrosive-type atmospheres, improper installation, failure to operate in accordance with the Manufacturer's written instructions, abnormal use or commercial use. NuWave, LLC reserves the right to void the Limited Warranty, where allowable by law, for products purchased from an unauthorized dealer.

TO OBTAIN SERVICE

The owner shall have the obligation and responsibility to: Pay for all services and parts not covered by the warranty; prepay the freight to and from Service Department for any part or system returned under this warranty; and carefully package the product using adequate padding material to prevent damage in transit. The original container is ideal for this purpose. Include in the package the owner's name, address, daytime telephone number, a detailed description of the problem, and your "RGA number." Call 1-877-689-2838 or email help@nuwavenow.com to obtain the RGA number (Return Goods Authorization number). Provide the cooking system model & serial number and proof of date of purchase (a copy of the receipt) when making claims under this warranty.

MANUFACTURER'S OBLIGATION

The Manufacturer's obligation under this Limited Warranty is limited, to the extent allowable by law, to repairing or replacing any part covered by this Limited Warranty which upon examination is found to be defective under normal use. The Limited Warranty is applicable only within the continental United States and only to the original purchaser of the manufacturer's authorized channels of distribution. THE LIMITED WARRANTY MAY NOT BE ALTERED, VARIED OR EXTENDED EXCEPT BY A WRITTEN INSTRUMENT EXECUTED BY THE MANUFACTURER. THE REMEDY OF REPAIR OR REPLACEMENT AS PROVIDED UNDER THIS LIMITED WARRANTY IS EXCLUSIVE. IN NO EVENT SHALL THE MANUFACTURER BE LIABLE FOR ANY CONSEQUENTIAL OR INCIDENTAL DAMAGES TO ANY PERSON, WHETHER OR NOT OCCASIONED BY NEGLIGENCE OF THE MANUFACTURER, INCLUDING WITHOUT LIMITATION, DAMAGES FOR LOSS OF USE, COSTS OF SUBSTITUTION, PROPERTY DAMAGE, OR OTHER MONEY LOSS.

Some states do not allow the exclusion or limitation of incidental or consequential damages, so the above limitation exclusions may not apply. This Limited Warranty gives specific legal rights, and there may also be other rights which vary from state to state. EXCEPT AS OTHERWISE EXPRESSLY PROVIDED ABOVE, THE MANUFACTURER MAKES NO WARRANTIES EXPRESSED OR IMPLIED ARISING BY LAW OR OTHERWISE, INCLUDING WITHOUT LIMITATION, THE IMPLIED WARRANTIES OF MERCHANTABILITY AND FITNESS FOR A PARTICULAR PURPOSE TO ANY OTHER PERSON. READ YOUR OWNER'S MANUAL. IF YOU STILL HAVE ANY QUESTIONS ABOUT OPERATION OR WARRANTY OF THE PRODUCT, PLEASE CONTACT NUWAVE, LLC.

READ YOUR OWNER'S MANUAL: If you still have any questions about operation or warranty of the product, please contact NuWave, LLC at: 1-877-689-2838 or email help@nuwavenow.com.



NuWave Oven® Pro Plus



**NuWave Nutri-Pot® 6Q
Digital Pressure Cooker**



**NuWave Brio® 6-Qt
Digital Air Fryer**



**Nutri-Master®
Slow Juicer**



**NuWave PIC® Gold
Precision Induction Cooktop**



**DuraIon® Healthy Ceramic
Non-Stick Cookware**



**Flavor-Lockers®
with Vacuum-Seal Technology**

nuwave®

— LIVE WELL FOR LESS —

www.nuwavenow.com

FOR HOUSEHOLD USE ONLY

Model: 45001 120V, 60Hz, 1500 Watts

For patent information please go to: www.nuwavenow.com/legal/patent

Designed & Developed in USA by:

NuWave, LLC

1755 N. Butterfield Rd.

Libertyville, IL 60048, U.S.A.

Customer Service:

1-877-689-2838 • help@nuwavenow.com

Made in China

©2017 NuWave, LLC • All Rights Reserved.

Item No. BM 45001

Rev. 08A