

*get started*

INSTANT POT® **DUO™**

Instant®

# Welcome

This Instant Pot® Duo™ multifunction cooker can help you cook healthy, delicious meals more easily and in less time. We hope you fall in love with Instant Pot cooking, and enjoy it in your kitchen for years to come!

*This guide is for the Instant Pot Duo version 5. For other user manuals, visit [instanthome.com](http://instanthome.com).*

## CONTENTS

What's in the box	2
Using your Duo	4
Initial set up	8
Pressure cook	10
Sauté	16
Slow cook	18
Yogurt making	19
Keep warm	21
Cleaning	22
Learn more	24

## WHAT'S IN THE BOX

### Lid

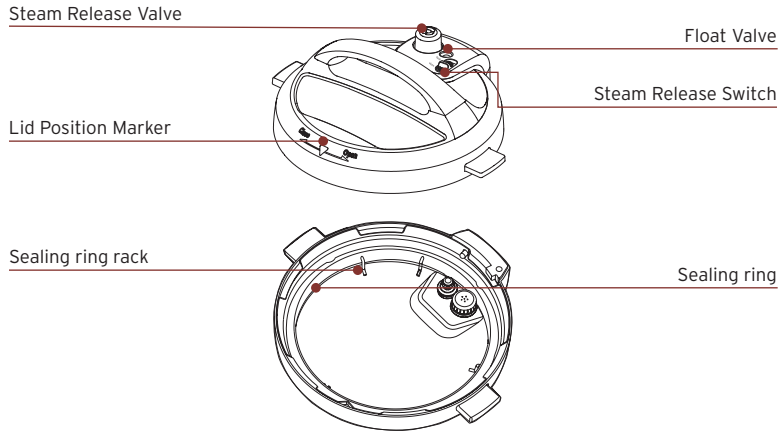

### Stainless Steel Inner Cooking Pot



### Cooker Base

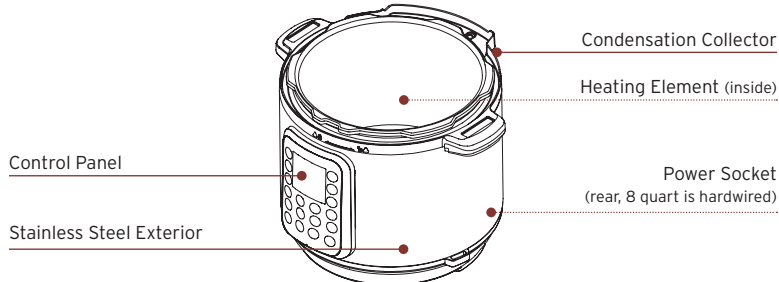

### Parts + accessories

Condensation Collector  
Steam Rack with Handles (Mini steam rack may not have handles)  
*Illustrations are for reference only and may differ from the actual product.*

### Remember to recycle!

We designed this packaging with sustainability in mind. Please recycle everything that can be recycled where you live.

## USING YOUR DUO

### Control panel

We've designed the control panel to be simple to use and easy to read.

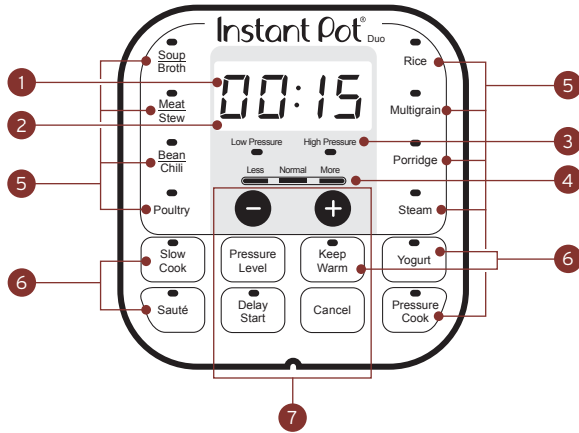

1. Time
  - Cooking time
  - Delay Start time
  - Keep Warm time
2. Status Messages
3. Pressure
  - Low or High
4. Time/temperature options
  - Pressure cooking: 3 preset time options
  - Non-Pressure cooking: 3 temperature levels
5. Pressure Cooking Smart Programs
  - Light shows the active Smart Program
6. Non-Pressure Cooking Smart Programs
  - Light shows the active Smart Program
7. Smart Program Settings
  - Choose Pressure Level
  - Keep Warm On/Off
  - Delay Start On/Off
  - Cancel

### Status messages

The control panel shows information you need to know when using your Instant Pot Duo.

OFF	Standby mode
On	Preheat mode
Lid	Lid not properly secured or missing
05:20	Time <ul style="list-style-type: none"> <li>• Smart Program: cooking time remaining</li> <li>• Delay Start: time until Smart Program starts</li> <li>• Keep Warm: time food has been warming</li> </ul>
Auto	Rice Smart Program is running
boil	Yogurt Smart Program is in pasteurizing cycle
Hot	Sauté Smart Program is ready to add food
End	Smart Program ended (Keep Warm is off)
Food burn	Overheating: see Troubleshooting
E*	Error: see Troubleshooting

## Using the lid

You'll use the pressure cooking lid for all cooking programs that comes with the unit. Always use the pressure cooking lid that came with this Instant Pot Duo cooker base.

### Open the Lid

1. Turn the lid handle to align the arrow symbol on the lid with the unlock symbol on the cooker base.
2. Lift the lid up and off the cooker base.

*You can insert the handle into the cooking base vertically for easy storage.*

### Close the Lid

3. Align the arrow symbol on the lid with the unlock symbol on the cooker base and lower the lid onto the track.
4. Turn the lid until the arrow symbol on the lid aligns with the lock symbol on the cooker base.

## Turning the sound On/Off

### Turn sound on

When in Standby mode, press and hold **+** button until display shows **S On**.

### Turn sound off

When in Standby mode, press and hold **-** button until display shows **SOFF**.

*Audible safety alerts (beeps) cannot be turned off.*

## Delay the start of cooking

You can set a Delay Start timer for a minimum of 10 minutes or a maximum of 24 hours.

1. Select a Smart Program, adjust the settings as you want, then press **Delay Start**.

*Once Delay Start has been selected, there is no way to return to the cooking settings. To adjust Smart Program settings, press Cancel and enter new selections.*

2. When the hours field flashes, use the **- / +** buttons to adjust the delay time hours.

3. Press **Delay Start** again to toggle to the minutes field and adjust the delay time minutes.
4. Delay Start begins automatically and the timer counts down.
5. When Delay Start ends, the Smart Program begins, and the display indicates **On**.

*Delay Start is not available with the Sauté or Yogurt Smart Programs.*

## Reset Smart Programs to original settings

### Reset Individual Smart Programs

- With the cooker in Standby mode, press and hold one Smart Program button until the cooker returns to Standby and shows **OFF**.

*The Smart Program's pressure level, cooking time and temperature are restored to the factory default setting.*

### Reset All Smart Programs

- With the cooker in Standby mode, press and hold **Cancel** until the cooker beeps.

*All Smart Program pressure levels, cooking times and temperatures are restored to the factory default setting.*

## INITIAL SET UP

### Clean before use

1. Wash the inner cooking pot with hot water and soap. Rinse and use a soft cloth to dry the outside. Or you can wash the inner cooking pot in the dishwasher.
2. Wipe the heating element inside the cooker base with a soft cloth to ensure there are no stray packaging particles.

### Setting up the condensation collector

The condensation collector sits at the back of the cooker base and accumulates overflow moisture from the condensation rim. It should be installed before cooking, then emptied and rinsed out after each use.

### Remove the condensation collector

- Pull the condensation collector away from the cooker base; do not pull down.

*Note the tabs on the cooker base and the grooves on the condensation collector.*

### Install the condensation collector

- Align the grooves on the condensation collector with the tabs on the back of the cooker base and slide the condensation collector into place.

### Using the Sealing Ring

When the pressure cooking lid is closed, the sealing ring installed on the underside of the lid creates an air-tight seal between the lid and the cooker base.

- The sealing ring must be installed before using the cooker and should be cleaned after each use.
- Install 1 sealing ring at a time; use one for sweet dishes and one for savory.
- Sealing rings stretch over time with normal use. To keep your product safe, replace the sealing ring every 12 to 18 months. Replace sooner if you notice stretching, deformation, or damage.

### Install the Sealing Ring

1. Place the sealing ring over the sealing ring rack and press it into place. Press down firmly to ensure there is no puckering.
2. The sealing ring should be snug and should not fall out when the lid is turned over.

### Remove the Sealing Ring

1. Grip the edge of the sealing ring and pull it out from behind the sealing ring rack.
2. Inspect the rack to ensure it is secured, centered, and an even height all the way around the lid. If the sealing ring rack is deformed, do not try to repair it.

### Plug in cord (3QT and 6QT models)

When you're ready to use your Instant Pot Duo, plug the electrical cord into the power socket on the back of the unit.

*Note: the 8QT model has an electrical cord that is always connected to the unit.*

### Test run

Setting up your new Instant Pot Duo for a test run is a great way to familiarize yourself with how the unit works before you actually cook a meal.

### To perform a test run:

1. Follow the instructions for pressure cooking on page 9 using the Steam Smart Program.
2. Add water (but no food) as shown in 'Using liquid to create steam' on page 10.
3. Set the cooking time to 5 minutes.
4. After the cooking session is done, discard any remaining water.
5. Wash and dry the inner cooking pot.

*Now you're ready to cook a meal in your Instant Pot Duo!*

## PRESSURE COOK

Pressure cooking uses pressurized steam to quickly and evenly cook foods.

### How to pressure cook

#### Prep

Cut, chop, season or marinate your ingredients according to your recipe.

#### Preheat

1. Place the inner cooking pot into the cooker base.
2. Add ingredients to the inner cooking pot.
3. Place the lid on top of the cooker base and lock the lid.

See 'How to lock the lid' below.

4. Select a smart program for cooking by pressing the button on the control panel.

See 'About pressure cooking programs' above.

5. Press the Smart Program again to toggle between time options: **Less, Normal** or **More**.
6. If you want to increase or decrease the cooking time exactly, press **+** or **-**.
7. Press **Pressure Level** to toggle between pressure options: **High** or **Low**.
8. Keep Warm setting is ON by default. Press **Keep Warm** again to turn it off.
9. After 10 seconds, the display shows **On** and the Instant Pot Duo is building pressure.

*It can take 10-15 minutes to reach the pressure setting for cooking. Frozen foods increase the preheating time.*

*The pressure level and time you choose will be the new settings the next time you use that Smart Program.*

#### Cook

1. When the pressure is ready, your Instant Pot Duo will beep once and starts cooking.
2. The cooking timer starts counting down.
3. When the timer reaches 00:00, the cooker will beep 5 times and the cooking stops.

*You can press Cancel to stop a Smart Program at any time.*

#### Release steam

Choose from the steam release method that works for your recipe.

See 'How to release steam' below for full details

### Using liquid to create steam

Pressure cooking requires liquid in the inner cooking pot to produce the steam needed. Depending on the size of your Instant Pot Duo, here are the minimum amounts you'll need:

Instant Pot Size	Minimum Liquid for Pressure Cooking*
3 Quarts / 2.8 Litres	1 cup (8 oz / 250 mL)
6 Quarts / 5.7 Litres	1 1/2 cups (12 oz / 375 mL)
8 Quarts / 7.6 Litres	2 cups (16 oz / 500 mL)

*\*Unless otherwise specified in recipe.*

*Pressure cooking liquids should be water-based, such as broth, stock, soup or juice. If using canned, condensed, or cream-based soup, add water as directed above.*

### How to lock the lid

For pressure cooking, the lid must be securely locked into place to prevent steam from escaping. When you place the lid on the cooker base:

1. Line up [triangle symbol] on lid with [open padlock symbol] on the cooker base.
2. Turn lid clockwise until [triangle symbol] on lid lines up with [triangle symbol] on cooker base.

## How to release steam

Instant Pot Duo can release steam in 2 different ways. Use the one that best fits the type of food you're cooking.

### Natural steam release

Releases steam gradually over time (up to 40 minutes or more) as after cooking stops.

Use for: Foods that can simmer, like stews, chili, pasta, oatmeal, beans and grains.

1. After cooking, leave steam release switch in **Sealing** position until all pressure is released.
2. Float valve drops into lid when all steam is released.
3. After steam release, turn lid counterclockwise and remove the lid.

### Quick steam release

Quickly releases steam after you press the steam release switch.

Use for: Foods that tend to overcook, like vegetables and seafood.

1. After cooking, set steam release switch to **Venting** position and wait for all pressure to release.
2. Float valve drops into lid when all steam is released.
3. After steam release, turn lid counterclockwise and remove the lid.

## ⚠ Pressure Cooking Caution

This appliance uses pressure to cook. Allow the appliance to release all excess pressure and steam before opening the lid. Opening the lid before pressure is released may result in burns, injury and/or property damage. Read more in the Safety, Maintenance and Warranty document.

## Pressure Cooking Smart Programs

These Smart Programs are designed to pressure cook specific types of food. You can adjust the settings as your recipe directs.

### Soup/Broth

<b>Pressure</b>	Low / High		
<b>Setting</b>	Less	Normal	More
<b>Cooking Time</b>	20 minutes (00:20)	35 minutes (00:35)	4 hours (04:00)
<b>Best for</b>	Soup without meat	Soup with meat	Bone broth / High fat content

#### Tip

*The soup/broth remains clear due to a lack of boiling motion.*

*Use **Natural Release** for soups with a higher starch content.*

### Meat/Stew

<b>Pressure</b>	Low / High		
<b>Setting</b>	Less	Normal	More
<b>Cooking Time</b>	20 minutes (00:20)	35 minutes (00:35)	45 minutes (00:45)
<b>Best for</b>	Softer texture	Very soft texture	Fall-off-the-boat texture

#### Tip

*Allow meat to rest for 5-30 minutes after cooking to retain juices.*



## Beans/Chili

<b>Pressure</b>	Low / High		
<b>Setting</b>	Less	Normal	More
<b>Cooking Time</b>	25 minutes (00:25)	30 minutes (00:30)	40 minutes (00:40)
<b>Best for</b>	Firmer texture	Soft Texture	Very soft texture

### Tips

Choose setting based on desired bean texture or adjust the cook time manually.

When cooking beans or legumes, always use **Natural Release** method.

Make sure dry beans are completely submerged in water.

## Poultry

<b>Pressure</b>	Low / High		
<b>Setting</b>	Less	Normal	More
<b>Cooking Time</b>	5 minutes (00:05)	15 minutes (00:15)	30 minutes (00:30)
<b>Best for</b>	Softer texture	Very soft texture	Fall-off-the-boat texture

### Tip

Allow meat to rest for 5-30 minutes depending on size. It will retain cooking juices for tender, succulent meat.

## Rice

<b>Pressure</b>	Low / High		
<b>Setting</b>	Less	Normal	More
<b>Cooking Time (Auto)</b>	8 minutes (00:08)	12 minutes (00:12)	15 minutes (00:15)
<b>Best for</b>	Al-dente / White Rice	Normal texture / White Rice	Softer texture / White Rice

### Tip

The Instant Pot Duo automatically adjusts cooking time depending on volume of rice; display will show Auto. You can adjust cooking time and setting to achieve desired texture.

Use a 10-minute timed steam release for fluffy rice.

## Multigrain

<b>Pressure</b>	Low / High		
<b>Setting</b>	Less	Normal	More
<b>Cooking Time</b>	20 minutes (00:20)	40 minutes (00:40)	1 hour +45 minutes soaking (01:45)
<b>Best for</b>	Al dente / Brown rice	Brown or wild rice	Tough grains or a mixture of grains and beans

### Tip

The More setting will add an additional 45 minutes for soaking grains/beans with 60 minutes of pressure cooking.

## Porridge

<b>Pressure</b>	Low / High		
<b>Setting</b>	Less	Normal	More
<b>Cooking Time</b>	5 minutes (00:05)	20 minutes (00:20)	30 minutes (00:30)
<b>Best for</b>	Oatmeal: steel cut or rolled	Pudding, porridge, or congee	Porridge or congee with a mixture of various grains

### Tips

Adjust cooking time as recipe directs.

Use Natural Steam Release when cooking foods that expand.

## Steam

<b>Pressure</b>	Low / High		
<b>Setting</b>	Less	Normal	More
<b>Cooking Time</b>	3 minutes (00:03)	10 minutes (00:10)	15 minutes (00:15)
<b>Best for</b>	Vegetables	Fish and seafood	Meat

### Tips

Use the provided steam rack to elevate food above cooking liquid.

Use Quick Steam Release to avoid overcooking food.

## SAUTÉ

Use Sauté in place of a frying or saucepan. Sautéing can deepen the flavors of your food, or can simmer, thicken or reduce sauces.

Choose from these settings in the Sauté Smart Program:

Setting	Less 170 F / 77 C	Normal 154 F / 68 C	More 143 F / 62 C
Cooking time	30 minutes (00:30)	30 minutes (00:30)	30 minutes (00:30)
Best for	Simmering, thickening, and reducing liquids	Pan-searing or sautéing	Stir-frying or browning meat

### How to sauté

#### Prep

Cut, chop, season or marinate your ingredients according to your recipe.

#### Preheat

1. Place the inner cooking pot into the cooker base.
2. Press Sauté.
3. Cycle through temperature presets to select **Less**, **Normal**, or **More**.
4. Press - / + to adjust cooking time.
5. After 10 seconds, the cooker beeps 3 times and the Display shows **ON**.

#### Cook

1. When display shows **Hot**, add ingredients.
2. When timer ends, the cooker beeps 10 times and the display shows **End**.
3. Press **Cancel** if you want to finish cooking before timer runs out.

## Deglazing

Deglazing is the process of adding a liquid to a hot pan, releasing all of the delicious, caramelized pieces stuck to the bottom.

1. Remove food from inner pot.
2. Add water, broth, or wine.
3. Use wooden spoon or silicone spatula to loosen food stuck to bottom of the inner cooking pot.

## Sautéing before Pressure or Slow Cooking

Quite often, you'll want to sauté foods to brown them before further cooking them.

1. Sauté ingredients.
2. Press **Cancel**.

*You can deglaze the inner cooking pot now before switching to **Pressure Cook** or **Slow Cook** (see **Deglazing Inner Pot**)*

3. Select from the Smart Program.

## SLOW COOK

Slow Cook lets you make your favorite simmering and stewing recipes – just like grandma used to make. This program does not use pressure to cook food. Make sure steam release is set to **Venting** or use a glass lid with a venting hole.

Choose from these settings in the Slow Cook Smart Program:

Setting	Less	Normal	More
<b>Best for</b>	'Low and Slow' cooking	Medium setting equivalent on traditional slow cookers	High setting equivalent on traditional slow cookers
<b>Cooking Time</b>	8 hours (08:00)	6 hours (06:00)	4 hours (04:00)

### How to slow cook

#### Prep

Cut, chop, season or marinate your ingredients according to your recipe.

#### Cook

1. Place the inner cooking pot into the cooker base.
2. Add ingredients to the inner cooking pot.
3. Place lid on top of the cooker base and lock the lid.
4. Press **Slow Cook**.
5. Cycle through temperature presets to select **Less, Normal, or More**.
6. Press - / + to adjust cooking time.
7. Keep Warm setting is **On** by default. Press **Keep Warm** again to turn it off.
8. After 10 seconds, the display shows **On** and displays timer.

#### Keep Warm

When cooking completes, the display shows **End** if **Keep Warm** is turned off. If not, the timer begins counting from **00:00** up to 10 hours (**10:00**).

## YOGURT MAKING

You can use your Instant Pot Duo to easily make delicious, fermented dairy and non-dairy yogurt.

Choose from these settings in the Yogurt Smart Program:

Setting	Less	Normal	More
<b>Cooking Time</b>	24 hours (24:00)	8 hours* (08:00)	Not adjustable
<b>Best for</b>	For lower temperature fermentation or Jiu Niang, a sweet, fermented rice dessert	Use for fermenting milk	Use for pasteurizing milk

\* You can adjust time from 30 to 99 minutes.

### How to make yogurt

#### Pasteurizing Milk

1. Insert inner pot into the cooker base.
2. Add unpasteurized milk to the inner pot.
3. Place and close lid.
4. Press **Yogurt**.
5. Press **Yogurt** again to cycle through **Less, Normal, More**.
6. After 10 seconds, display shows **boiL**.
7. When pasteurization finishes, display shows **End**.

*Note: Milk must reach a minimum of 161°F / 72°C for pasteurization to occur.*

#### Adding Culture/Starter

1. Allow pasteurized milk to cool to 43°C / 110°F.
2. Add a starter culture to the milk according to package instructions.  
*If using plain yogurt as a starter, ensure that it contains an active culture. Mix in 2 tbsp (30 mL) of yogurt per 1 gallon (3.7 L) of milk or follow a trusted recipe.*
3. Place and close lid.

## Ferment

1. Press **Yogurt**.
2. Cycle to Normal by pressing **Yogurt** again; display shows 8 hours (08:00).
3. Use **- / +** buttons to adjust the fermentation time if needed.
4. After 10 seconds the cooker begins heating; display shows timer counting up to set time from 00:00.
5. When fermentation completes, the cooker beeps and display shows **End**.  
*A longer fermentation period will produce tangier yogurt.*
6. Allow yogurt to cool.
7. Place in fridge for 12-24 hours to develop flavors.

## How much to make?

Instant Pot Size	Minimum Milk Volume	Maximum Milk Volume
3 Quarts / 2.8 Liters	2 Cups (16 oz / 500 mL)	2 Quarts (64 oz / 1.9 L)
6 Quarts / 5.7 Liters	4 Cups (32 oz / 1000 mL)	4 Quarts (128 oz / 3.8 L)
8 Quarts / 7.6 Liters	6 Cups (48 oz / 1500 mL)	6 Quarts (192 oz / 5.7 L)

## KEEP WARM

The Keep Warm setting turns on automatically after cooking on all Smart Programs except Sauté and Yogurt. You can also use Keep Warm to reheat food.

### Keep warm after cooking

1. When automatic warming begins, the timer shows the time passed, up to 10 hours.
2. To turn automatic warming off (either during cooking or during automatic warming), press **Keep Warm** and the light above the button turns off.

### Reheat and keep warm

1. When in Standby mode, press **Keep Warm**.
2. Press again to cycle through **Less**, **Normal** and **More** temperature levels.
3. Press the **- / +** buttons to set a timer for up to 10 hours.

## CLEANING

Clean your Instant Pot Duo after each use. Always unplug the unit and let all parts cool to room temperature before cleaning. Before use or storing, make sure all surfaces are dry.

Part	Cleaning instructions
Accessories <ul style="list-style-type: none"> <li>• Steam Rack</li> <li>• Condensation Collector</li> </ul>	<ul style="list-style-type: none"> <li>• Wash after each use.</li> <li>• Hand wash with hot water and mild dish soap or wash in dishwasher, top rack.</li> <li>• Never use harsh chemical detergents, powders or scouring pads on accessories.</li> <li>• Empty and rinse condensation collector after each use.</li> </ul>
Lid and Parts <ul style="list-style-type: none"> <li>• Anti-Block Shield</li> <li>• Sealing Ring</li> <li>• Steam Release Valve</li> <li>• Float Valve</li> <li>• Silicone Cap</li> </ul>	<ul style="list-style-type: none"> <li>• Hand wash with hot water and mild dish soap or wash in dishwasher, top rack.</li> <li>• Remove all small parts from lid before washing.</li> <li>• With steam release valve and anti-block shield removed, clean interior of steam release pipe to prevent clogging.</li> <li>• To drain water from the lid after dishwashing, grasp the lid handle and hold the lid vertically over a sink, then turn it all the way around.</li> <li>• After cleaning, store the lid upside down on the cooker base.</li> <li>• Store sealing rings in a well-ventilated area to disperse odor.</li> <li>• To eliminate odors from sealing ring, add 1 cup (8 oz / 250 mL) water and 1 cup (8 oz / 250 mL) white vinegar to inner cooking pot, and run Pressure Cook for 5-10 minutes, then use Quick Steam Release.</li> </ul>
Inner Cooking Pot	<ul style="list-style-type: none"> <li>• Wash after each use.</li> <li>• Hand wash with hot water and mild dish soap or wash in dishwasher.</li> <li>• Hard water stains may need a vinegar-dampened sponge and scrubbing to remove.</li> <li>• For tough or burned food residue, soak in hot water for a few hours before cleaning.</li> <li>• Dry all exterior surfaces before placing in cooker base.</li> </ul>

Part	Cleaning instructions
Power cord	<ul style="list-style-type: none"> <li>• Use a barely-damp cloth to wipe any particles off cord.</li> </ul>
Cooker base	<ul style="list-style-type: none"> <li>• Wipe the inside of the cooker base as well as the condensation rim with a barely-damp cloth, and allow to air dry.</li> <li>• Clean the outside of the cooker base and the control panel with a soft, barely-damp cloth or sponge.</li> </ul>

*Some discoloration may occur after machine washing, but this will not affect the cooker's safety or performance.*

### In the manual

For full details about removing lid parts for cleaning, read the User Manual, available at [instanthome.com](http://instanthome.com).

## LEARN MORE

There's a whole world of Instant Air Fryer information and help just waiting for you. Here are some of the most helpful resources.

### Get the full User Manual

[Instanthome.com](https://www.instanthome.com)

### Register your product

[Instanthome.com/register](https://www.instanthome.com/register)

### Contact Consumer Care

[Instanthome.com](https://www.instanthome.com)

[support@instanthome.com](mailto:support@instanthome.com)

### Instant Recipe App with 1000+ recipes

[Instanthome.com](https://www.instanthome.com)

iOS and Android app stores

### Cooking charts and more recipes

[instanthome.com](https://www.instanthome.com)

### How-to videos, tips and more

[Instanthome.com](https://www.instanthome.com)

### Replacement parts and accessories

[Instanthome.com](https://www.instanthome.com)

### Join the community



## Product specifications

Model	Volume	Wattage	Power	Weight	Dimensions
Duo Mini v5	3 Quart 2.8 Litres	700 watts	120V/ 60 Hz	3.9 kg 8.6 lbs.	in: 11.4 L x 10 W x 11.2 H cm: 29 L x 25.5 W x 28.5 H
Duo 60 v5	6 Quart 5.7 Litres	1000 watts	120V/ 60 Hz	5.35 kg 11.8 lbs.	in: 13.4 L x 12.2 W x 12.5 H cm: 34 L x 31 W x 31.7 H
Duo 80 v5	8 Quart 7.6 Litres	1200 watts	120V/ 60 Hz	7.16 kg 15.79 lbs.	in: 14.8 L x 13.3 W x 14.2 H cm: 37.6 L x 33.8 W x 36.1 H

Instant Brands Inc.  
495 March Road, Suite 200  
Kanata, Ontario, K2K 3G1 Canada

**[instanthome.com](https://www.instanthome.com)**

© 2021 Instant Brands Inc  
110-0043-01-0301