

# PRESTO®

## Pizzazz® Plus

*rotating pizza oven*

The fast and easy way to bake fresh and frozen pizza.  
Great for convenience foods too!

- Prepares frozen, precooked chicken wings and nuggets, breaded jalapeño peppers, cheese nuggets, fish fillets, egg rolls and more. Also makes quesadillas and grilled sandwiches.
- Bakes your favorite pizza extra delicious. Fresh or frozen, thin or rising crust.

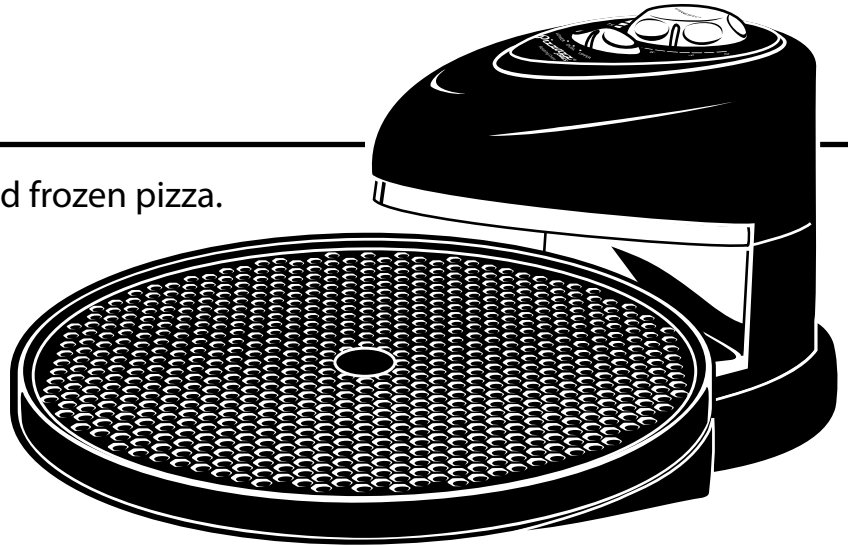

Estas instrucciones también están disponibles en español.

Para obtener una copia impresa:

- Descargue en formato PDF en [www.GoPresto.com/espanol](http://www.GoPresto.com/espanol).
- Envíe un correo electrónico a [contact@GoPresto.com](mailto:contact@GoPresto.com).
- Llame al 1-800-877-0441, oprima 2 y deje un mensaje.



Visit [www.GoPresto.com](http://www.GoPresto.com)

## INSTRUCTIONS

©2019 National Presto Industries, Inc.

Form 4063-002A

This is a  Listed appliance. The following important safeguards are recommended by most portable appliance manufacturers.

### IMPORTANT SAFEGUARDS

To reduce the risk of personal injury or property damage when using electrical appliances, basic safety precautions should always be followed, including the following:

1. Read all instructions.
2. Do not touch hot surfaces.
3. To protect against electrical shock, do not immerse the rotating oven, except the removable baking pan, in water or other liquid.
4. Close supervision is necessary when any appliance is used by or near children.
5. Do not leave unit unattended.
6. Unplug from outlet after using and before cleaning.
7. Do not operate any appliance with a damaged cord or plug or in the event the appliance malfunctions or has been damaged in any manner. Return the appliance to the Presto Factory Service Department for examination, repair, or electrical or mechanical adjustment.
8. The use of accessory attachments not recommended or sold by the appliance manufacturer may cause fire, electric shock, or injury. Use only genuine Presto® accessory attachments and replacement parts.
9. Do not use outdoors.
10. Do not let cord hang over edge of table or counter or touch hot surfaces.
11. Do not place on or near a hot gas or electric burner or in a heated oven.
12. Do not operate rotating oven near flammable objects or place below a paper towel holder. A fire may occur if rotating oven is covered by or touching flammable materials, including curtains, draperies, walls, and the like, when in operation.
13. Do not clean with metal scouring pads. Pieces can break off the pad and touch electrical parts, creating a risk of electric shock.

14. Use extreme caution when removing hot baking pan.
15. Do not use appliance for other than intended use.

## SAVE THESE INSTRUCTIONS

THIS APPLIANCE IS FOR HOUSEHOLD USE ONLY.

### Important Cord and Plug Information

This appliance has a polarized plug (one blade is wider than the other). To reduce the risk of electric shock, this plug is intended to fit into a polarized outlet only one way. If the plug does not fit fully into the outlet, reverse the plug. If it still does not fit, contact a qualified electrician. Do not attempt to modify the plug in any way.

A short power supply cord is provided to reduce the risk of becoming entangled in or tripping over a longer cord. Extension cords may be used if care is properly exercised in their use. If an extension cord is used, the marked electrical rating of the extension cord should be at least as great as the electrical rating of the appliance. The cord should be arranged so that it will not drape over the countertop or tabletop where it can be pulled on by children or tripped over unintentionally.

Connect the power supply cord to a 120VAC electrical outlet only.

### Getting Acquainted

Your Pizzazz® Plus rotating oven will cook an assortment of frozen convenience foods; it can also be used to bake cookies and cinnamon rolls from refrigerated dough, and prepare quesadillas, grilled sandwiches, and 7- to 12-inch pizzas (frozen, take-and-bake, deli, or homemade). No preheating is required.

The selectable heating elements (LOWER-DUAL-UPPER) let you bake a variety of foods—even cookies, cinnamon rolls, and rising crust pizza, as well as providing you with a way to make foods the way **you** like them. Begin by using the recommended settings in the cooking charts. You will find pizza on page 4 and an array of convenience foods on pages 4 and 5. The pizza chart is also reproduced on the back of the oven for easy reference.

With the open oven design, you can see the precise moment your food is done. You can also change the heat setting and time with ease. Want a browner top, select UPPER; prefer a crispier crust, select LOWER. Need to reheat for a minute or two, select DUAL and reset the timer—if the time is short, turn timer dial beyond the 4 minute mark and then back to the desired time. The oven is fast—to avoid overcooking, never leave unit unattended.

Whenever the unit is plugged in, the motor will turn on and the pan will rotate if positioned correctly. Once the timer is set, the heating elements will turn on. When the time has expired, the timer will ring and the heating elements will shut off. The pan will continue to rotate until either it is removed or the unit is unplugged.

### How To Use

Before using for the first time, become familiar with the Pizzazz® Plus rotating oven (Fig. A). Wash the baking pan in warm, soapy water; rinse and dry thoroughly.

1. Set the rotating oven on a flat, dry countertop away from countertop edge.
2. Position the pan over the lower heating element at an angle so the back inside rim of the pan rests against the back of the curls on the lower element tray (Fig. B). Slowly lower the pan until it is parallel to the counter.

Gently drop the pan in place—it will automatically center itself so that the drive shaft is inserted in the pan's hub. Usually, the pan rotates slightly as it drops into place.

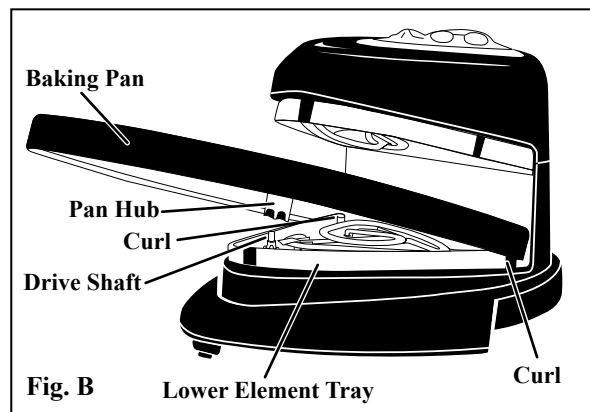
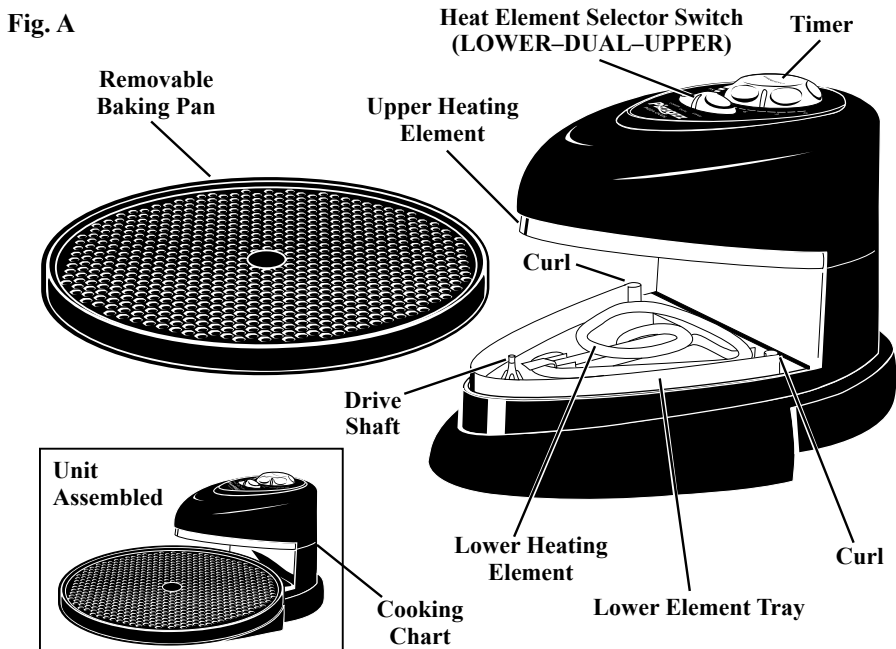

You can tell that it is properly in place by plugging the unit in. The pan will immediately begin to rotate. If it doesn't, reposition the pan using the above instructions.

3. **For making pizza**, remove pizza from box or wrapper and cardboard disk. Center pizza on baking pan. When baking take-out pizza or rising crust pizza, you may use the baking wheel or special baking tray if provided by the pizza manufacturer. Refer to the chart on page 4 for times and settings.

**For making other convenience foods**, remove food from package. Do not use the crisping trays or sleeves on the rotating oven. Distribute food evenly on baking pan. Refer to the charts on pages 4 and 5 for baking instructions for the specific convenience food being prepared.

4. Plug the unit in. The motor will turn on and the baking pan will begin to rotate. **NOTE:** If the baking pan does not rotate, the pan hub is probably not centered over the drive shaft (Fig. B, page 2). Reposition the pan following the instructions in step 2.
5. Slide the heat element selector switch to the appropriate setting (LOWER–DUAL–UPPER).
6. Press the timer dial down and rotate it clockwise to the desired baking time. Refer to the cooking charts on pages 4 and 5, rather than the manufacturer's instructions. Typically, pizzas will cook faster on the Pizzazz® Plus rotating oven than in a conventional oven. **The heating elements will turn on and the food will begin to cook once the timer is set.** Do not preheat the rotating oven.

Be sure to always rotate the timer dial beyond the 4-minute mark then back to the desired time when selecting a setting of four minutes or less.

**NOTE:** When the heating elements are turned on, the metal surrounding the heating elements will expand. You may hear a light humming or vibrating sound, or a slight pop, as the metal expands. This is normal.

7. If the timer goes off and additional baking time is needed, simply reset timer to desired time. To cook 4 minutes or less, rotate the dial beyond "4" and then back to time desired. This will activate the heating elements and timer function. When food appears done, press down on the timer dial and turn it to "0" if it is not at "0" already. The heating elements will turn off when the timer is at the "0" position. **NOTE:** You will hear a clicking sound periodically whenever the unit is plugged in and the timer is at the "0" position. This is normal.
8. While the pan continues to rotate, use hot pads to carefully lift the baking pan off the rotating oven, being careful food does not touch the upper heating element. Set hot baking pan on a heat-resistant surface.
9. **Allow rotating oven to run for 60 to 90 seconds, once baking pan is removed, before unplugging the unit.** Let unit cool before cleaning or storing.
10. Carefully place food on a serving plate or slide pizza onto cardboard disk or pizza tray. Cut and serve. **Do not cut pizza on the baking pan. For best results use nylon, plastic, wooden, or rubber utensils. Do not use metal utensils as they may scratch the nonstick surface.**

## Important Information

- Never leave unit unattended. Pizza ingredients and other foods burn and smoke when overcooked and in extreme situations may even ignite. The amount of rising that occurs on rising crust pizzas varies from pizza to pizza. In rare instances, at the end of the cooking cycle, a rising crust may rise so high that it touches the upper heating element, scorching the crust and overcooking the pizza toppings. This situation can be avoided simply by turning the timer dial to "0" before the overcooking/overrising occurs.
- Do not preheat rotating oven. Preheating an empty baking pan may damage the pan finish.
- Never use the Pizzazz® Plus rotating oven to cook or grill raw fish, poultry, or meats (e.g., bacon, chicken, hamburgers, or steaks) as this may damage the unit.
- Never wrap baking pan or any portion of the rotating oven with aluminum foil.
- Never operate the unit if the pan is not rotating.
- Close adult supervision is necessary whenever using this appliance with children present.
- Never touch the food or any metal parts on the unit while it is operating. They are very hot.
- Always remove baking pan from unit when baking is completed. Operating the rotating oven with an empty baking pan or placing an empty baking pan on the unit before the unit has cooled may result in damage to the baking pan finish.

## Pizza Cooking Chart

The following times are for cooking 9- to 12-inch pizzas. The times are approximate. If cooking 7- or 8-inch pizzas, you may need to reduce the cooking times by 1 to 2 minutes. When the cheese is melted and bubbling, the pizza is done. At the end of the cooking time, if you would like a crispier crust, slide the switch to LOWER; if you would like the toppings more done, slide the switch to UPPER. Then reset the timer by turning it beyond “4” and then back to 1 or 2 minutes and cook until pizza is done to your satisfaction. Do not leave unit unattended.

TYPE OF PIZZA	ELEMENT SETTING	APPROXIMATE COOKING TIME**
<b>FROZEN</b> (9”–12”) Regular Crust	DUAL	12–15 minutes
Rising Crust*	LOWER then DUAL	10–12 minutes LOWER, 10–12 minutes DUAL
Stuffed Crust	LOWER then DUAL	7 minutes LOWER, 12–15 minutes DUAL
Regular Crust, extra topping(s)	DUAL then UPPER	15 minutes DUAL, 3–4 minutes UPPER
<b>FRESH*</b> (9”–12”)	DUAL	11–13 minutes

\*You may use baking wheel or tray, if provided.

\*\*Cooking times will vary depending on household voltage. The higher the voltage, the shorter the cooking time; the lower the voltage, the longer the cooking time.

**NOTE:** When using the Pizzazz® Plus rotating oven, the cooking times will generally be shorter than if cooking the pizza in a conventional oven. **NEVER LEAVE UNIT UNATTENDED.**

## Convenience Food Cooking Chart

The chart below provides suggestions for preparing convenience foods on your Pizzazz® Plus rotating oven. We suggest that you use the suggestions as a starting point and adjust according to individual preference.

**NOTICE:** The Pizzazz® Plus rotating oven is not designed to cook or grill raw fish, poultry, or meats (e.g., bacon, chicken, hamburgers, or steaks) as this may damage the unit.

TYPE OF FOOD	ELEMENT SETTING	APPROXIMATE COOKING TIME**
<b>FROZEN</b>		
Bagel Bites® mini bagels	DUAL	13–14 minutes
Cheese bread and garlic bread slices	DUAL	8–9 minutes
Cheese nuggets/sticks	DUAL	10–11 minutes, turn halfway
Chicken wings, breaded, precooked	DUAL	18–20 minutes, turn halfway
Chicken nuggets, breaded, precooked	DUAL	10–11 minutes
Egg rolls	DUAL	18–19 minutes, turn halfway
Fish fillets, breaded	DUAL	12–13 minutes
HOT POCKETS® brand sandwiches	DUAL	20–22 minutes
Jalapeño peppers, stuffed and breaded	DUAL	14 minutes, turn halfway
Onion rings, breaded	DUAL	12–13 minutes, turn halfway <ul style="list-style-type: none"> <li>Remove baking pan from rotating oven and allow rings to remain on pan for 2 minutes.</li> </ul>

<b>TYPE OF FOOD</b>	<b>ELEMENT SETTING</b>	<b>APPROXIMATE COOKING TIME**</b>
Pizza Rolls® brand pizza snacks	DUAL	10–12 minutes
Potato skins	DUAL	13–14 minutes
Potato patties	DUAL	14–15 minutes, turn halfway
Pretzels	DUAL	6–7 minutes
Taquitos	DUAL	11–12 minutes
<b>REFRIGERATED</b>		
Cookies, chocolate chip	UPPER then DUAL	6 minutes UPPER, 4 minutes DUAL <ul style="list-style-type: none"> <li>• Do not position a cookie in the center of the pan.</li> <li>• Flatten dough slightly.</li> <li>• Remove baking pan from rotating oven and allow cookies to remain on pan for 3 minutes.</li> </ul>
Cinnamon rolls	UPPER then DUAL	3 minutes UPPER, 6–7 minutes DUAL <ul style="list-style-type: none"> <li>• Do not position a roll in the center of the pan.</li> </ul>
<b>OTHER</b>		
Grilled sandwiches	DUAL	8–9 minutes, turn halfway
S'mores (see preparation instructions below)	UPPER	6 minutes or until marshmallow browns
Quesadillas	DUAL	6–10 minutes <ul style="list-style-type: none"> <li>• Cooking time will depend on the type and amount of ingredients.</li> </ul>

\*\*Cooking times will vary depending on household voltage. The higher the voltage, the shorter the cooking time; the lower the voltage, the longer the cooking time.

Bagel Bites is a registered trademark of HJ Heinz Company.

HOT POCKETS is a registered trademark of Société des Produits Nestlé S.A.

Pizza Rolls is a registered trademark of General Mills.

Presto is not affiliated with these companies.

### **To prepare S'mores:**

1. Position baking pan on rotating oven. For each S'more desired, break one graham cracker in half and place one half on baking pan.
2. Place one large marshmallow on graham cracker half.
3. Plug unit in and bake on DUAL setting for 6 minutes, or until marshmallow is browned.
4. Using hot pads, remove baking pan from rotating oven. Immediately top marshmallow with 1 section of a milk chocolate bar. Cover with other graham cracker half.

## Care and Cleaning

1. Always remove baking pan from unit when baking is completed.
2. Allow rotating oven to run for 60 to 90 seconds, then unplug from outlet and allow entire unit to cool completely before cleaning.
3. Wash the nonstick baking pan after each use in warm, sudsy water to remove grease and food residue, rinse, and dry. If necessary, the pan may be cleaned with a nylon mesh pad.
4. Occasionally, wipe the exterior of the rotating oven with a damp cloth and dry thoroughly. Never immerse the rotating oven, except the baking pan, in water or other liquid. Do not wash in the dishwasher.
5. If necessary, the outer rim of the element trays may be cleaned with a nylon mesh pad to remove any food residue. Do not use steel wool scouring pads or abrasive kitchen cleansers on any part of the rotating oven.

## Questions and Answers

***When I plug in my rotating oven and set the timer, the pan does not rotate or only rotates partially and then stops. Why?***

1. The baking pan may not be positioned correctly on the unit. In order for the pan to rotate, the pan hub must be seated over the drive shaft (see Fig. B, page 2). Reposition the pan using the instructions on page 2.
2. The pan may possibly be damaged. Feel around the inside and outside edge of the pan for any dents. In addition, set the pan upside down on a flat surface to see if it sits level. If there are any dents in the pan edge or if the pan wobbles when set upside down on a flat surface, the pan may only rotate partially and then stall. If your pan is damaged, it will need to be replaced in order for the unit to function correctly.

***The baking pan rotates, but my pizza/food does not cook. Why?***

1. You have failed to turn the timer past the 4-minute mark. The timer has a dual function. Once the timer is set, the heating elements will turn on and begin cooking the pizza/food. When the time has expired, the timer will ring and the heating elements will shut off.
2. The heat element selector switch may be between two settings. Slide the switch to the appropriate setting (LOWER–DUAL–UPPER).

***My pizza does not cook evenly. What am I doing wrong?***

1. If the bottom is done and the top isn't or if the top is done and the bottom isn't, you probably have not selected the correct setting for the type of pizza you are cooking. Refer to the cooking chart on page 4 or on the back of the rotating oven for recommended guidelines. Most pizzas should be cooked using the DUAL setting for part of the cooking time.
2. The ingredients on your pizza are not distributed evenly. If that is the case, allow the pizza to cook slightly and then redistribute the ingredients with a fork. This will allow the pizza to cook more evenly.

***How do I get a crispier crust or make my toppings browner?***

Always begin cooking your pizza using the recommended settings in the cooking chart on page 4 or on the back of the rotating oven. Then, at the end of the recommended cooking time if you would like a crispier crust, slide the switch to LOWER; if you would like the toppings more done, slide the switch to UPPER. **Then reset the timer by turning it beyond "4" and then back to 1 or 2 minutes** and cook until pizza is done to your satisfaction. Never leave unit unattended.

***When making cookies and cinnamon rolls, the inside seems doughy or the bottom gets too done. What am I doing wrong?***

You probably have not selected the correct setting. When baking refrigerated cookie dough and cinnamon rolls, bake according to the chart on page 5. Begin using the UPPER setting, then partway through the cooking time, switch to the DUAL setting.

***When I cook rising crust pizza, sometimes the crust seems doughy or sometimes the crust doesn't rise very much. Why?***

Your problem is caused by one of two things:

1. You did not follow the recommended cooking settings. Cook 9- to 12-inch pizzas 10 to 12 minutes first on LOWER and then 10 to 12 minutes on DUAL.
2. The yeast in your pizza crust is no longer fully active. The amount of rising and the consistency of a rising crust are dependent upon the conditions of the yeast. Freshness, freezer temperatures, packaging (vacuum packaged is best), and original dough quality are all important factors. Generally, more consistent results will be secured by nationally branded pizzas since they abide by more rigorous packaging and quality standards than many regional/grocery store pizzas.

Try this recipe with your favorite toppings for a pizza with great homemade taste.

## Homemade Pizza

- |  |   |
|--|---|
| 1 loaf of frozen bread dough, thawed<br><b>OR</b> 1 recipe Basic Pizza Dough<br>(see recipe below) | ½ cup of favorite toppings<br>(see suggestions below) |
| ½ cup commercial pizza sauce   | 1 cup shredded part-skim milk<br>mozzarella cheese    |

Form bread loaf or pizza dough into a ball; place ball in center of baking pan and roll or stretch dough to a 10- to 12-inch circle.\* Lightly prick dough with fork. Spread pizza sauce evenly over dough. Place toppings evenly over sauce; sprinkle with mozzarella cheese. Place loaded baking pan on rotating oven and bake using the DUAL setting for 11 to 13 minutes or until cheese is melted and bubbling. If you prefer a crisp crust and have a large amount of toppings, it may be desirable to use the LOWER setting for 4 to 6 minutes before switching to DUAL for 11 to 13 minutes.

\*To make baking pan more stable for rolling or stretching dough, place a kitchen towel under baking pan.

## Basic Pizza Dough†

- |                                  |                             |
|----------------------------------|-----------------------------|
| Pinch sugar                      | 2½–3 cups all-purpose flour |
| 1 cup warm water (105° to 115°F) | ½ teaspoon salt             |
| 1 package active dry yeast       | 2 tablespoons olive oil     |

Dissolve sugar in water. Sprinkle yeast over water mixture; stir to dissolve. Let proof 5 minutes until bubbly.

Put 2½ cups flour in large bowl. Make a well in the center. Add salt in well. Pour in yeast mixture and olive oil. Stir to form soft dough. Turn dough onto lightly floured surface and knead until smooth and elastic, 5 to 10 minutes, adding flour gradually as needed. Transfer dough to lightly oiled large bowl, rolling dough to coat with oil. Cover with plastic wrap and let rest in a warm spot until doubled in size, about 1 hour.

Punch dough down with fist. Turn dough out onto lightly floured surface and shape into 1 or 2 balls. Cover with a towel and let rest 15 to 20 minutes. Roll or stretch dough to a 12-inch diameter and place on Presto® Pizzazz® Plus baking pan.

†Dough recipe makes 2 thin crusts or 1 thick crust, depending on preference.

### Suggestions for Pizza Toppings:

- |                                     |                           |
|-------------------------------------|---------------------------|
| spicy sausage/onions/black olives   | pepperoni/mushrooms       |
| spicy chicken/yellow and red pepper | ham/sauerkraut            |
| Canadian bacon/pineapple            | spinach/onions/garlic     |
| squash/sun-dried tomatoes           | artichoke hearts/tomatoes |

## Santa Fe Quesadilla

- |  |  |
|--|--|
| 2 burrito-size flour tortillas (9-inch diameter)   | 2 tablespoons prepared chipotle salsa, or preferred type |
| ⅓ cup prepared spicy black bean dip                | ¼ cup fresh or frozen (thawed) corn kernels              |
| ¼ teaspoon ground cumin                            | 1 tablespoon sliced scallions                            |
| 4 ounces cooked chicken, cut in strips or shredded | ½ tablespoon chopped cilantro                            |
| 1 tablespoon taco seasoning                        | ½ cup shredded pepper jack cheese                        |

Place 1 tortilla on baking pan.\* Spread black bean dip evenly over tortilla. Sprinkle with cumin.

In plastic bag, toss chicken with taco seasoning so chicken strips are evenly coated. Remove chicken from bag and mix with salsa in small mixing bowl. Place chicken mixture evenly over bean dip. Sprinkle with corn, scallions, and cilantro. Top with cheese. Place remaining tortilla on top of cheese.

Place loaded baking pan on rotating oven and bake on DUAL setting for 9 to 10 minutes or until tortilla is crisp and browned. Remove from baking pan and cut into wedges.

\*To make baking pan more stable for preparing quesadilla, place a kitchen towel under baking pan.

## Consumer Service Information

If you have any questions regarding the operation of your Presto® appliance or need parts for your appliance, contact us by any of these methods:

- Call 1-800-877-0441 weekdays 8:00 AM to 4:00 PM (Central Time)
- Email us through our website at [www.GoPresto.com/contact](http://www.GoPresto.com/contact)
- Write: National Presto Industries, Inc., Consumer Service Department  
3925 North Hastings Way, Eau Claire, WI 54703-3703

Inquiries will be answered promptly by email, telephone, or letter. When emailing or writing, please include a phone number and a time when you can be reached weekdays if possible.

When contacting the Consumer Service Department, please indicate the model and series numbers for the rotating oven. These numbers can be found on the bottom of the unit. Please record this information:

Model \_\_\_\_\_ Series \_\_\_\_\_ Date Purchased \_\_\_\_\_

The Presto Factory Service Department is equipped to service Presto® appliances and supply genuine Presto® parts. Genuine Presto® replacement parts are manufactured to the same exacting quality standards as Presto® appliances and are engineered specifically to function properly with its appliances. Presto can only guarantee the quality and performance of genuine Presto® parts. “Look-alikes” might not be of the same quality or function in the same manner. To ensure that you are buying genuine Presto® replacement parts, look for the Presto® trademark.

Canton Sales and Storage Company, Presto Factory Service Department  
555 Matthews Drive, Canton, MS 39046-3251

## Product Registration

**IMPORTANT:** Please go online and register this product within ten days of purchase. Proper registration will serve as proof of purchase in the event your original receipt becomes misplaced or lost. Registration will not affect warranty coverage, but it may expedite processing of warranty claims. The additional information requested will help us develop new products that best meet your needs and desires. To register your product, visit [www.GoPresto.com/registration](http://www.GoPresto.com/registration) or simply scan this QR code. If you do not have computer access, call the Consumer Service Department at 1-800-877-0441.



### **Presto® Limited Warranty**

*(Applies only in the United States)*

This quality Presto® appliance is designed and built to provide many years of satisfactory performance under normal household use. Presto pledges to the original owner that should there be any defects in material or workmanship during the first year after purchase, we will repair or replace it at our option. Our pledge does not apply to damage caused by shipping. ***Outside the United States, this limited warranty does not apply.***

To obtain service under the warranty, please call our Consumer Service Department at 1-800-877-0441. If unable to resolve the problem, you will be instructed to send your Presto® appliance to the Presto Factory Service Department for a quality inspection; shipping costs will be your responsibility. When returning an appliance, please include your name, address, phone number, and the date you purchased the appliance as well as a description of the problem you are encountering with the appliance.

We want you to obtain maximum enjoyment from using this Presto® appliance and ask that you read and follow the instructions enclosed. Failure to follow instructions, damage caused by improper replacement parts, abuse, misuse, disassembly, alterations, or neglect will void this pledge. This warranty gives you specific legal rights, and you may also have other rights which vary from state to state. This is Presto's personal pledge to you and is being made in place of all other express warranties.

**National Presto Industries, Inc.**  
Eau Claire, WI 54703-3703

Form 4063-002A