

SereneLife



SLRWMC18
Sports Training Row Machine

Smart Rowing Machine with Digital Computer
Exercise Monitor, Portable Folding Style,
Adjustable Resistance

USER MANUAL

IMPORTANT!

- Please read all instructions carefully before using this product.
- Retain this manual for future reference.
- The specifications of this product may vary slightly from the illustrations and are subject to change without notice.

IMPORTANT SAFETY NOTICE

Note the following precautions before assembling and operating the machine.

1. Read this User's Manual and follow the instruction carefully before using the **Rowing Machine**. Make sure that it is properly assembled and tightened before use.
2. We recommend having two people for assembling this machine.
3. To lubricate all moving parts annually is recommended.
4. Do not wear loose clothing to avoid entangling in any moving parts.
5. Set up and operate the rowing machine on a solid level surface.
6. Always wear shoes when using the machine.
7. Please keep children and pets away from the machine while it is in use.
Do not allow children to play or use the machine. This machine is designed for adults, not children.
8. Please maintain your balance while using the machine.
9. Stop exercise immediately in case of nausea, shortness of breath, faint, headache, pain, tightness in your chest or any discomfort.
10. Do not place fingers or any other objects into the moving parts.
11. Prior to any exercise, consult with your physician first to establish the exercise frequency, time and intensity appropriate for your particular age and condition.
12. Do not grasp the seat to move the Rowing Machine. The seat will move and it may hurt your hand and fingers.
13. The rowing machine should be used by only one person at a time.
14. Maximum user's weight is 100KG.

EXPLODED DIAGRAM

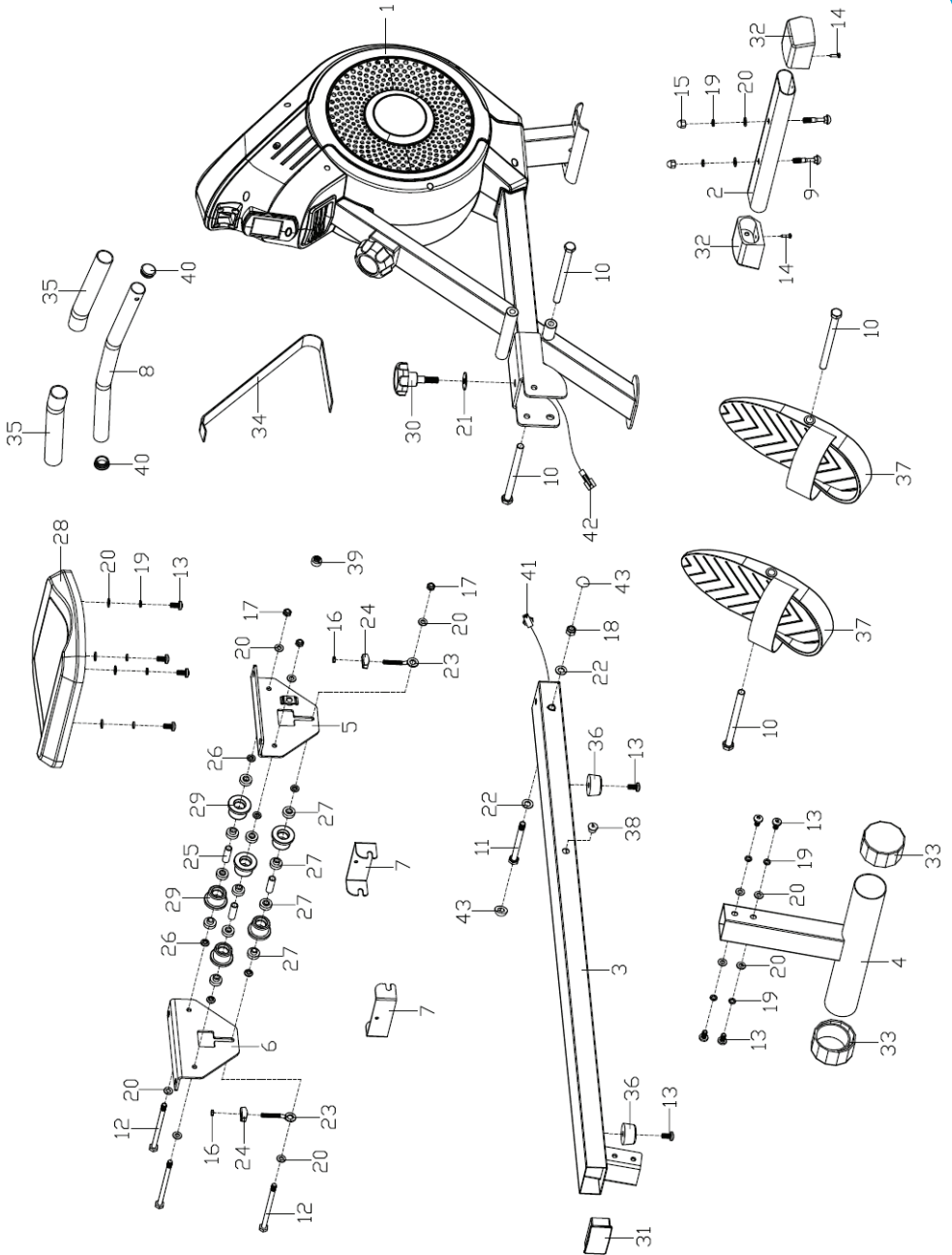

PARTS LIST

NO.	Description	QTY	NO.	Description	QTY
1	Main frame	1	23	Adjustable bolt M6*36	2
2	Front bottom tube	1	24	U-shape washer	2
3	Guide rail	1	25	Spacer $\phi 9 * \phi 12 * 35.8$	3
4	Rear support frame	1	26	Spacer $\phi 13 * \phi 8.2 * 3$	6
5	Right support frame	1	27	Bearing	12
6	Left support frame	1	28	Saddle	1
7	U baffle plate	2	29	PU wheel	6
8	Handlebar	1	30	Bolt	1
9	Square neck bolt M8*L45*120*8	2	31	Square tube plug	1
10	Bolt M12*155*16	4	32	Front end cap	2
11	Hex bolt M10*105	1	33	Rear end cap	2
12	Hex bolt M8*125*L15	3	34	Fabric belt	1
13	Hex socket pan head screw M8*16	10	35	Foam grip	2
14	Cross recessed pan head tapping screws ST4.2*18	2	36	Cushion	2
15	Cap nut M8	2	37	Paddle	2
16	Nylon nut M6	2	38	Plug	1
17	Nylon nut M8	3	39	Round magnet with bracket	1
18	Nylon nut M10	1	40	Round tube plug	2
19	Spring washer D8	10	41	Sensor wire	1
20	Flat washer D8* $\phi 16 * 1.5$	16	42	Extension wire	1
21	Flat washer D10* $\phi 32 * 2$	1	43	Ball cap	2
22	Flat washer D10* $\phi 20 * 1.5$	2			

ASSEMBLY INSTRUCTIONS

STEP 1:

Lock Rear support frame (4) on Guide rail (3) with Hex socket pan head screw (13), Spring washer (19) and Flat washer (20).

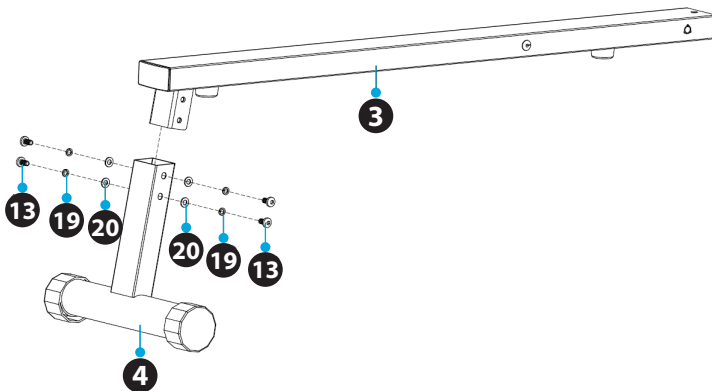

STEP 2:

Take off the cushion (36) and insert the Saddle (28) on Guide rail (3). Then fasten cushion (36) back to Guide rail (3) with Hex socket pan head screw (13).

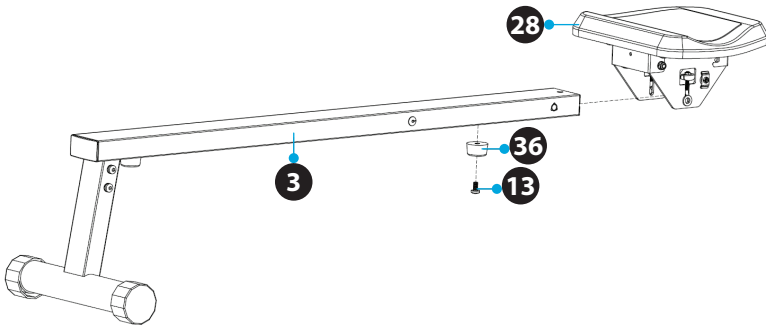

STEP 3:

Assemble Front bottom tube (2) to Main frame (1) with Square neck bolt (9). Flat washer (20), Spring washer (19) and Cap nut (15).

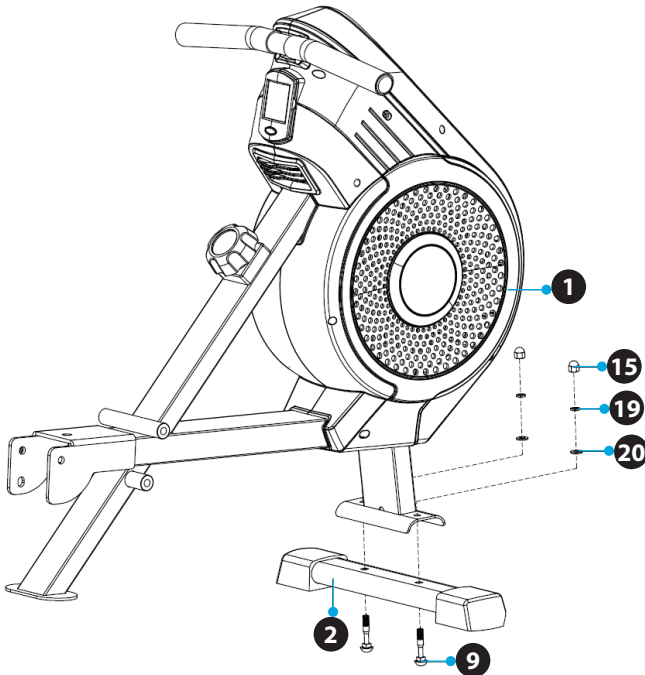

STEP 4:

1. Connect Sensor wire (41) and Extension wire (42) well.
2. Secure Guide rail (3) on Main frame (1) with Hex bolt (11), Flat washer (22), Nylon nut (18), then put on Cap nut (43).
3. Lock Guide rail (3) on Main frame (1) with Bolt (30) and Flat washer (21).

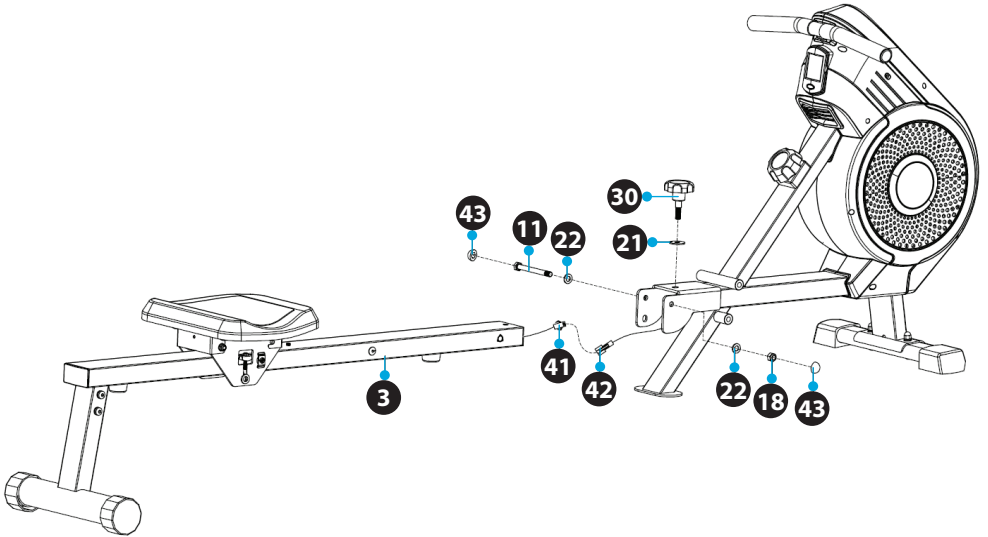

STEP 5:

- Assemble Paddle (37) on Main frame (1) with Bolt (10).

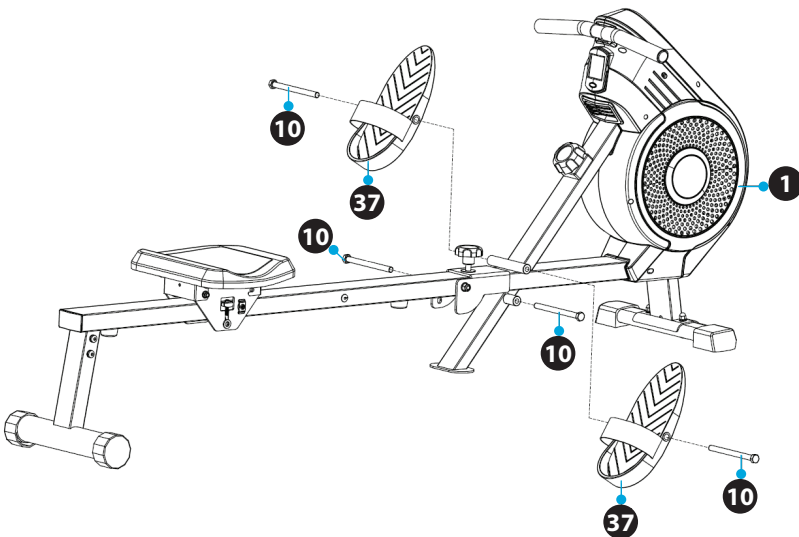

FOLD MACHINE

The Rowing machine could be folded if you do not use it. (Please watch out your hands to avoid injury when folding)

1. Unscrew Bolt (30) , then take off Bolt (30) and Flat washer (21). Lift up Guide rail (3) in arrow direction, as Figure 1 show.
2. Align the hole of Guide rail (3) and Main frame (1), then lock them together with Bolt (30) and Flat washer (21), as Figure 2 show.

Figure 1

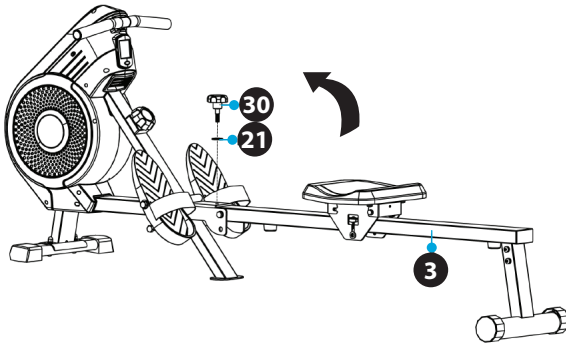
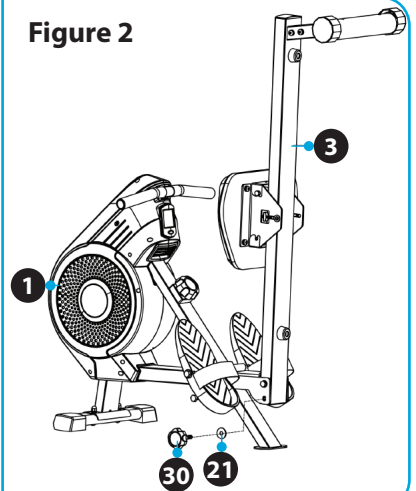

Figure 2



EXERCISE MONITOR

SPECIFICATIONS:

TIME	00:00 - 99:59 MIN:SEC
COUNT	0 - 9999 TIMES
CALORIES	0.0 - 999.9 KCAL
STRIDES/MIN(RPM)	0 - 999 TIMES/MIN
TOT.CNT	0 - 9999 TIMES
DIST	0.00 - 999.9 MI/H

KEY FUNCTION:

MODE/SELECT: To select the function you want. Hold the key for 4 seconds to have all function values reset (total reset).

RESET/CLEAR (if have): To let the value reset.

OPERATION PROCEDURES:

AUTO ON/OFF: The monitor will be automatically shut off if there is no signal coming in for 4 minutes. The monitor will be auto-powered when start exercise or press the key.

FUNTION:

<1>.TIME	Displays the time of the current movement
<2>.COUNT	Displays the current number of movements
<3>.CALORIES	Displays the calories expended during the current exercise
<4>.STRIDES/MIN	Display the steps per minute while exercising.
<5>. TOTAL CNT	Display the steps you have exercised.
<6>. DIST	Displays the current distance traveled

BATTERY: If there is a possibility to see an improper display on the monitor. Please replace the batteries to have a good result. This monitor uses two "AAA" batteries, replace the batteries at the same time.

WARM-UP and COOL-DOWN

A successful exercise program consists of a warm-up, aerobic exercise, and a cool-down. Do the entire program at least two and preferably three times a week, resting for a day between workouts. After several months, you can increase your workouts to four or five times per week.

WARM-UP

The purpose of warming up is to prepare your body for exercise and to minimize injuries. Warm up for two to five minutes before strength-training or aerobic exercising. Perform activities that raise your heart rate and warm the working muscles. Activities may include brisk walking, jogging, jumping jacks, jump rope, and running in place.

STRETCHING

Stretching while your muscles are warm after a proper warm-up and again after your strength or aerobic training session is very important. Muscles stretch more easily at these times because of their elevated temperature, which greatly reduces the risk of injury. Stretches should be held for 15 to 30 seconds. **DO NOT BOUNCE.**

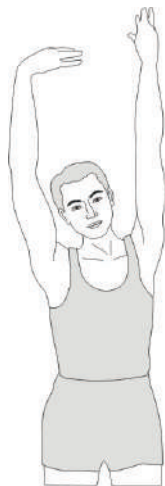

Side Stretch



Toe Touch



Inner Thigh Stretch

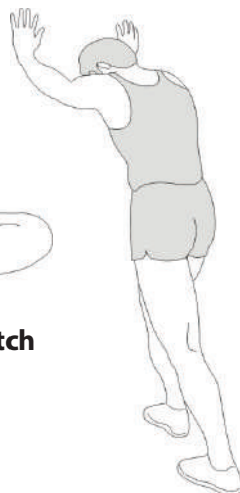

Calf-Achilles Stretch



Hamstring Stretch

Remember always to check with your physician before starting any exercise program.

COOL-DOWN

The purpose of cooling down is to return the body to its normal or near normal, resting state at the end of each exercise session. A proper cool-down slowly lowers your heart rate and allows blood to return to the heart.

SLRWMC18

Sports Training Row Machine

**Smart Rowing Machine with Digital Computer Exercise Monitor,
Portable Folding Style, Adjustable Resistance**

Features:

- Smart Fitness Rowing Machine
- Compact Gym Exercise Rower Style
- For Sports Training, Cardio Fitness, Weight Loss Fat Burning
- Measures Time, Distance, Strides, Calories Burned
- Digital LCD Display Computer Panel
- Adjustable Resistance Rower Level Setting
- Portable Folding Stand-Up Design for Easy Storage
- Quiet, Smooth-Gliding Contour Row Seat
- Comfortable Handlebar Grip and Pedal-Style Footrests
- Rugged Construction with Reinforced Handlebar Pull Cable
- Safety-Certified Reliable & Lab Tested
- Auto Power-Off Battery Saving Function
- Perfect for Indoor Home & Office Gym
- *Some Assembly Required

Technical Specs:

- Rowing Resistance Type: Magnetic
- Adjustable Time Setting: Up to 99 Minutes
- Maximum Rowing Distance Measurement: 999.9 Miles
- Selectable Resistance / Row Intensity: (8) Levels
- Construction Material: Steel Metal Alloy, Engineered ABS
- User Weight Capacity: Up to 220 lbs.
- Battery Operated Computer, Requires (2) x 'AAA' Batteries, Included
- Slide Rail Length, Rowing Distance: 30.7" –inches
- Folded / Collapsed Rower Size (L x W x H): 39.3" x 17.7" x 53.1" -inches
- Total Assembled Rower Size (L x W x H): 77.2" x 16.1" x 29.9" -inches



Questions? Issues?

We are here to help!

Phone: (1) 718-535-1800

Email: support@pyleusa.com



WARNING:

This product can expose you to a chemical or group of chemicals, which may include "**Nickel Carbonate**" which is known in the state of California to cause cancer, birth defects, or other reproductive harm. For more info, go to <https://www.p65warnings.ca.gov/>.



SereneLife