

# SereneLife



## SLEPL9 Compact Ergonomic Elliptical Machine

Mini Exerciser with Adjustable Resistance  
and LCD Monitor with Resistance Bands

***User Manual***

## ▶▶ SAFETY INSTRUCTIONS

**Basic precautions should always be followed, including the following safety instructions when using this equipment:**

**Read all instructions before using this equipment.**

1. Read all the instructions in this manual and do warm up exercises before using this equipment.
2. Before exercise, in order to avoid injuring the muscle, warm-up exercise of every position of the body is necessary. Refer to Warm Up and Cool Down Routine page. After exercise, relaxation of the body is suggested for cool-down.
3. Please make sure all parts are not damaged and fixed well before use.  
This equipment should be placed on a flat surface when using. Using a mat or other covering material on the ground is recommended.
4. Please wear proper clothes and shoes when using this equipment; do not wear clothes that might catch any part of the equipment.
5. Do not attempt any maintenance or adjustments other than those described in this manual. Should any problems arise, discontinue use and consult an Authorized Service Representative.
6. Do not use the equipment outdoors.
7. This equipment is for household use only.
8. Only one person should be on the equipment while in use.
9. Keep children and pets away from the equipment while in use. This machine is designed for adults only. The minimum free space required for safe operation is not less than two meters.
10. If you feel any chest pains, nausea, dizziness, or short of breath, you should stop exercising immediately and consult your physician before continuing.
11. The maximum weight capacity for this product is 120kgs.

### **WARNING:**

**It's best to check with your doctor before you start to exercise. This is especially important for the persons who are over 35 years old or who have pre-existing health problems. Read all instructions before using any fitness equipment.**

**⚠ CAUTION:**

**Read all instructions carefully before operating this product.  
Retain this Owner's Manual for future reference.**

**▶▶▶ HARDWARE PACKING LIST**

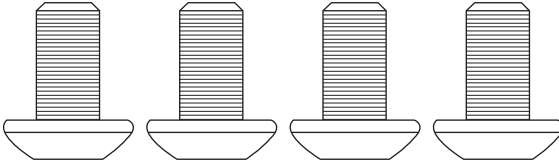

**A. Hex socket bolt M8x16**

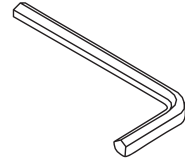

**B. Allen wrench/key**

**▶▶▶ ASSEMBLY INSTRUCTIONS**

Attach the left and right pedal into the corresponding pedal tube (C and D), tighten them with the provided Allen Key.

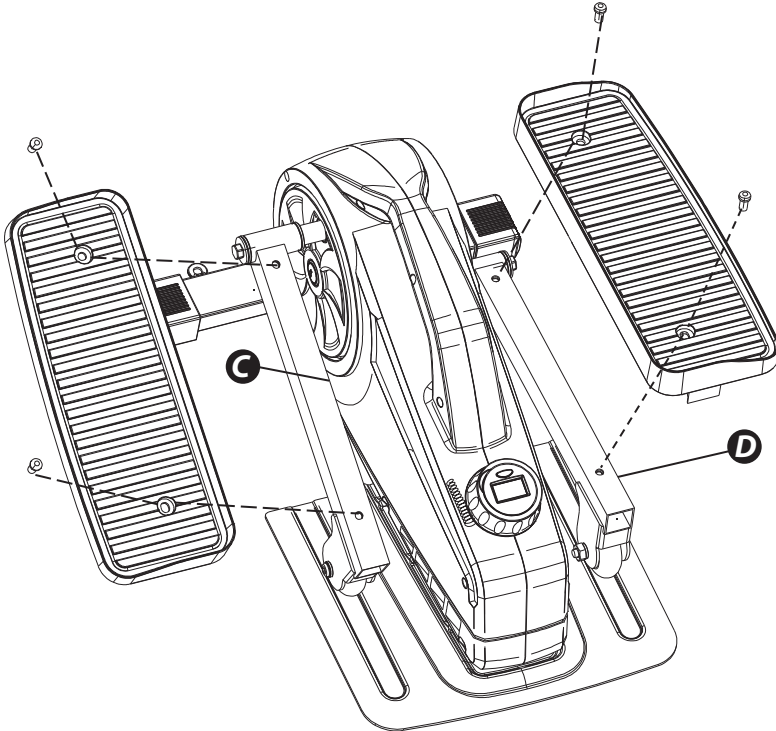

## ▶▶▶ MONITOR FUNCTIONS:



<b>TOTCNT</b>	Gauges the total cycles of your pedal
<b>TMR</b>	Shows amount of the time of workout
<b>CALORIES</b>	Shows calories burnt whilst exercising
<b>CNT</b>	Gauges your pedal cycles
<b>S (SCAN)</b>	Display each function every 6 seconds

**To switch between modes press the button.**

To reset back to zero, press and hold the button for 4 seconds.

Monitor requires 1.5V LR44 battery.

*The readings from the display monitor may vary and are not used only as a guide.*

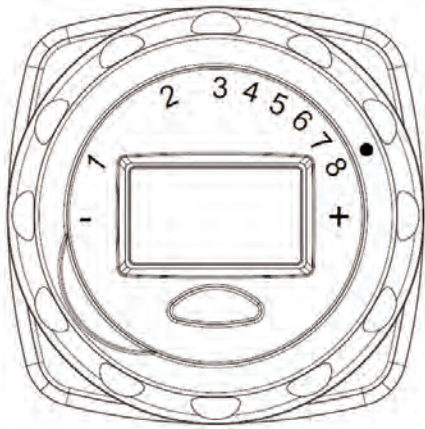

### ▶▶ TENSION ADJUSTMENT:

For tension adjustment, simply use the tension adjustment knob found together with the Computer. To increase tension, turn clockwise (+), to decrease tension, turn anti-clockwise (-).

The maximum tension levels is level 8.  
The minimum tension level is level 1.

### ▶▶ BATTERY REPLACEMENT:

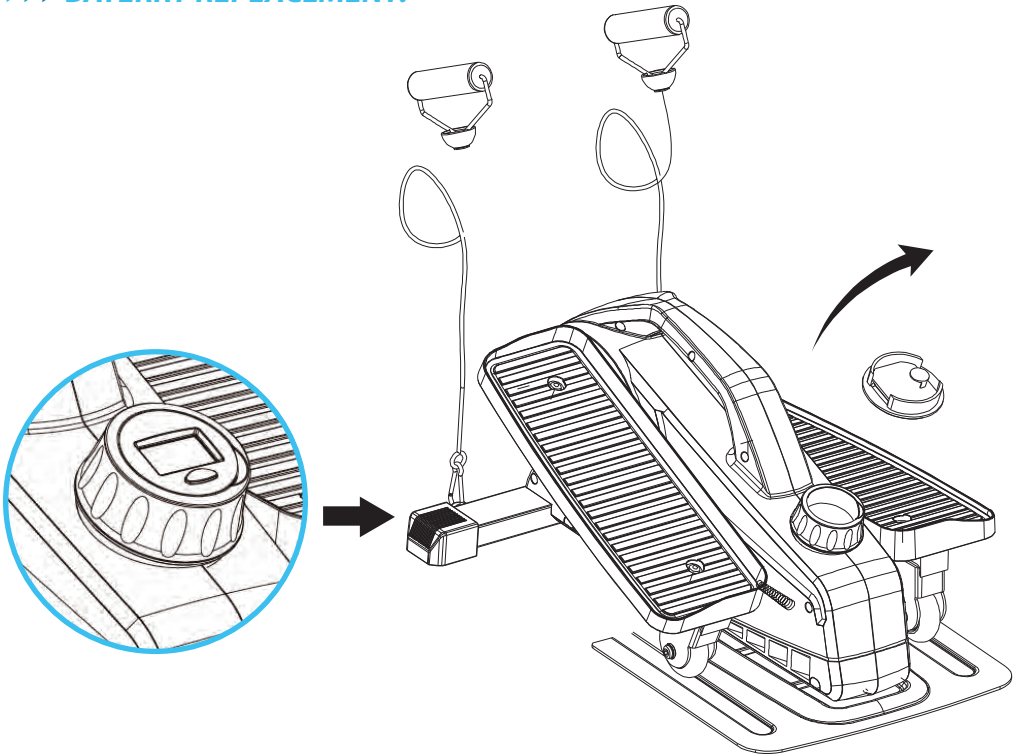

Open the lid of monitor, replace the battery and then cover it back.

## ▶▶▶ Warm Up Exercises

A successful exercise program consists of a warm-up, aerobic exercise, and a cool-down. Do the entire program at least two and preferably three times a week, resting for a day between workouts. After several months, you can increase your workouts to four or five times per week.

Warming up is an important part of your workout, and should begin every session. It prepares your body for more strenuous exercise by heating up and stretching out your muscles, increasing your circulation and pulse rate, and delivering more oxygen to your muscles. At the end of your workout, repeat these exercises to reduce sore muscle problems. We suggest the following warm-up and cool-down exercises:

### Inner Thigh Stretch

Sit with the soles of your feet together with your knees pointing outward. Pull your feet as close into your groin as possible. Gently push your knees towards the floor. Hold for 15 counts.



### Hamstring Stretch

Sit with your right leg extended. Rest the sole of your left foot against your right inner thigh. Stretch toward your toe as far as possible. Hold for 15 counts. Relax and then repeat with left leg extended.

### Head Roll

Rotate your head to the right for one count, feeling the stretch up the left side of your neck. Next, rotate your head back for one count, stretching your chin to the ceiling and letting your mouth open. Rotate your head to the left for one count, and finally, drop your head to your chest for one count.



### Shoulder Lift

Lift your right shoulder up toward your ear for one count. Then lift your left shoulder up for one count as you lower your right shoulder.

## Calf-Achilles Stretch

Lean against a wall with your left leg in front of the right and your arms forward. Keep your right leg straight and the left foot on the floor; then bend the left leg and lean forward by moving your hips toward the wall. Hold, then repeat on the other side for 15 counts.



## Toe Touch

Slowly bend forward from your waist, letting your back and shoulders relax as you stretch toward your toes. Reach down as far as you can and hold for 15 counts.



## Side Stretch

Open your arms to the side and continue lifting them until they are over your head. Reach your right arm as far upward toward the ceiling as you can for one count. Feel the stretch up your right side. Repeat this action with your left arm.

## Features:

- Display Monitor for Real-Time Progress
- 8 Resistance Levels
- Whisper Quiet with Smooth Gliding Motion
- Quick and Easy Assemble up to 3-5 minutes
- Carrying Handle for Easy Portability
- Low-Impact Exerciser
- Pedal Bike Cycle Motion
- Lightweight, Durable and Portable
- Ergonomic Design with Built-in LCD Monitor
- LCD Monitor with 4 Functions: Time, Count, Calories & Total Count
- Low Profile Elliptical Trainer
- Stable, Safe and Simple to Use
- Designed for Under Desk Use
- Machine for Home and Office Workout
- With Resistance Band for more Exercise Workout
- Exercise while Working or Eating your Favorite Meal
- Fits into Everyday Life, Office Desk, or Home Couch
- Help People with Limited Mobility Looking to Revitalize & Build Muscle Strength

## What's in the Box:

- (2) M8x16 Bolt
- (2) Resistance Band
- (1) Allen Key

## Technical Specs:

- Construction Material: Engineered ABS
- Adjustable Resistance Levels: 8 Levels
- Max. Weight Capacity: 300 lbs.
- Monitor Requires 1.5V LR44 Magnetic Battery (Included)
- Product Dimension (L x W x H): 23.62" x 16.92" x 11.81" -inches



This product can expose you to a chemical or group of chemicals, which may include "Di (2-ethylhexyl) phthalate (DEHP)" which is known in the state of California to cause cancer, birth defects, or other reproductive harm.

**WARNING:** For more info, go to <https://www.p65warnings.ca.gov/>.





# SereneLife

**Questions? Issues?**

We are here to help!

Phone: (1) 718-535-1800

Email: [support@pyleusa.com](mailto:support@pyleusa.com)