

## QUICK SETUP GUIDE

# Dual-Tap Beer Kegerator/Beverage Cooler

NS-BK2TSS6

Congratulations on your purchase! Your NS-BK2TSS6 kegerator/beverage cooler is designed for years of fun and trouble-free performance. This *Quick Setup Guide* is provided to help you get your kegerator up and running quickly. If you need more help, however, take a look at the online manual, located at [www.insigniaproducts.com](http://www.insigniaproducts.com).

### FEATURES

- Dual taps for multiple kegs
- Convertible to refrigerator/beverage cooler
- Adjustable thermostat for ideal temperature

### PACKAGE CONTENTS

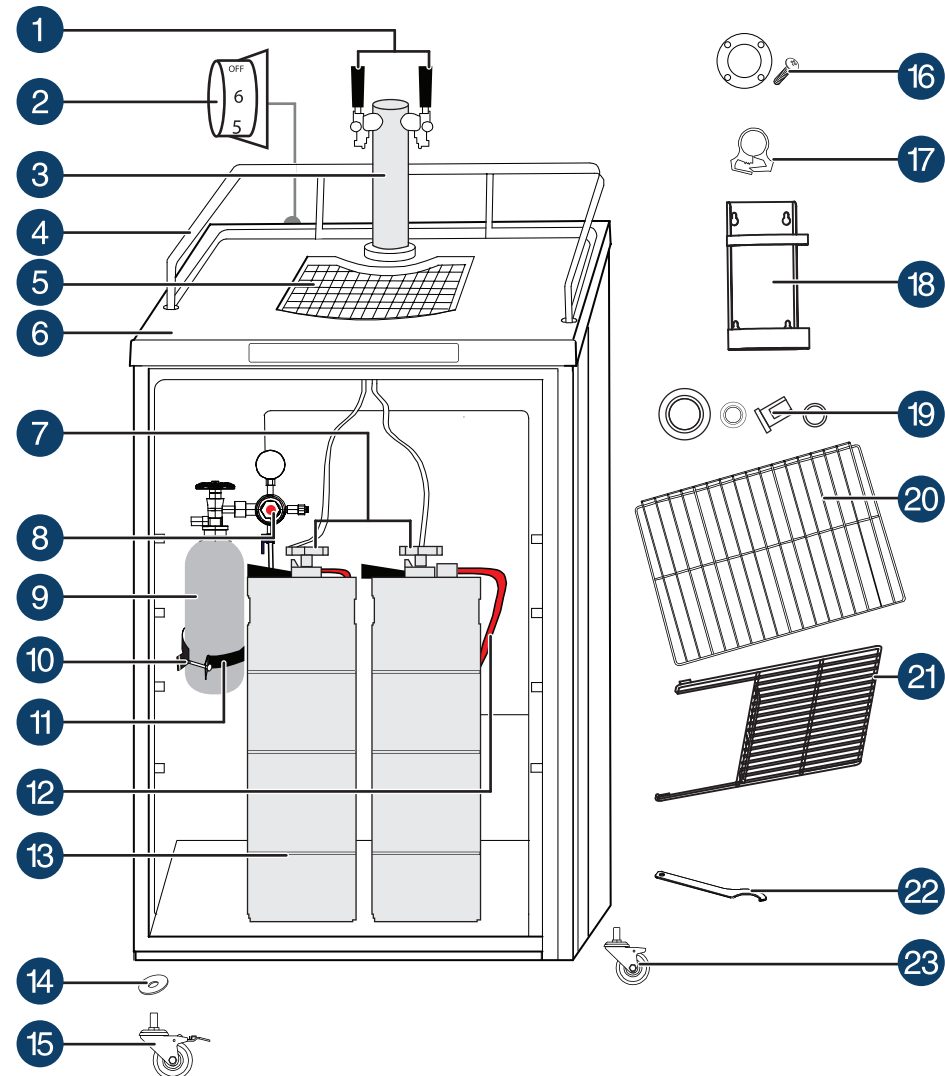

- |  |  |
|--|--|
| 1 Beer tap handles                     | 13 Beer keg (not included)               |
| 2 Thermostat                           | 14 Metal washers for locking casters (2) |
| 3 Draft arm assembly                   | 15 Locking casters (2)                   |
| 4 Guardrail                            | 16 Beer gasket with screws (4)           |
| 5 Drip tray (2 pieces)                 | 17 Hose clamp                            |
| 6 Worktop                              | 18 CO <sub>2</sub> back tank retainer    |
| 7 Keg couplers (2)                     | 19 Extra valve washers (2 of each)       |
| 8 CO <sub>2</sub> tank regulator       | 20 Wire shelf                            |
| 9 CO <sub>2</sub> tank (shipped empty) | 21 Wire half-shelf                       |
| 10 Bolt and nut for retainer           | 22 Metal wrench (for cleaning)           |
| 11 CO <sub>2</sub> tank retainer       | 23 Casters (2)                           |
| 12 CO <sub>2</sub> gas lines           |  |

## Before assembly



**Fill the CO<sub>2</sub> tank**  
See your local beer keg provider, air/gas or welding supplier, or sporting goods store.



**Allow for space**  
Make sure that there is 3" between the back and sides of the kegerator and any surrounding walls.



**Do not use an extension cord**



**Find a suitable location**  
Position the kegerator away from direct sunlight and sources of heat, and avoid positioning the kegerator in moist areas.

### You will need

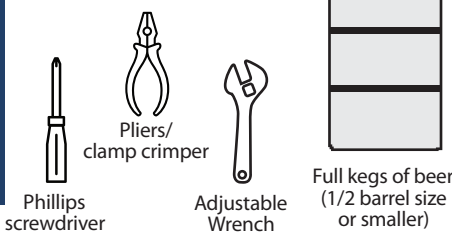

## Assembling your kegerator

### 1 INSTALLING THE CASTERS (OPTIONAL)

- 1 Tip the kegerator/beverage cooler onto its side on a soft surface to protect it from scratches.
- 2 Unscrew and remove the black front feet. Keep them in a safe place in case you want to remove the casters and use the front feet.
- 3 Attach the two metal washers (included) to the locking casters to prevent scratching the cabinet, then install the two locking casters in the front positions on the bottom of the kegerator/beverage cooler (closest to the door).
- 4 Install the other two casters in the rear positions on the bottom of the kegerator/beverage cooler.

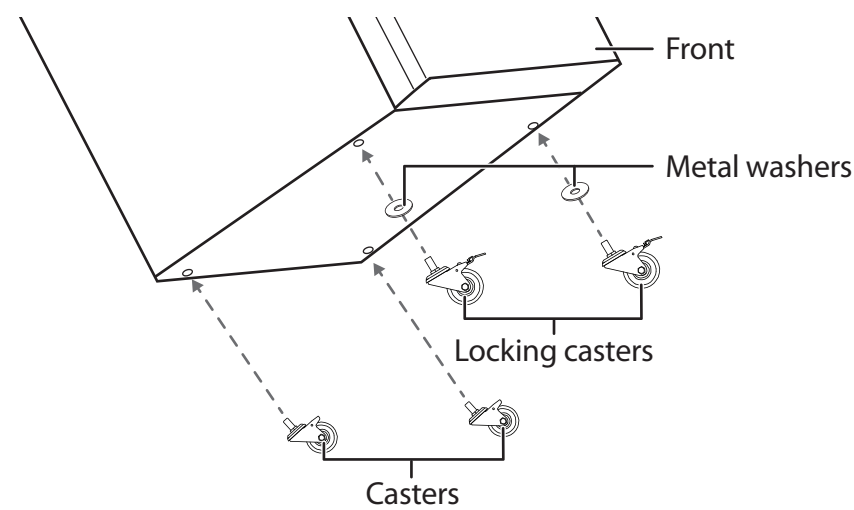

- 5 With all four casters tightened evenly, stand the unit in the upright position.
- 6 Step on the front of the locking casters to lock the kegerator/beverage cooler into place or step on the back to unlock the kegerator/beverage cooler.

### 2 ATTACHING THE GUARD RAIL

Place the guard rail into the holes on the top of the kegerator.

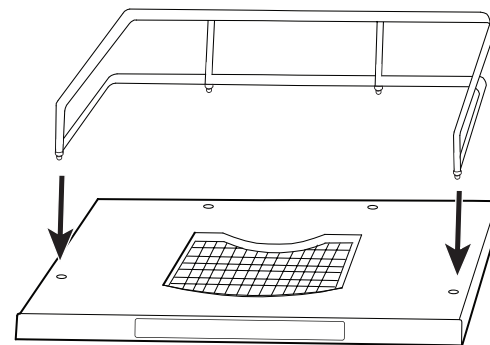

### 3 INSTALLING THE DRAFT ARM ASSEMBLY

- 1 Remove the cabinet plug from the top of the kegerator.
- 2 Align the beer gasket to the four holes on the top of the cabinet.
- 3 Pass both the wing nut and the beer tube (both are attached to the draft arm assembly) through the hole on the worktop until the draft arm assembly is resting on the top of the cabinet.
- 4 Align the holes in the draft arm with the holes in the gasket, then attach the draft arm to the worktop with the four screws provided.
- 5 Attach the black plastic beer tap handles to the top of the faucet, tightening by hand. Hold the silver ring snug so it does not move.

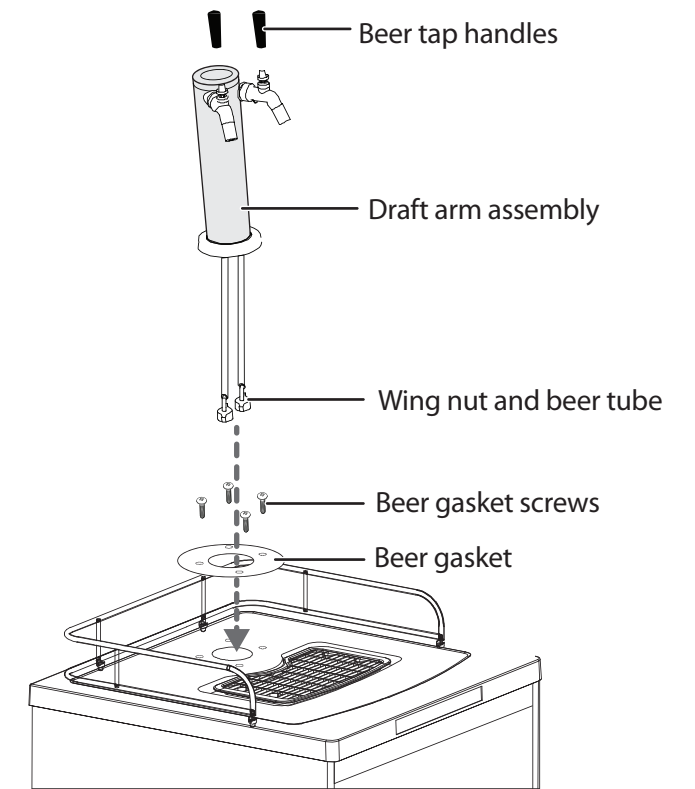

### 4 INSTALLING THE CO<sub>2</sub> REGULATOR & TANK

**Note:** The CO<sub>2</sub> tank (provided) is empty when you receive it. Visit your local beer keg provider, air/gas or welding supplier, or sporting goods store to get it filled.  
**Caution:** Before installing the CO<sub>2</sub> regulator and tank, be sure to review important safety tips in the manual.

- 1 Feed the hose clamp over one end of the CO<sub>2</sub> gas line.
- 2 Attach that end to the gas line connector on the CO<sub>2</sub> regulator.

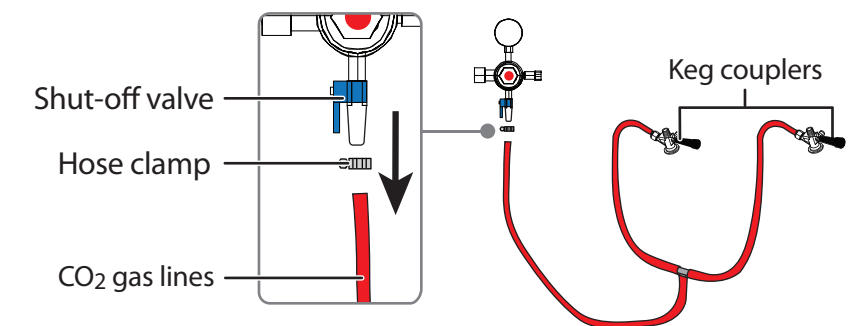

- 3 Tighten the clamp to prevent leaks. Leave about 1/2 inch between the top of the clamp and the end of the hose. You may need to squeeze with a pliers or crimper.
- 4 Attach the CO<sub>2</sub> regulator to the CO<sub>2</sub> tank by screwing the regulator nut onto the tank valve and tightening with an adjustable wrench.

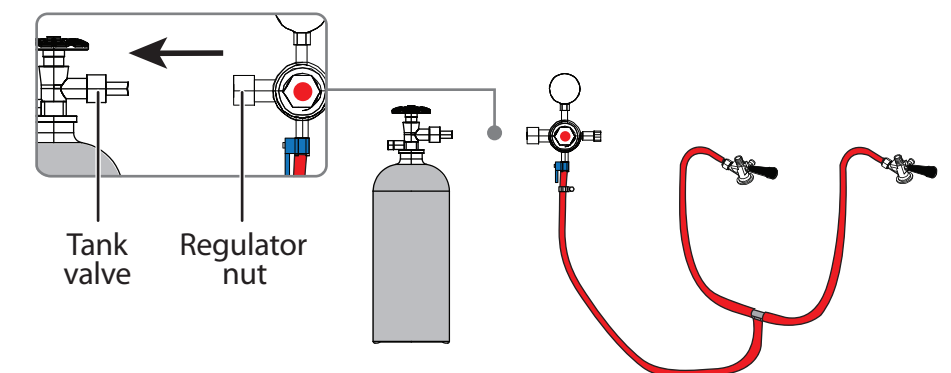

- 5 Slide the CO<sub>2</sub> tank through the retainer inside the kegerator/beverage cooler and secure it with the bolt and nut. Position the tank so that you can read the numbers on the gauge and have easy access to the shut-off valve.

#### OR

Install the CO<sub>2</sub> tank retainer on the back of the kegerator/beverage cooler to provide for extra space inside the unit. Refer to the manual for additional information.

# Assembling your kegerator (cont.)

## 5 INSTALLING THE KEG COUPLER

This kegerator accepts almost all brand name kegs, except for Coors. Here's what will fit in your kegerator:

BARREL SIZE	1/2	1/4 (short, pony)	1/4 (slim)	1/6	1/8
HOW MANY WILL FIT	1	1	1*	2*	2*
GALLONS	15.5	7.8	7.8	5.2	4.0
12 oz GLASSES	164	82	82	55	41

**TIP:** Keg sizes change so be sure to measure the inside of your kegerator and kegs to get a perfect fit.

\*You can have a 1/4 (slim), and a 1/6 or 1/4 (slim), and a 1/8 in your kegerator at the same time.

- 1 Insert the keg coupler into the neck of the beer keg and turn it clockwise to lock it into position. Make sure that the washer is in the connector on the top of the keg coupler.

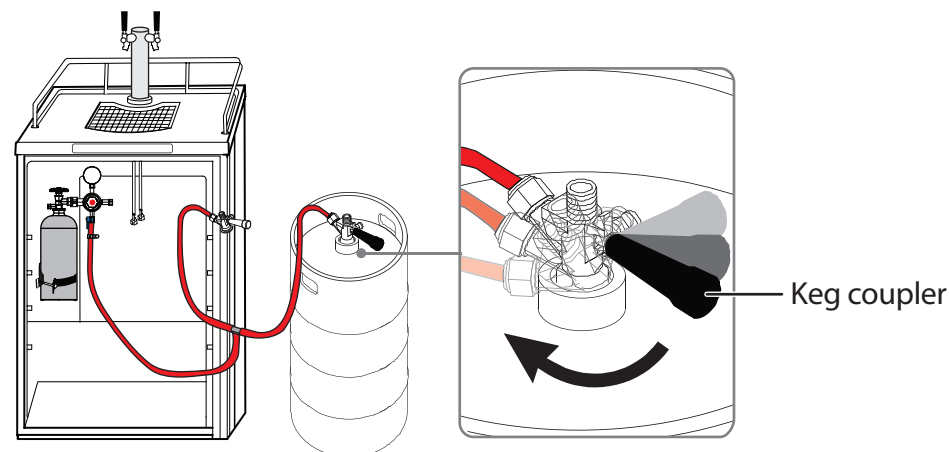

- 2 Insert the beer tube into the top of the keg coupler. Tighten the wing nut.

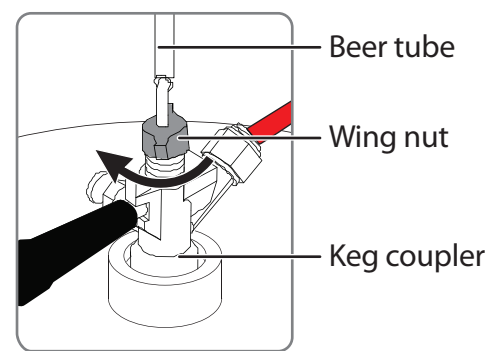

- 3 Repeat steps 1-2 if you have a second keg.
- 4 Pull the black handle on the keg coupler and press it downward until it locks into position. The keg is now tapped.

**Note:** If beer comes up through the top of the wing nut, remove the wing nut, reposition the washer, then reattach the wingnut.

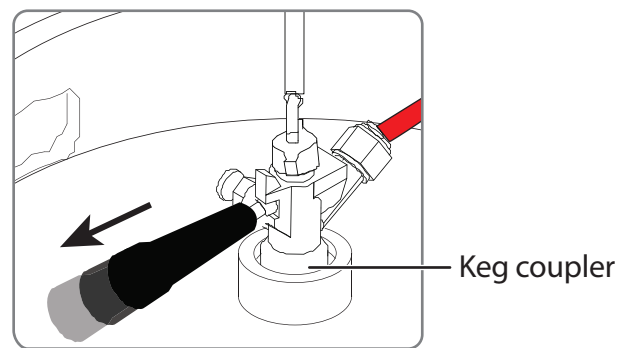

- 5 Insert the keg(s) into the cooler.

## 6 ADJUSTING THE CO<sub>2</sub> REGULATOR

- 1 Make sure that the shut-off valve is closed (sideways if closed, down if open), then slowly turn the main valve on the CO<sub>2</sub> tank counter-clockwise until it is fully open.

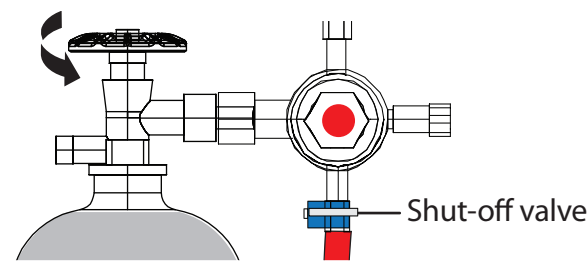

- 2 Open the shut-off valve to allow gas to flow into the keg.

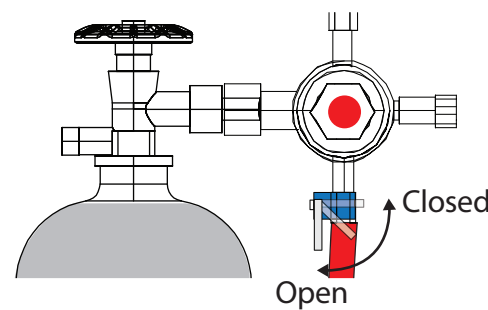

- 3 Release the adjustment lock nut, behind the regulator screw, by turning it clockwise about 5-7 turns.
- 4 Turn the regulator screw clockwise to increase pressure. The needle on the gauge starts to climb. Set the gauge to 10-12 PSI.

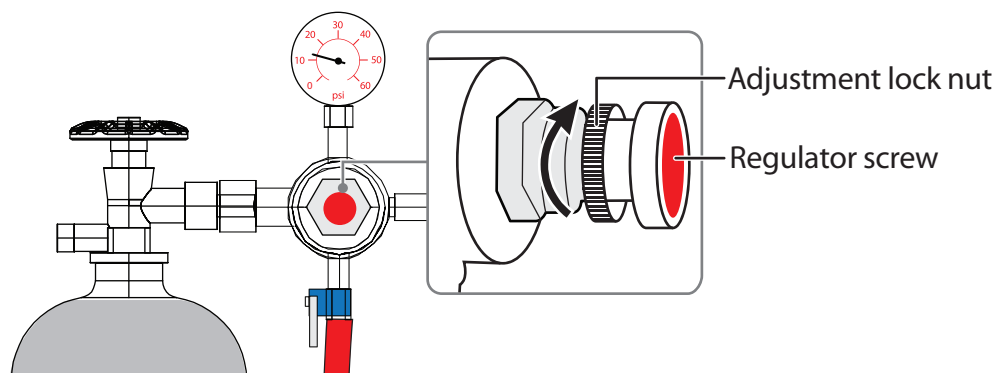

- 5 When the tank is at the correct pressure, tighten the adjustment lock nut by turning it counter-clockwise.
- 6 Allow several minutes for the keg to pressurize. The gauge may show a drop in pressure while this happens. Adjust as needed. **Note:** Listen for a hissing sound at all connections to determine if there are any leaks.
- 7 Plug the kegerator/beverage cooler into a 120V, 60Hz, 15Amp grounded outlet.

## 7 SETTING THE TEMPERATURE

The optimum temperature for serving draught beer is between 34° F - 38° F (1.1° C - 3.3° C).

- 1 Plug in your kegerator, set the thermostat to maximum (6), then let it run for 48 hours before making any temperature adjustments.

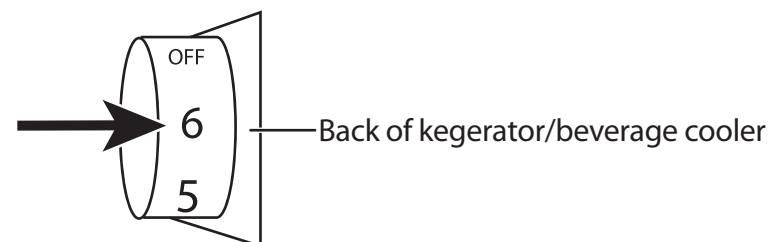

- 2 After it is fully cooled, adjust the thermostat to the desired temperature.
- 3 Turn the thermostat to the OFF position to turn off your kegerator. Turning the thermostat OFF stops the cooling cycle but does not shut off the power to your cooler.

**Note:** If the kegerator/beverage cooler is unplugged or loses power, wait three to five minutes before restarting it. If you try to restart before this time delay, the kegerator will not start. To change the thermostat setting, adjust it one increment at a time. Allow several hours for the temperature to stabilize between adjustments.

Cut this out and attach it to your kegerator for easy access to tips and help!

## Tips

### HOW TO GET A GREAT POUR

Pouring a proper glass of beer is very important, not only for presentation, but for taste.

**TIP:** Make sure your glassware is always clean and rinsed.

- 1 Hold the glass at a 45° angle.
- 2 Grasp the handle at the bottom and open the tap quickly.
- 3 Once your glass is half-full, gradually bring the glass upright, and aim for the middle to start forming the head. Slowly lower the glass as you approach your finish to improve the head even more.
- 4 When your glass is full, close the tap quickly.

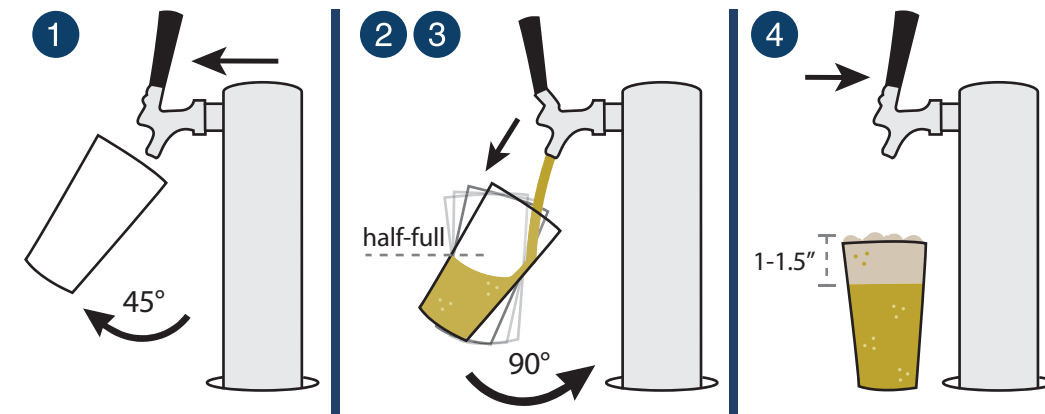

### USE DIFFERENT GLASSES FOR DIFFERENT BEERS

You wouldn't believe how much a proper glass and temperature will change the taste of your beer.

**Lagers**  
(35-40° F)



Often labeled simply as "beer." Examples include Budweiser, Stella Artois, Beck's, Corona, Heineken, and Foster's.

**Stouts**  
(55° F)



Dark beers made using roasted malt or barley. Examples include porters and Guinness.

**Ales**  
(45-55° F)



Includes brown ales (such as Newcastle), golden ales, pale ales (IPA), mild ale, and barley wines.

**Craft Beers**  
(38-41° F)



Includes craft, micro, and nano brewery beers, often only available regionally or locally.

### PREVENTING BAD BEER

PROBLEM	POSSIBLE CAUSE	POSSIBLE SOLUTION
 Too much head	Improper regulator setting	Make sure that the (CO <sub>2</sub> ) pressure is between 10 and 12 PSI.
	Pressure build up	Activate the pressure relief valve located on the keg coupler for three seconds.
	Warm beer	Make sure the temperature is between 34°F and 38° F.
	Improper pour	Open the tap quickly and completely.
 Flat beer. No head.	Greasy Glasses	Wash glasses thoroughly, then air dry. Rinse in fresh cold water just before serving.
	Improper pour	Open the tap quickly and completely.
	Not enough pressure	Increase the pressure or refill the CO <sub>2</sub> tank if empty.
 Abnormal beer taste and/or smell.	System requires cleaning	Refer to the manual section on "Maintaining your kegerator/beverage cooler."
	Old beer	Buy a new keg.

### ONE-YEAR LIMITED WARRANTY

Visit [www.insigniaproducts.com](http://www.insigniaproducts.com) for details.

### CONTACT INSIGNIA:

For customer service, call 1-877-467-4289 (U.S. and Canada) or 01-800-926-3000 (Mexico)  
[www.insigniaproducts.com](http://www.insigniaproducts.com)

INSIGNIA is a trademark of Best Buy and its affiliated companies  
Distributed by Best Buy Purchasing, LLC  
7601 Penn Ave South, Richfield, MN 55423 U.S.A.  
©2016 Best Buy. All rights reserved.  
**Made in China**