

QUICK SETUP GUIDE

Wi-Fi Camera

NS-CH1IPC8

PACKAGE CONTENTS

- IP camera
- Magnetic base
- Wall mount
- Reset tool
- Power cord and AC adapter
- Screws with anchors (2 sets)
- *Quick Setup Guide*

FEATURES

- Live video viewing lets you check your home at any time
- Motion detection records when activity is sensed
- Motion alerts with video give you peace of mind
- 120-degree viewing angle captures all the action
- 2-way audio lets you listen in and speak to people or pets at home
- Micro SD card backs up encrypted video in case of network outage
- For indoor use only

SYSTEM REQUIREMENTS

- Home Wi-Fi network
- Insignia Connect app (free download at connect.bestbuy.com/setup)
The Insignia Connect app tracks status information for all of your Insignia smart home devices in one place. Signing into a Best Buy account is required for remote access and to keep your data secure.
- iOS 10.0 or later
OR
Android 6.0.1 (Marshmallow) or later

ELECTRICAL REQUIREMENTS

Make sure that the power cord will be able to reach a power outlet from your mounting location.

MOUNTING TOOLS

Note: You don't need any tools to mount to a flat surface. If mounting to your ceiling or wall, you'll need a:

- Drill with 4.2 mm drill bit
- Hammer (for anchors)
- Flathead screwdriver
- Phillips screwdriver

SETTING UP YOUR IP CAMERA

- 1 Connect your mobile device to a Wi-Fi network.
- 2 Type connect.bestbuy.com/setup in the search bar of your device's browser and follow the on-screen instructions to download the Insignia Connect App.
- 3 Plug your IP camera into a wall outlet using the included power cord and adapter.

- 4 Open the app and register or sign in with your existing Best Buy account info. Follow the on-screen instructions to complete setup.

Note: If you plan to access your camera on multiple devices, you must sign into the same Best Buy account.

MOUNTING YOUR IP CAMERA

Using the magnetic base, you can place your indoor camera on a flat surface or mount it to the wall or ceiling. Before you mount, make sure that the power cord will be able to reach a power outlet.

Flat surface

- 1 Place the magnetic mount on a flat surface.

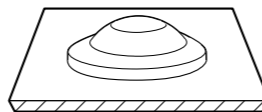

- 2 Attach the camera to the magnetic base.

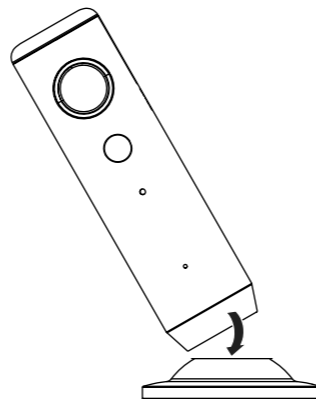

Mount to ceiling

Note: Flip the video in your app settings so your video will be right-side up.

- 1 Insert a screwdriver into the slot by the cover, and pry the cover from the magnetic mount.

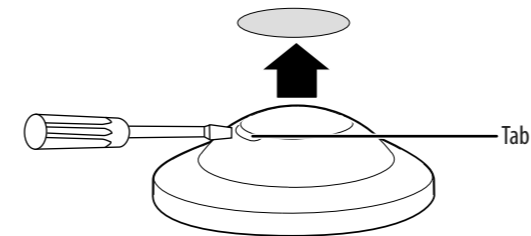

- 2 Drill a hole in the ceiling with a 4.2 mm drill bit where you want to mount your camera.
- 3 Insert an anchor into the hole, then secure the magnetic mount to the ceiling with a screw (included).

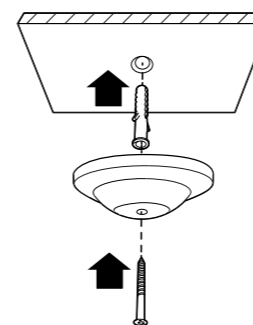

- 4 Push the cover back onto the magnetic base.

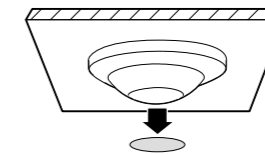

- 5 Attach the camera to the magnetic base.

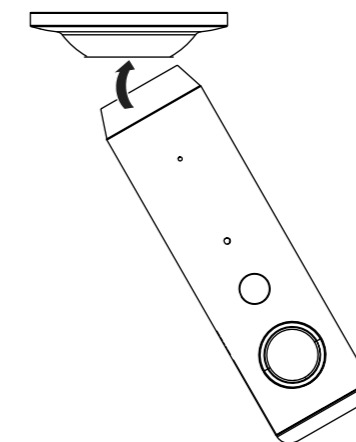

Mount to wall

- 1 Remove the wall plate from the back of the wall mount.

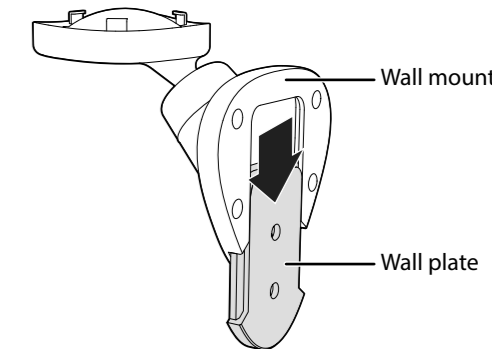

- 2 Using the wall plate as a guide, mark and then drill two holes with a 4.2 mm drill bit where you want to mount your camera.

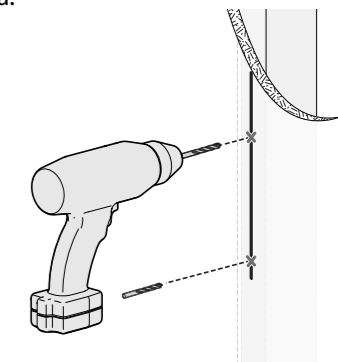

3 Insert the two anchors into the holes, then secure the wall plate to the wall with the two screws.

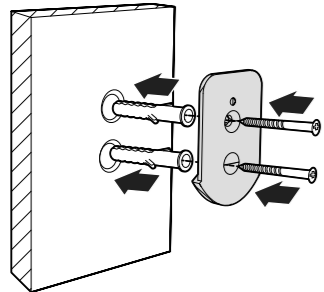

4 Align the bottom of the camera with the tabs on the mount, and then twist the camera to secure.

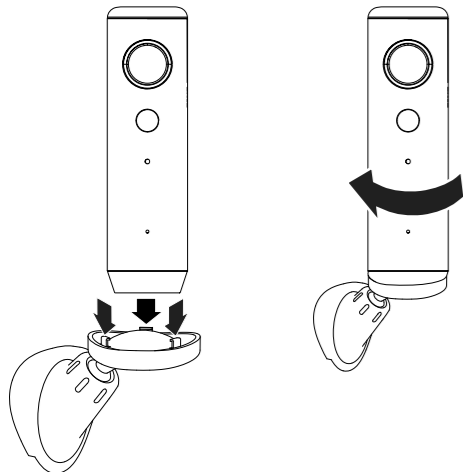

5 Slide the wall mount onto the wall plate.

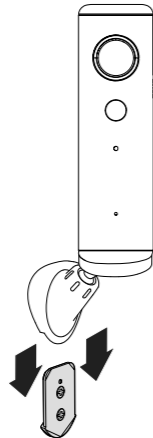

INSERTING A MICRO SD CARD

- 1 Pull open the cover to the micro SD slot on the back of your IP camera.
- 2 Insert a micro SD card (up to 64 GB) into the slot until it clicks into place.

USING YOUR IP CAMERA

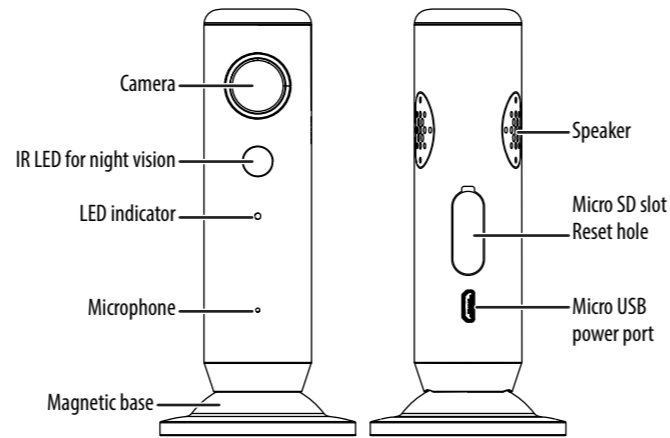

LED status

| LED INDICATOR | STATUS |
|---------------------|--|
| Blinks blue slowly | Searching for a Wi-Fi connection |
| Blinks blue quickly | Connecting to Wi-Fi |
| Solid blue | Connected to a Wi-Fi network |
| Solid red | Camera powering up (may last up to 20 seconds) |
| Blinks red quickly | Upgrading firmware |

RESETTING TO FACTORY DEFAULTS

Resetting to factory defaults disconnects your camera from your Insignia Connect app and resets Wi-Fi and system settings. Video stored on the cloud is not affected.

- 1 Pull open the cover to the reset hole on the back of your IP camera.
- 2 Push the reset tool or a paper clip into the reset hole and hold for five seconds.

FIND YOUR USER GUIDE ONLINE

For more information about using your IP camera and its settings, check your online *User Guide*:

- 1 Go to www.insigniaproducts.com.
- 2 Use the search bar to find **NS-CH1IPC8**.
- 3 Select **Support & Downloads**.
- 4 Next to *User Guide*, select the language you want.

SPECIFICATIONS

See your *User Guide* for a complete list of specifications.

TROUBLESHOOTING

See your *User Guide* for Troubleshooting information.

LEGAL NOTICES

FCC Statement

Warning: Changes or modifications to this unit not expressly approved by the party responsible for compliance could void the user's authority to operate this equipment.

Note: This equipment has been tested and found to comply with the limits for a Class B digital device, pursuant to Part 15 of the FCC Rules. These limits are designed to provide reasonable protection against harmful interference in a residential installation. This equipment generates, uses, and can radiate radio frequency energy and, if not installed and used in accordance with the instructions, maybe cause harmful interference to radio communications.

However, there is no guarantee that interference will not occur in a particular installation. If this equipment does cause harmful interference to radio or television reception, which can be determined by turning the equipment off and on, the user is encouraged to try to correct the interference by one or more of the following measures:

- Reorient or relocate the receiving antenna.
 - Increase the separation between the equipment and receiver.
 - Connect the equipment into an outlet on a circuit different from that to which the receiver is connected.
 - Consult the dealer or an experienced radio/TV technician for help.
- This device complies with Part 15 of the FCC Rules. Operation is subject to the following conditions:
- (1) this device may not cause harmful interference, and
 - (2) this device must accept any interference received, including interference that may cause undesired operation.

The device has been evaluated to meet general RF exposure requirements. The device can be used in portable exposure condition without restriction.

Industry Canada Compliance IC Statement

This device complies with Industry Canada's licence-exempt RSS standard(s). Operation is subject to the following two conditions:

- (1) this device may not cause interference, and
- (2) this device must accept any interference, including interference that may cause undesired operation of the device.

Le présent appareil est conforme aux CNR d'industrie Canada applicables aux appareils radio exempts de licence. L'exploitation est autorisée aux deux conditions suivantes :

- (1) l'appareil ne doit pas produire de brouillage, et
- (2) l'utilisateur de l'appareil doit accepter tout brouillage radioélectrique subi, même si le brouillage est susceptible d'en compromettre le fonctionnement.

ONE-YEAR LIMITED WARRANTY

Visit www.insigniaproducts.com for details.

CONTACT INSIGNIA:

For customer service, call 1-877-467-4289 (U.S. and Canada) or 01-800-926-3000 (Mexico)

www.insigniaproducts.com

INSIGNIA is a trademark of Best Buy and its affiliated companies
 Distributed by Best Buy Purchasing, LLC
 7601 Penn Ave South, Richfield, MN 55423 U.S.A.
 ©2017 Best Buy. All rights reserved.

Made in China