

Congratulations on your purchase of an Insignia 2.1 Channel Soundbar with Wireless Subwoofer.

PACKAGE CONTENTS

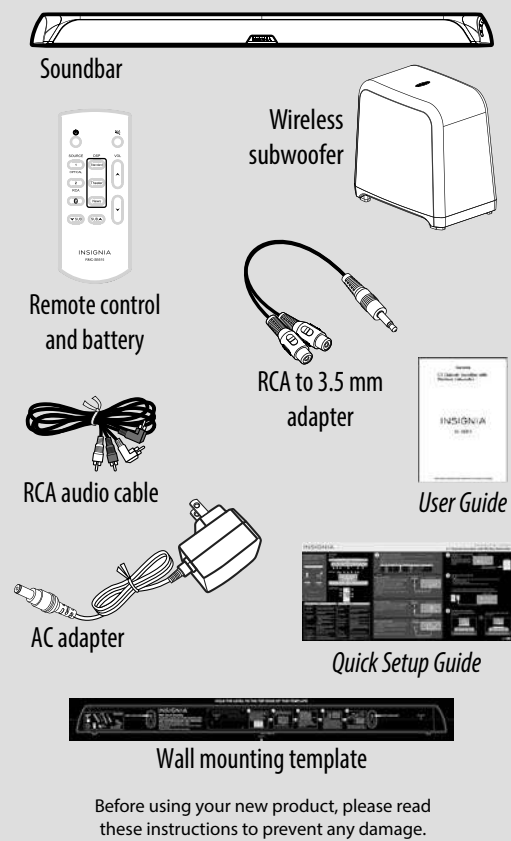

FEATURES

Front view

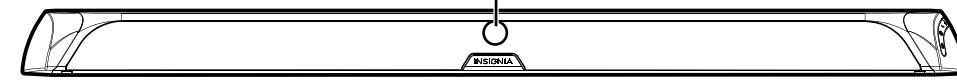

Back view

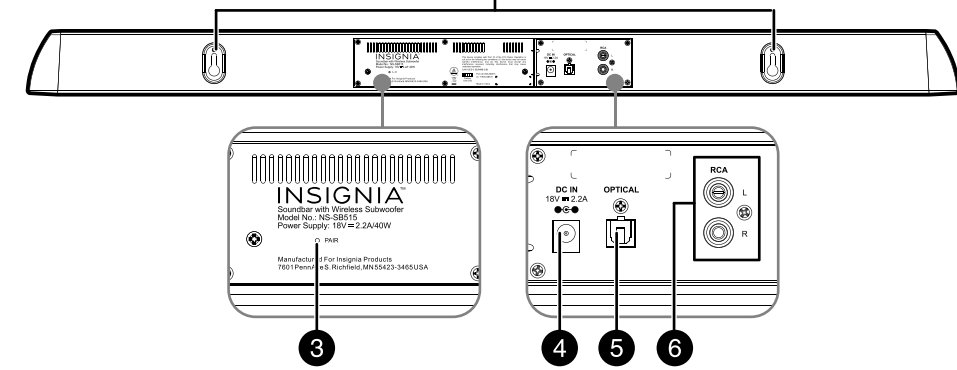

Side view

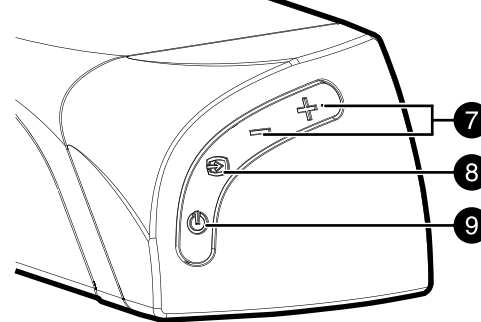

Remote control

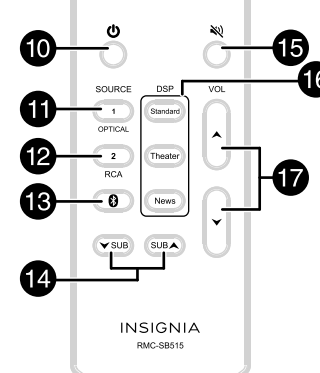

#	ITEM	DESCRIPTION
1	LED indicator	Indicates when settings are changed on the soundbar.
2	Hanging brackets	Use to hang the soundbar on a wall.
3	Pairing button	Use to pair the soundbar to subwoofer if not automatically connected when turned on.
4	DC IN jack	Connect the AC adapter to this jack to power the soundbar.
5	SOURCE 1: OPTICAL jack	If the TV, or other audio source device, has an Optical Out jack, connect a digital optical cable to the source device and this jack.
6	SOURCE 2: RCA (R and L) jacks	If the TV, or other audio source device, has RCA Out jacks, connect the RCA cables to the source device and these jacks.
7	+/-	Press to increase or decrease the volume.
8	source button	Press repeatedly to cycle through the available sound sources: • Source 1 - Optical • Source 2 - RCA • Bluetooth
9	power button	Press to turn on the soundbar. Press again to put the soundbar into standby mode.

#	ITEM	DESCRIPTION
10	power button	Press to turn on the soundbar. Press again to put the soundbar into standby mode.
11	SOURCE - OPTICAL	Press to select the digital optical sound source for your soundbar.
12	SOURCE - RCA	Press to select the RCA sound source for your soundbar.
13	SOURCE Bluetooth	Press to select the Bluetooth sound source for your soundbar.
14	SUB ▲ / SUB ▼	Press to adjust the volume of the wireless subwoofer.
15	Mute	Press to mute the sound from the soundbar. Press again to restore the sound.
16	DSP buttons	Press Standard to select Standard Digital Signal Processor (DSP) sound mode. Press Theater to select the Theater Digital Signal Processor (DSP) sound mode. Press News to select the News Digital Signal Processor (DSP) sound mode.
17	VOL ▲ / ▼	Press to adjust the volume of your soundbar.

1 CONNECT THE SOUNDBAR

Look at the back of your source device, such as a TV, DVD/Blu-ray player, or cable box, to identify your audio OUT ports. Choose one connection option below that fits your audio source. You can connect several devices and switch the sound source as needed.

CAUTION: Turn off or unplug all devices while making connections.

NOTE: If you are mounting the soundbar on a wall, you must use the included right-angle cable connectors for the RCA cable connections.

AUDIO QUALITY	JACK TYPE (on source device)	CABLE
BEST		Digital optical cable (not included)
GOOD		3.5 mm audio cable (adapter included)
GOOD		RCA audio cable (included)

- PICK ONE -

Digital Optical connection (BEST)

- 1 Connect one end of the digital optical cable (not included) to your soundbar. Connect the other end into the **Digital Optical Output** port on your audio source device.
- 2 Change the device's audio output to 'PCM' format (typically found in audio settings). Refer to the documentation that came with your audio source device for more information.
- 3 Go to step 2, *Connect the AC Adapter*.

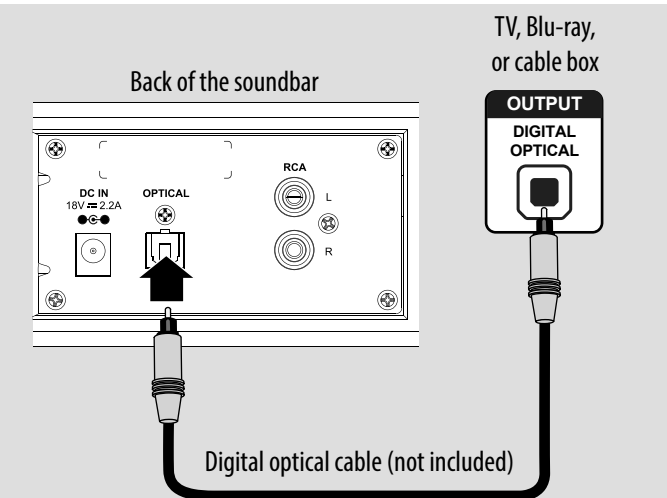

- OR -

3.5 mm connection (GOOD)

- 1 Connect the right-angled connectors of the RCA audio cable to your soundbar.
 - 2 Connect the other ends of the cables to the RCA to 3.5 mm adapter, then connect the other end to the **headphone** or **AUX Output** on your audio source device.
 - 3 Go to step 2, *Connect the AC Adapter*.
- NOTE:** Make sure that the cable ends match the color of the ports.

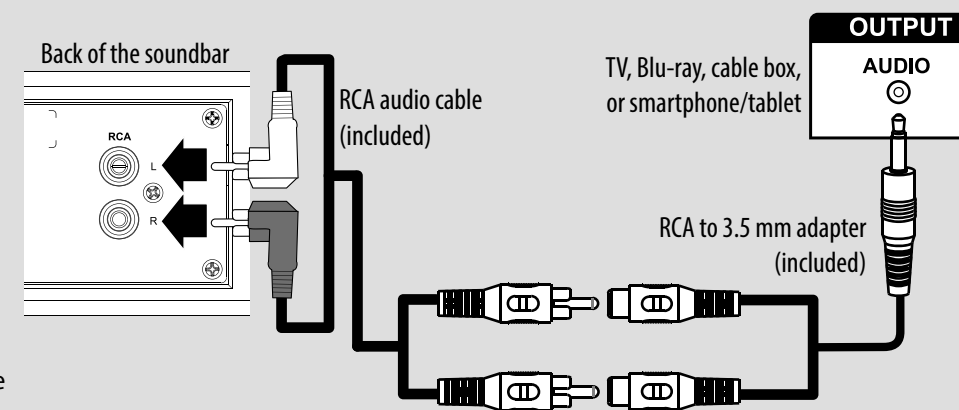

- OR -

RCA connection (GOOD)

- 1 Connect the right-angled connectors of the RCA audio cable to your soundbar.
 - 2 Connect the other end of the RCA audio cable into the **Audio Output** ports on your audio source device.
 - 3 Go to step 2, *Connect the AC Adapter*.
- NOTE:** Make sure that the cable ends match the color of the ports.

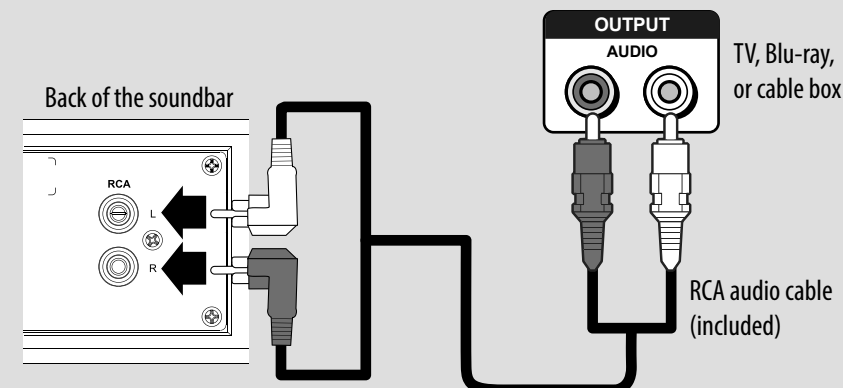

2 CONNECT THE AC ADAPTER

CAUTIONS:

- Make sure that the electrical outlet matches the AC adapter's input requirements of 100-240 V, 50/60 Hz before connecting.
- Use only the AC adapter provided.
- Plug in the AC adapter only after all other connections have been made.

- 1 Connect the AC adapter to the DC IN jack on the back of the soundbar.
- 2 Plug the other end of the AC adapter into a power outlet or surge protector.

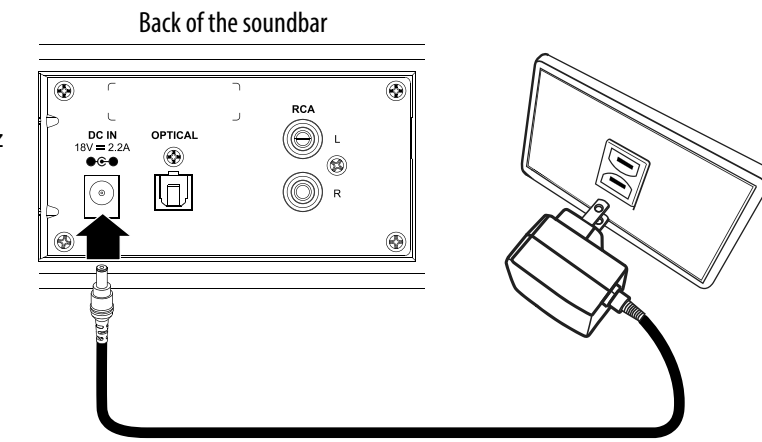

3 CONNECT THE SUBWOOFER

To connect the subwoofer, plug in the power cord. The subwoofer receives a wireless audio signal from the soundbar.

Note: If your subwoofer does not connect automatically, see "Troubleshooting".

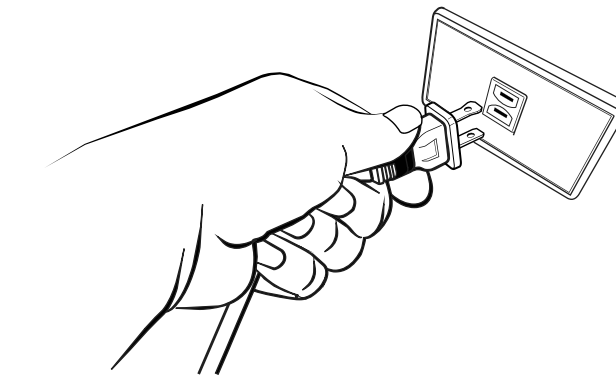

4 CONNECTING YOUR SOUNDBAR USING BLUETOOTH (OPTIONAL)

Pairing your devices

- 1 Turn on your soundbar.
- 2 Place your Bluetooth device within 30 ft. (10 m) of your soundbar.
- 3 Select **Bluetooth** as the input source by pressing the Bluetooth button on the remote control or the source button on the soundbar. The blue Bluetooth indicator on the soundbar blinks slowly.
- 4 Navigate to your device's Bluetooth settings, turn on Bluetooth, then search for available devices. For additional information on pairing your device, refer to your devices' documentation.
- 5 On your Bluetooth device, select "NS-SB515" from the device list. Repeat step 2 if "NS-SB515" is not displayed.
- 6 If a PIN code is requested, enter "0000."
- 7 When pairing is completed the Bluetooth indicator on the top of your soundbar lights solid blue.

NOTES:

- Some devices, such as an iPhone, connect immediately after pairing, other devices, such as notebook computers, may ask you if you wish to connect. In this instance, the Bluetooth indicator continues to blink until a connection is established.
- When you turn on your soundbar, it automatically connects to the last connected device if that device is in range. To connect to a different paired device, you have to turn off Bluetooth or unpair from the currently paired device and manually connect to the other paired device.
- When a call is received while playing music through a phone, the music stops automatically.
- When the call ends, depending on the setting of your phone, the current track may resume playback.

Disconnecting your devices

- Turn off the Bluetooth function on your device.

NOTE: For more information about using Bluetooth, see the *User Guide*.

5 POSITIONING THE SOUNDBAR AND SUBWOOFER

The soundbar can be mounted on a wall.

For instructions on mounting your soundbar, see page 18 of the *User Guide*.

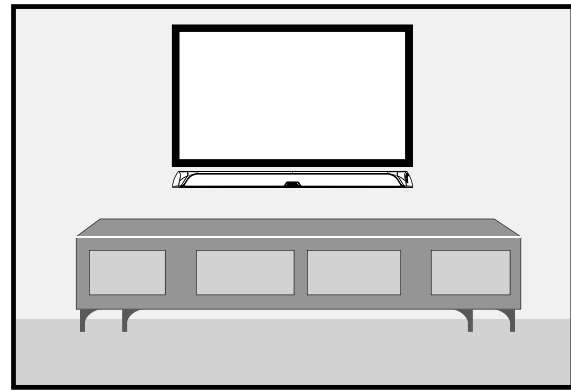

- OR -

The soundbar can be set on a flat surface (go to Step 5)

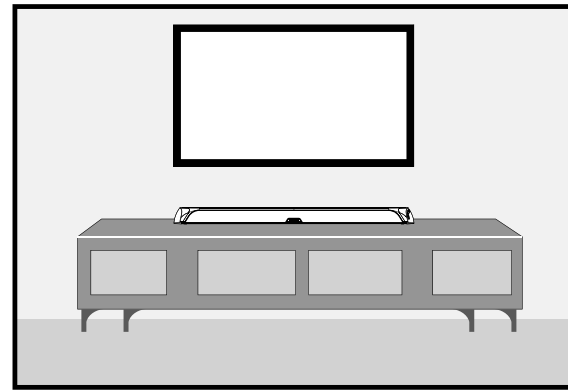

*Because the low frequency sound is non-directional, the subwoofer can be placed anywhere in the room.

6 USING YOUR SOUNDBAR

Using the remote control

- 1 Remove the plastic tab from the battery compartment before using the remote control for the first time.
- 2 Point the remote control directly at the IR sensor on the front of the soundbar. You must be within approximately 23 ft. (7 m) of the soundbar.

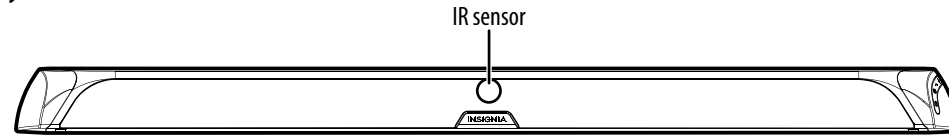

Listening to your soundbar

- 1 Press the **Power** button to turn on your soundbar. The power indicator turns blue (Bluetooth source) or green (RCA/Optical source).
- 2 Turn on the audio source device connected to your soundbar and begin playback.
- 3 Press the **Source** button on the soundbar repeatedly to select the audio source or press the selected source button on the remote control.

NOTE: If you use the OPTICAL connection, you must change your device's audio output setting to "PCM" format. Refer to the manual you received with the output device for additional information.
- 4 Adjust the volume on your soundbar or the audio device to a comfortable level.

WARNING: Continuous use of high volume sound may permanently damage your hearing.
- 5 Press the **Power** button again to turn off your soundbar. The standby indicator lights red.

LED COLOR	ACTION	DESCRIPTION
Red	Solid	• Standby/power off (remains on in standby mode)
	Flashes	• Mute (not source dependent)
Green	Lights for 10 seconds	RCA OR OPTICAL SOURCE SELECTED
	Lights for three seconds	• Power on
	Flashes on then off	• Maximum or minimum volume level is reached • RCA/Optical connected • Soundbar volume up/down • Subwoofer volume up/down
Blue	Lights for 10 seconds	BLUETOOTH SOURCE SELECTED
	Lights for three seconds	• Power on
	Flashes on then off	• Maximum or minimum volume level is reached • Bluetooth connected • Soundbar volume up/down • Subwoofer volume up/down
	Blinking	• Bluetooth in pairing mode
Purple	Flashes on then off	• Standard, Theater, or News DSP mode selected (not source dependent)

TROUBLESHOOTING

Check this list for a possible troubleshooting solution before calling for service: 1-877-467-4289 (U.S. and Canada) or 01-800-926-3000 (Mexico) Also, check the online FAQs at www.insigniaproducts.com.

PROBLEM	POSSIBLE SOLUTIONS
The power does not come on.	<ul style="list-style-type: none"> • Make sure that the AC adapter is securely plugged into the power outlet and the soundbar.
The remote control does not work.	<ul style="list-style-type: none"> • Remove any obstacles between the remote control and the IR sensor on the soundbar. • The remote control battery may be exhausted, replace it. • Move closer to the soundbar. The remote control is effective to approximately 23 ft. (7 m).
No sound or very low-level sound is heard from the soundbar.	<ul style="list-style-type: none"> • Make sure that you are connected to an audio OUT jack on your sound source. The port will not send audio out if it is an INPUT. • Make sure that the volume level of the soundbar is set to an adequate level. • If you are using Bluetooth, turn up the volume on your Bluetooth device. • Make sure that the volume level is not muted. Press the Mute button on the remote control to restore the sound output. • Make sure that the correct audio source is selected. Press the Source button repeatedly to switch to the correct audio source. • Make sure that the power is on and all connections are secure. • If you are using an AUX 3.5 mm cable connection, make sure that the volume is turned up on your sound source. • If you are using the OPTICAL connection, make sure that the source device's audio source is set to "PCM" format. Refer to the documentation you received with the audio source device (such as a TV or DVD/Blu-ray player) for additional information. • Make sure that the audio cable you are using is not damaged or broken. Try using another one.
Your soundbar is not working properly.	<ul style="list-style-type: none"> • Unplug the AC adapter from the wall outlet and then try plugging it in again after 30 seconds. • If you are using the OPTICAL connection, make sure that the source device's audio source is set to "PCM" format. Refer to the documentation you received with the audio source device (such as a TV or DVD/Blu-ray player) for additional information. • Make sure that the audio cable you are using is not damaged or broken. Try using another one.
The sound is breaking up or buzzing.	<ul style="list-style-type: none"> • Make sure that you are connected to an audio OUT jack on your sound source. The port will not send audio out if it is an INPUT. • Make sure that all connections are secure and cables are not broken or damaged. • If you are using the OPTICAL connection, make sure that the source device's audio source is set to "PCM" format. Refer to the documentation you received with the audio source device (such as a TV or DVD/Blu-ray player, etc.) for additional information. • Connect to a different source device (such as a TV or DVD/Blu-ray player) to see if the buzzing still occurs. If it does not, this may indicate an issue with the original source device. • Use a different connection method (for example, try Optical instead of AUX) between the soundbar and the source device to make sure that the jacks on both devices are still working. • Make sure that the audio cable you are using is not damaged or broken. Try using another one.
I can hear sound from my TV and my soundbar.	<ul style="list-style-type: none"> • Turn off or mute the internal speakers of your TV. Refer to the TV's manual for instructions.
My TV remote does not control the volume of my soundbar.	<ul style="list-style-type: none"> • In most cases, your TV remote will not control your soundbar.
No sound or low volume in Bluetooth mode.	<ul style="list-style-type: none"> • Make sure that your Bluetooth device is turned on, Bluetooth is turned on, and "NS-SB515" is selected. • Turn up the volume on your soundbar. • Turn up the volume on your Bluetooth device. • Make sure that your Bluetooth device is not muted. • Make sure that you are playing music from your Bluetooth device. • Make sure that you have selected the Bluetooth source on your soundbar. • Make sure that your soundbar is not paired to another Bluetooth device. • Make sure that your Bluetooth device is not paired to a different Bluetooth speaker.
Cannot establish Bluetooth connection.	<ul style="list-style-type: none"> • Shorten the distance between your soundbar and your Bluetooth device. • Turn your devices off, then on. Re-pair your soundbar and your Bluetooth device. • Make sure that your soundbar is not paired to another Bluetooth device. • Make sure that your soundbar and Bluetooth device are both in pairing mode. • Make sure that your Bluetooth device is not connected to any other device. • Make sure that you have selected "NS-SB515" on your Bluetooth device.
My Bluetooth device keeps unpairing.	<ul style="list-style-type: none"> • Shorten the distance between your soundbar and your Bluetooth device. • If the battery on your Bluetooth device is low, recharge the battery.
"NS-SB515" does not appear on my Bluetooth device.	<ul style="list-style-type: none"> • Shorten the distance between your soundbar and your Bluetooth device. • Put your soundbar into pairing mode, then refresh your list of Bluetooth devices. For more information, see the documentation that came with your Bluetooth device. • Make sure that your Bluetooth device is visible to other devices. For more information, see the documentation that came with your Bluetooth device.
Wireless subwoofer is not connected.	<ul style="list-style-type: none"> • The wireless subwoofer is set at the factory so that the soundbar and subwoofer should link automatically when the soundbar is turned on. However, if the link indicator does not light when the soundbar and subwoofer are both powered on or if your soundbar has been serviced recently, then you need to follow the procedure to set the ID and link. <ol style="list-style-type: none"> 1. Clear any obstacles between the soundbar and the subwoofer. 2. Using a small pointed object (paper clip) press the PAIR button on subwoofer until the LINK LED light blinks blue. 3. Using a small pointed object (paper clip) press the PAIR button on the soundbar until the LINK LED lights solid blue. The wireless subwoofer is connected to soundbar.

SPECIFICATIONS

Designs and specifications are subject to change without notice.

Dimensions (approx.)	Soundbar: 37.1 × 3.5 W × 2.5 in. (94.3 × 9.0 × 6.5 cm) Subwoofer: 11.9 H × 12.4 W × 8.1 in. (30.2 × 31.6 × 20.5 cm)
Weight	Soundbar: 4.0 lbs. (1.8 kg) Subwoofer: 7.7 lbs. (3.5 kg)
Power output	60 W total: left and right channel 15 W, subwoofer 30 W, 1% THD
Frequency response	150 Hz ~ 15 kHz

ONE-YEAR LIMITED WARRANTY

Visit www.insigniaproducts.com for details.

CONTACT INSIGNIA:

For customer service, call 1-877-467-4289 (U.S. and Canada) or 01-800-926-3000 (Mexico) www.insigniaproducts.com

INSIGNIA is a trademark of Best Buy and its affiliated companies.
Distributed by Best Buy Purchasing, LLC
©2015 Best Buy. All rights reserved.
Made in China