

# AVANTE

AS8 AC/DC ACTIVE LINE  
ARRAY PA SYSTEM

ELEVATING  
YOUR  
SOUND

USER  
MANUAL

©2023 **Avante Audio** all rights reserved. Information, specifications, diagrams, images, and instructions herein are subject to change without notice. Avante logo and identifying product names and numbers herein are trademarks of Avante Audio. Copyright protection claimed includes all forms and matters of copyrightable materials and information now allowed by statutory or judicial law or hereinafter granted. Product names used in this document may be trademarks or registered trademarks of their respective companies and are hereby acknowledged. All non-Avante brands and product names are trademarks or registered trademarks of their respective companies.

**Avante Audio** and all affiliated companies hereby disclaim any and all liabilities for property, equipment, building, and electrical damages, injuries to any persons, and direct or indirect economic loss associated with the use or reliance of any information contained within this document, and/or as a result of the improper, unsafe, insufficient and negligent assembly, installation, rigging, and operation of this product.

**AVANTE World Headquarters USA**

6122 S. Eastern Ave. | Los Angeles, CA 90040 USA  
323-316-9722 | Fax: 323-582-2941 | [www.avanteaudio.com](http://www.avanteaudio.com) | [info@avanteaudio.com](mailto:info@avanteaudio.com)

**AVANTE NETHERLANDS**

Junostraat 2 | 6468 EW Kerkrade | Netherlands  
+31 45 546 85 00 | Fax: +31 45 546 85 99 | [europa@avanteaudio.com](mailto:europa@avanteaudio.com)

**AVANTE MEXICO**

Santa Ana 30 | Parque Industrial Lerma | Lerma Mexico 52000  
+52 (728) 282.7070 | [ventas@avanteaudio.com](mailto:ventas@avanteaudio.com)

**Europe Energy Saving Notice**

Energy Saving Matters (EuP 2009/125/EC)

Saving electric energy is a key to help protecting the environment. Please turn off all electrical products when they are not in use. To avoid power consumption in idle mode, disconnect all electrical equipment from power when not in use. Thank you!

**Document Version:** An updated version of this document may be available online. Please check online at [www.avante.com](http://www.avante.com) for the latest revision/update of this document before beginning installation and use.

*The Bluetooth® word mark and logos are registered trademarks owned by Bluetooth SIG, Inc. and any use of such marks by Avante Audio is under license. Other trademarks and trade names are those of their respective owners.*

Date	Document Version	Notes
01/31/2023	1.0	Initial release

# CONTENTS

<b>FCC Statement</b>	<b>4</b>
<b>General Information</b>	<b>5</b>
<b>Limited Warranty (USA Only)</b>	<b>6</b>
<b>Safety Guidelines</b>	<b>7</b>
<b>Maintenance Guidelines</b>	<b>9</b>
<b>Overview</b>	<b>10</b>
<b>Connections &amp; Controls</b>	<b>11</b>
<b>Installation</b>	<b>14</b>
<b>Setup</b>	<b>15</b>
<b>Battery Information</b>	<b>17</b>
<b>Frequency Chart</b>	<b>19</b>
<b>Trouble Shooting</b>	<b>20</b>
<b>Dimensional Drawings</b>	<b>21</b>
<b>Technical Specifications</b>	<b>22</b>
<b>Components &amp; Accessories</b>	<b>23</b>

## **FCC STATEMENT**

This device complies with Part 15 of the FCC Rules. Operation is subject to the following two conditions: (1) this device may not cause harmful interference, and (2) this device must accept any interference received, including interference that may cause undesired operation.

### **FCC RADIO FREQUENCY INTERFERENCE WARNINGS & INSTRUCTIONS**

This product has been tested and found to comply with the limits as per Part 15 of the FCC Rules. These limits are designed to provide reasonable protection against harmful interference in a residential installation. This device uses and can radiate radio frequency energy and, if not installed and used in accordance with the included instructions, may cause harmful interference to radio communications. However, there is no guarantee that interference will not occur in a particular installation. If this device does cause harmful interference to radio or television reception, which can be determined by turning the device off and on, the user is encouraged to try to correct the interference by one or more of the following methods:

- Reorient or relocate the device.
- Increase the separation between the device and the receiver.
- Connect the device and the radio receiver to electrical outlets on separate electrical circuits.
- Consult the dealer or an experienced radio/TV technician for help.



# GENERAL INFORMATION

## INTRODUCTION

This speaker is designed for professional use only. Please read and understand all the instructions and guidelines in this manual carefully and thoroughly before attempting to operate these speakers. These instructions contain important information regarding safety, installation, and use.

## UNPACKING

Every speaker has been thoroughly tested and has been shipped in perfect operating condition. Carefully check the shipping carton for damage that may have occurred during shipping. If the carton appears to have been damaged, carefully inspect the speaker for damage and be sure all accessories necessary to install and operate the speaker have arrived intact. In the event that damage has been found or parts are missing, please contact our customer support team for further instructions. Please do not return this speaker to your dealer without first contacting customer support at the number listed below. Please do not discard the shipping carton in the trash. Please recycle whenever possible.

## CUSTOMER SUPPORT

AVANTE provides a customer support line to provide set up help, assist with any questions or problems that may arise during set up or initial installation, and for any service related issues. You may also visit us on the web at [www.avanteaudio.com](http://www.avanteaudio.com) for any comments or suggestions.

**AVANTE SERVICE USA – Monday – Friday 8:00am to 4:30pm PST**

**Voice: 800-322-6337**

**Fax: 323-532-2941**

[support@avanteaudio.com](mailto:support@avanteaudio.com)

**AVANTE SERVICE EUROPE - Monday - Friday 08:30 to 17:00 CET**

**Voice: +31 45 546 85 30**

**Fax: +31 45 546 85 96**

[europe@avanteaudio.com](mailto:europe@avanteaudio.com)



## WARRANTY REGISTRATION

Please register your product online: [www.avanteaudio.com](http://www.avanteaudio.com). Online product registration is required in order to activate the third year of the 3-year warranty. All returned service items, whether under warranty or not, must be freight pre-paid and accompanied by a return authorization (R.A.) number. The R.A. number must be clearly written on the outside of the return package. A brief description of the problem as well as the R.A. number must also be written down on a piece of paper and included in the shipping container. If the unit is under warranty, you must provide a copy of your proof of purchase invoice, and the unit must be registered online at [www.avanteaudio.com](http://www.avanteaudio.com) to receive year 3 of the 3-year warranty. Items returned without an R.A. number clearly marked on the outside of the package will be refused and returned at customer's expense. You may obtain an R.A. number by contacting customer support.

## LIMITED WARRANTY (USA ONLY)

1. ADJ Products, LLC hereby warrants, to the original purchaser, AVANTE products to be free of manufacturing defects in material and workmanship for a prescribed period of up to 3-years (1,095 days) from the original purchase date. Product must be registered online at [www.avanteaudio.com](http://www.avanteaudio.com) in order to activate year 3 of the 3-year warranty period. This warranty shall be valid only if the product is purchased within the United States of America, including possessions and territories. It is the owner's responsibility to establish the date and place of purchase by acceptable evidence at the time service is sought.
2. For warranty service you must obtain a Return Authorization number (RA#) before sending the product back; please contact ADJ Products, LLC Service Department at 800-322-6337. Send the product only to the ADJ Products, LLC factory. All shipping charges must be pre-paid. If the requested repairs or service (including parts replacement) are within the terms of this warranty, ADJ Products, LLC will pay return shipping charges only to a designated point within the United States. If the entire instrument is sent, it must be shipped in its original package. No accessories should be shipped with the product. If any accessories are shipped with the product, ADJ Products, LLC shall incur no liability whatsoever for loss of or damage to any such accessories, or for the safe return thereof.
3. This warranty is void if the serial number has been altered or removed; if the product is modified in any manner which ADJ Products, LLC concludes, after inspection, affects the reliability of the product; if the product has been repaired or serviced by anyone other than the ADJ Products, LLC factory unless prior written authorization was issued to purchaser by ADJ Products, LLC; if the product is damaged because it was not properly maintained as set forth in the instruction manual.
4. This is not a service contract, and this warranty does not include maintenance, cleaning or periodic check-up. During the period specified above, ADJ Products, LLC will replace defective parts at its expense with new or refurbished parts, and will absorb all expenses for warranty service and repair labor by reason of defects in material or workmanship. The sole responsibility of ADJ Products, LLC under this warranty shall be limited to the repair of the product, or replacement thereof, including parts, at the sole discretion of ADJ Products, LLC. All products covered by this warranty were manufactured after August 15, 2012, and bear identifying marks to that effect.
5. ADJ Products, LLC reserves the right to make changes in design and/or improvements upon its products without any obligation to include these changes in any products theretofore manufactured. No warranty, whether expressed or implied, is given or made with respect to any accessory supplied with products described above. Except to the extent prohibited by applicable law, all implied warranties made by ADJ Products, LLC in connection with this product, including warranties of merchantability or fitness, are limited in duration to the warranty period set forth above. And no warranties, whether expressed or implied, including warranties of merchantability or fitness, shall apply to this product after said period has expired. The consumer's and/or Dealer's sole remedy shall be such repair or replacement as is expressly provided above; and under no circumstances shall ADJ Products, LLC be liable for any loss or damage, direct or consequential, arising out of the use of, or inability to use, this product. This warranty is the only written warranty applicable to ADJ Products, LLC Products and supersedes all prior warranties and written descriptions of warranty terms and conditions heretofore published.
6. Warranty Registration: Please register your product online: [www.avanteaudio.com](http://www.avanteaudio.com). Online product registration is required in order to activate the third year of the 3-year warranty. All returned service items, whether under warranty or not, must be freight pre-paid and accompany a return authorization (R.A.) number. The R.A. number must be clearly written on the outside of the return package. A brief description of the problem as well as the R.A. number must also be written down on a piece of paper and included in the shipping container. If the unit is under warranty, you must provide a copy of your proof of purchase invoice and the unit must be registered online at [www.avanteaudio.com](http://www.avanteaudio.com) to receive year 3 of the 3-year warranty. Items returned without an R.A. number clearly marked on the outside of the package will be refused and returned at customer's expense. You may obtain an R.A. number by contacting customer support.

# SAFETY GUIDELINES

This speaker is a sophisticated piece of electronic equipment. To guarantee a smooth operation, it is important to follow all instructions and guidelines in this manual. AVANTE is not responsible for injury and/or damages resulting from the misuse of this speaker due to the disregard of the information printed in this manual. Only qualified and/or certified personnel should perform the installation of this speaker and all included and/or optional rigging accessories. Only the original included and/or optional rigging parts and accessories for this speaker should be used for proper installation. Any modifications to the speaker, included and/or optional rigging parts and accessories will void the original manufacturer's warranty and increase the risk of damage and/or personal injury.



## **PROTECTION CLASS 1 – SPEAKER MUST BE PROPERLY GROUNDED**



**TO REDUCE RISK OF ELECTRICAL SHOCK, DO NOT REMOVE ANY COVER. THERE ARE NO USER SERVICEABLE PARTS INSIDE THIS SPEAKER. DO NOT ATTEMPT ANY REPAIRS YOURSELF, AS DOING SO WILL VOID YOUR MANUFACTURER'S WARRANTY. DAMAGES RESULTING FROM MODIFICATIONS TO THIS SPEAKER AND/OR THE DISREGARD OF SAFETY INSTRUCTIONS AND GUIDELINES IN THIS MANUAL VOID THE MANUFACTURER'S WARRANTY AND ARE NOT SUBJECT TO ANY WARRANTY CLAIMS AND/OR REPAIRS. NEVER OPEN THIS SPEAKER WHILE IN USE! UNPLUG POWER BEFORE SERVICING SPEAKER! KEEP FLAMMABLE MATERIALS AWAY FROM SPEAKER!**



**DRY LOCATIONS USE ONLY!  
DO NOT EXPOSE SPEAKER TO RAIN AND/OR MOISTURE!  
DO NOT SPILL WATER AND/OR LIQUIDS ON OR INTO THE SPEAKER!**

# SAFETY GUIDELINES

***This speaker is for PROFESSIONAL USE ONLY! Read all INSTRUCTIONS and follow all WARNINGS!***

- DO NOT use speaker near wet and/or damp locations. Speaker must be kept away from direct contact with liquids and must not be exposed to water/liquid dripping or splashing.
- DO NOT attempt installation and/or operation without knowledge how to do so. Consult a professional sound equipment installer for proper and safe speaker installation. ONLY the original included, and/or optional rigging parts and accessories listed in this manual should be used for installation and operation.
- DO NOT expose any part of the speaker to open flame or smoke, or position speaker close to any flammable materials during operation. The speaker contains an internal power amplifier that produces heat during use. Keep speaker away from heat sources such as radiators, heat registers, stoves, or other appliances (including amplifiers) that produce heat.
- Be sure to install this speaker in an area that will allow proper ventilation. Allow approximately 6 inches (152mm) behind the speaker cabinet for proper cooling.
- DO NOT operate speaker if power cord is frayed, crimped, damaged, and/or if any of the power cord connectors are damaged and do not insert into the speaker securely with ease. NEVER force a power cord connector into the speaker. If the power cord or any of its connectors are damaged, replace it immediately with a new one of the same power rating.
- DO NOT disassemble speaker, as there are NO user serviceable parts inside. Refer all servicing to qualified service personnel. Servicing is required when the speaker has been damaged in any way, such as damage to the power-supply cord or plug, exposure to liquid, rain, or moisture, objects falling onto the speaker or dropping of the speaker itself, or any abnormal operation.
- DO NOT defeat the safety purpose of the polarized or grounding-type plug. A polarized plug has two blades with one wider than the other. A grounding type plug has two blades and a third grounding prong. The wide blade or the third prong is provided for your safety. If the provided plug does not fit into your outlet, consult an electrician for replacement of the obsolete outlet.
- POWER SOURCES: This product must be connected only to a power supply of the type described in these operating instructions, or as marked on the unit. This product is Country Specific.
- PROTECTIVE EARTHING TERMINAL: The speaker should be connected to a main socket outlet with a protective earth-ground/earthing connection.
- ONLY handle power cord by the plug end, and never pull the plug out by tugging the wire portion of the cord.
- DO NOT use solvents or glass cleaner to clean speaker. Clean only with a dry cloth.
- ALWAYS disconnect speaker from main power source before performing any servicing or cleaning procedure.
- CAUTION: To avoid physical damage, read the installation instructions carefully before installation.
- CAUTION: Listening to speakers at high volume for extended time or within immediate proximity may damage hearing.
- CAUTION: Speakers should be installed/operated by qualified and trained professionals ONLY.
- CAUTION: Always mount speakers in a safe and stable manner.
- CAUTION: Wear appropriate safety equipment during speaker installation.
- CAUTION: Route power and audio cables so that they are NOT likely to be walked on or pinched.
- CAUTION: Unplug the speaker during lightning storms and/or when unused for long periods of time.
- ONLY use the original packaging materials and/or case to transport the speaker in for service.
- PLEASE recycle shipping boxes and packaging whenever possible.



# MAINTENANCE GUIDELINES

Regular maintenance is necessary to optimize the potential functional lifespan of the speakers.

- Read the installation and operation instructions in order to familiarize yourself with the correct operation of the speakers.
- Although the speakers are rugged and designed to withstand limited impact forces when installed correctly, care should still be taken to avoid impact damage when handling or transporting speakers, especially the speaker mesh screen.
- The speakers should be serviced by a qualified service technician when:
  - A. Objects have fallen onto, or liquid has been spilled into, the speaker.
  - B. Been exposed to rain or water.
  - C. Does not appear to operate normally or exhibits a marked change in performance.
  - D. Has fallen and/or been subjected to extreme handling.
- Check each speaker for loose screws and/or other fasteners.
- If the speaker is installed or mounted for an extended period of time, all rigging and installation equipment should be regularly inspected, and should be replaced or repaired as necessary. Main power to the unit should be disconnected during long periods of non-use.
- If a breaker-switch trips, wires burn, and or any other abnormalities occur while conducting an electrical test a circuit shorts, discontinue testing immediately. Troubleshoot the problematic unit(s) to find the problem before continuing with any testing or operation.
- The speakers are designed for use in dry locations only.
- When not in use, store speakers in a dry, well ventilated storage location.

# OVERVIEW

## INCLUDED ITEMS

- Active subwoofer with built in mixer, 8" driver (x1)
- Speaker Column - speaker array with six (6) 2.75" drivers (x1)
- Riser/Support Column (x1)
- IEC Power Cable (x1)
- Travel Bag (x1)



# CONNECTIONS & CONTROLS

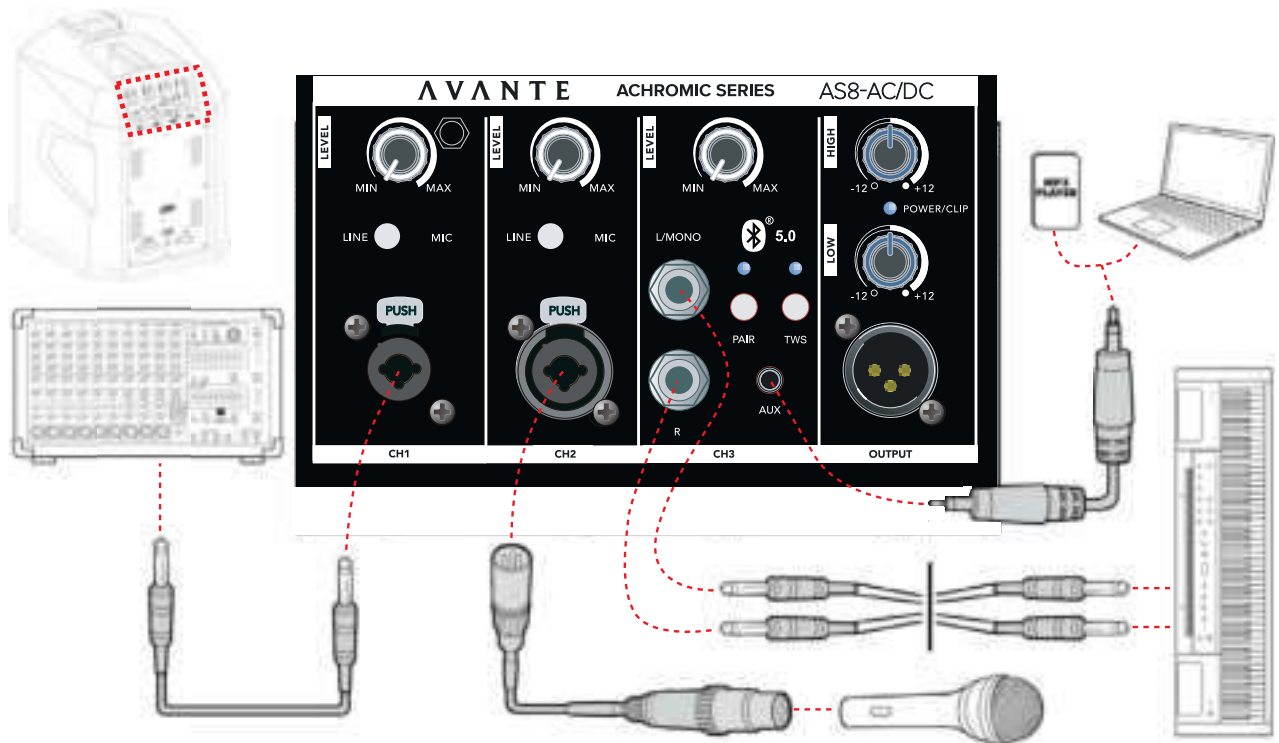

## MAKING CONNECTIONS

- Plug connection to INPUT 1 (CH1) – check that the MIC/LINE switch matches the source (Mic for microphones and instruments, Line for mixers, keyboards, or instruments with active pickups).
- Plug connection to INPUT 2 (CH2) – proceed in the same manner as with INPUT 1.
- Plug connection to INPUT 3 (CH3) – STEREO jack is well suited to use with mobile phone, mobile audio device, or computer.
- 10dB LINE jacks is well suited for use with keyboard, drum machine, or other line level devices. See **Bluetooth® Controls** section to use a wireless device as the source for INPUT 3.

## POWERING UP

- Turn on the power to any devices plugged into Input 1 (CH1), Input 2 (CH2), or Aux Input (CH3) and ensure their output volumes are turned up. (Generally, the best sound can be achieved by turning output device volume to maximum, then making any volume adjustment via the input gain controls of the AS8 AC/DC).
- Power ON the AS8 AC/DC.
- Slowly turn INPUT 1 (CH1) GAIN, INPUT 2 (CH2) GAIN, and INPUT 3 (CH3) GAIN to the desired levels.

## POWER/CLIP LED AND PROPER LEVELS

- This LED on the AS8 AC/DC should normally be green when its AC power cord is connected to an electrical outlet, and the Power Switch is turned on.
- If this LED is constantly turning red, it means that one of the input signals is too high.
- Turn down each input gain volume knob in turn to find which is distorting, and set that knob to clipping.

## FLOOR MONITOR APPLICATIONS

- Turn the LOW Equalizer knob down slightly to reduce unwanted rumble and low-frequency build-up. This will reduce feedback and make vocals clearer.
- Power ON the AS8 AC/DC. Slowly turn INPUT 1 GAIN, INPUT 2 GAIN, and INPUT 3 GAIN to the desired levels.

## LINKING MULTIPLE SPEAKERS

- If linking multiple speakers, connect all input sources to the first AS8 AC/DC to the LINE IN connection of the next AS8 AC/DC, and continue the daisy chain to the last AS8 AC/DC. (This is common where multiple monitor mixers share the same feed from the mixing board.)
- To avoid “pops” when turning power on/off, the last AS8 AC/DC should be powered on last, and powered off first.

# CONNECTIONS & CONTROLS

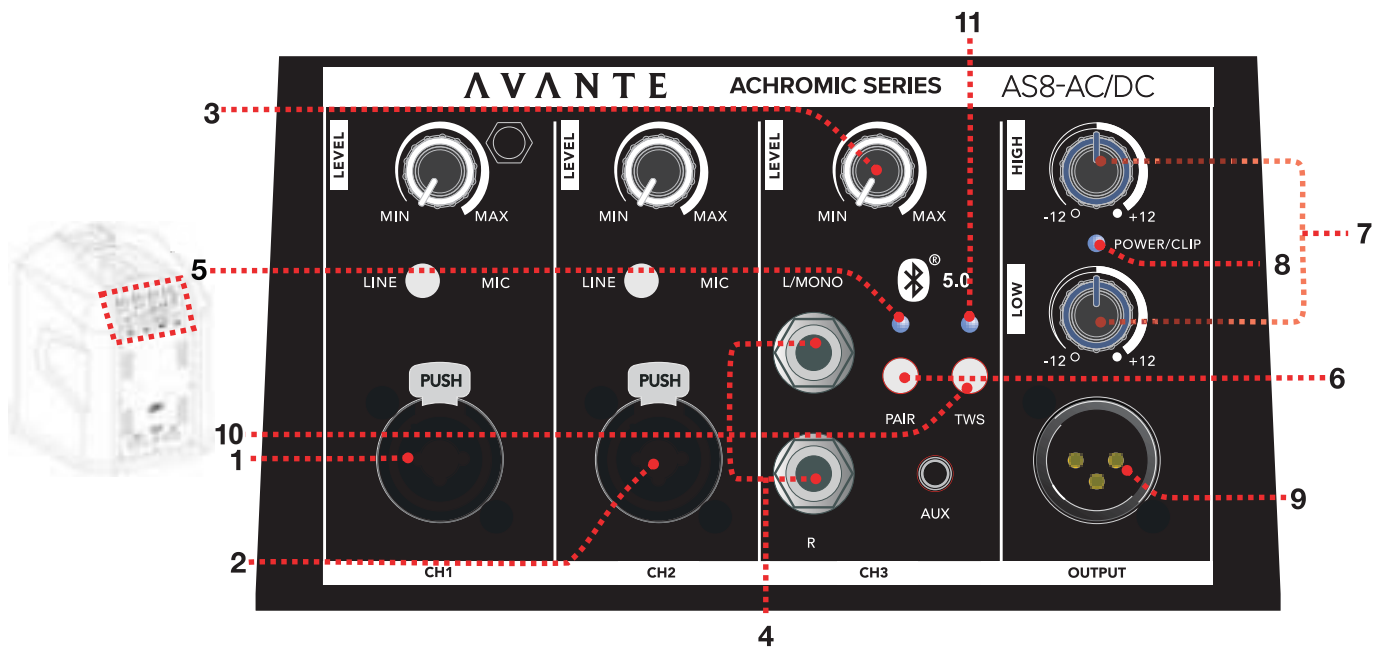

1. **CHANNEL 1:** This input accepts balanced XLR plugs, and balanced/unbalanced TRS (tip/ring/sleeve) 1/4" plugs. Set the LINE/MIC switch to match the type of device that will be connected in order to prevent distortion. When using an unbalanced 1/4" instrument jack, start with the button in LINE setting. Then, if the gain is too low, turn the volume down, select MIC, and slowly raise the volume.
2. **CHANNEL 2:** This input accepts balanced XLR plugs, and balanced/unbalanced TRS (tip/ring/sleeve) 1/4" plugs. Set the GTR/MIC switch to match the type of device that will be connected to prevent distortion. When using an unbalanced 1/4" instrument jack, start with the button in GTR setting. Then, if the gain is too low, turn the volume down, select MIC, and slowly raise the volume.
3. **CHANNEL 3 LEVEL KNOB:** This knob sets the volume for Channel 3.
4. **CHANNEL 3 AUX JACKS:** The small 1/8" jack is for connecting a portable audio device like a phone, a computer, MP3, or CD player. The L (left) and R (right) jacks can be used for -10dB line level devices like keyboards or drum machines. For best results, do not use the 1/8" and L/R jacks simultaneously.
5. **CHANNEL 3 BT:** Bluetooth® (BT).
6. **CHANNEL 3 BLUETOOTH® CONTROLS:** To use a Bluetooth-enabled device like your phone or computer as the source for Input 3, you must first "pair" it with your AS8 AC/DC. Refer to the **Setup** section of this manual for detailed instructions.
7. **LOW AND HIGH EQ KNOBS:** The LOW knob will provide +/- 12dB of boost or cut below 100Hz. Turn LOW up to add bass or warmth to the speaker. Turn LOW down to remove rumble and noise when the program material does not contain low frequencies, or when using the speaker as a floor monitor. The HIGH knob will provide +/-12dB of boost, or cut above 10kHz. Turn HIGH up to add clarity and definition to vocals, acoustic instruments, or backing tracks. Turn HIGH down to reduce hiss or feedback.
8. **POWER/CLIP LED:** The green LED on the AS8 AC/DC indicates that AC power cord is connected to an electrical outlet, and the Power Switch is turned on. If you see the red LED while audio is playing into the speaker, this indicates that the speaker is being overdriven, and the limiter is engaged. If the CLIP LED is constantly lit, first reduce the Gain on the Input channels.
9. **LINE OUT 0.0dB:** The LINE OUT provides a 0.0dB level signal and is used to link multiple AS8 AC/DC units together using the same audio signal. Connect the LINE OUT of the first AS8 AC/DC to a Line Input of the next AS8 AC/DC in the signal path.
10. **TWS BUTTON:** Refer to the **Setup** section of this manual for detailed instructions.
11. **TWS LED**

# CONNECTIONS & CONTROLS

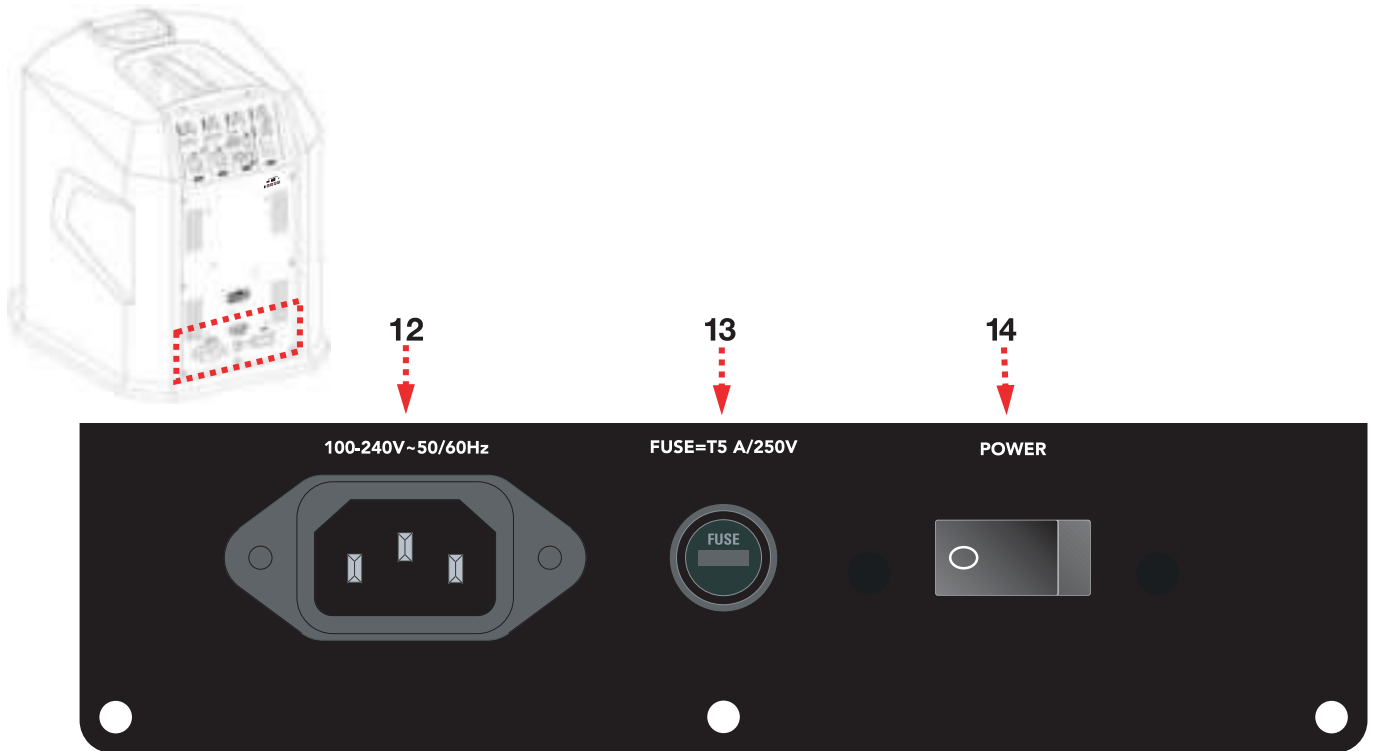

**12. IEC POWER INPUT:** The IEC power cable plug inserts into this jack.

**13. FUSE:** The power must be turned off and device disconnected from the power source before replacing the fuse. Only use a fuse with the same power rating, which is specified on rear panel.

**14. POWER:** Turns the AS8 AC/DC power ON or OFF.

# INSTALLATION



**DO NOT INSTALL SPEAKERS IF YOU ARE NOT QUALIFIED TO DO SO!  
INSTALLATION BY QUALIFIED TECHNICIANS ONLY**



**INSTALLATIONS SHOULD BE CHECKED BY A QUALIFIED PERSON ONCE A YEAR!**



## **FLAMMABLE MATERIAL WARNING**

**Keep speaker a minimum of 5.0 feet (1.5m) away from flammable materials and/or pyrotechnics.**



## **ELECTRICAL CONNECTIONS**

**A qualified electrician should complete all electrical connections and/or installations.**



**USE CAUTION WHEN POWER LINKING MULTIPLE SPEAKERS AS THE POWER CONSUMPTION OF OTHER SPEAKER MODELS MAY EXCEED THE MAX POWER OUTPUT ON THIS SPEAKER. CHECK SILK SCREEN ON SPEAKER FOR MAX AMPS.**

**WARNING!** The safety and suitability of any lifting equipment, installation location/platform, anchoring/rigging/mounting method, hardware, and electrical installation is the sole responsibility of the installer.

Install speaker(s), all speaker accessories, and all anchoring/rigging/mounting hardware following all local, national, and country commercial, electrical, and construction codes and regulations.

Install speakers(s) in areas outside walking paths, seating areas, and or any location where they may be within reach of the general public.

Take all appropriate precautions and safety measures when placing equipment in potentially dangerous locations, especially where public safety is a concern.

# SETUP

## ASSEMBLY

1. Position the device in the desired location, and ensure that the speaker is mounted in a secure, stable manner.
2. Make sure the POWER switch is OFF.
3. Make certain INPUT GAIN 1, INPUT GAIN 2, and MASTER VOLUME are down.
4. Set EQUALIZER knobs to center (12 o'clock).
5. Insert the Riser/Support Column into the sub.
6. Insert the Speaker Column into the Riser/Support Column.

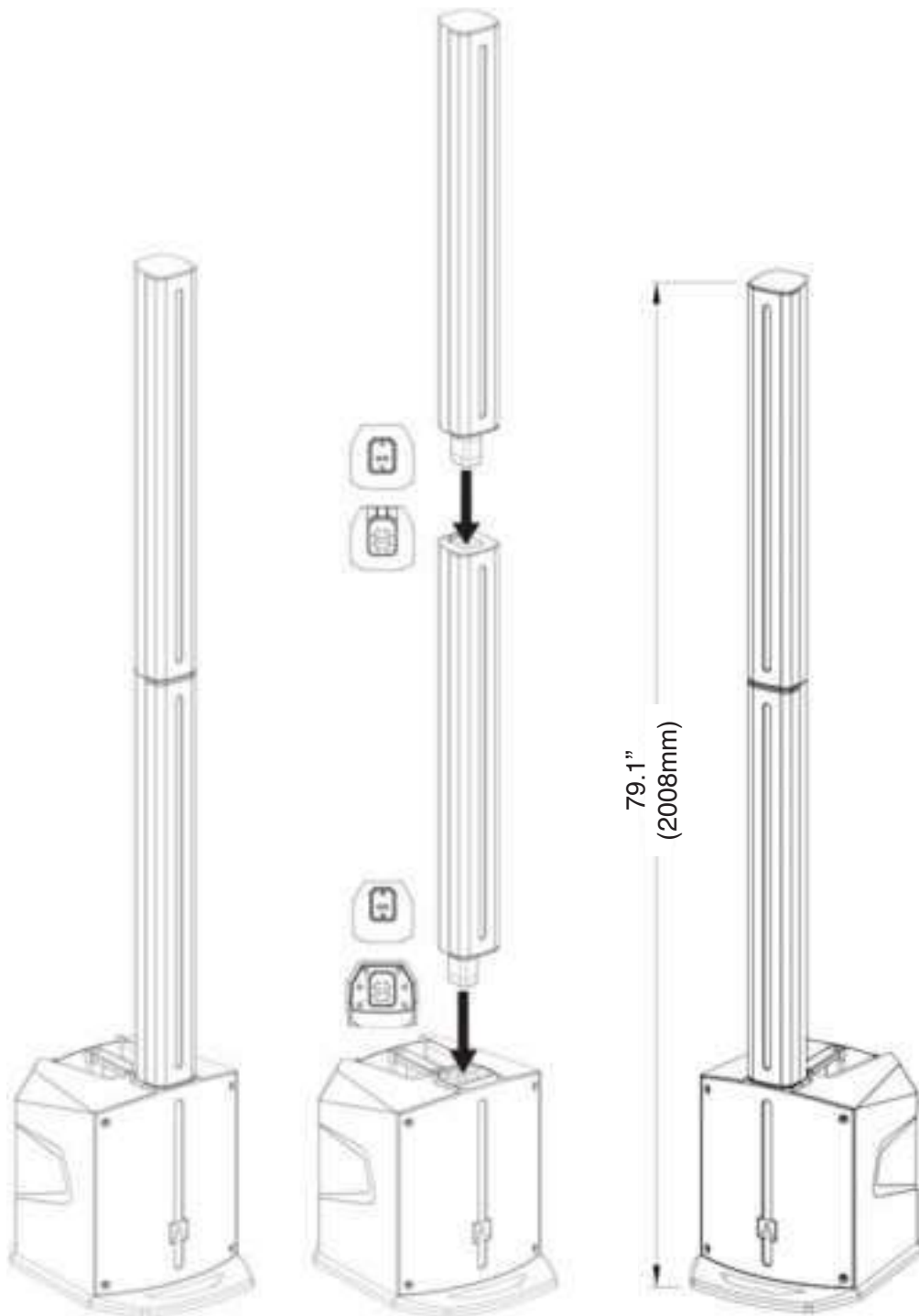

# SETUP

**BLUETOOTH CONNECTION:** To use a Bluetooth-enabled device like your phone or computer as the source for Input 3, you must first “pair” it with your AS8 AC/DC.

1. Power on your AS8 AC/DC and enable Bluetooth on your source device (phone, computer, or other mobile device).
2. From your source device, display its list of discovered Bluetooth devices and look for “AVANTE AS8 AC/DC” there. If your device is unable to find the speaker, try scrolling down the list to make sure it’s not hidden off-screen. If it’s not listed, push and release the PAIR/play/pause button on your AS8 AC/DC.
3. Once “AVANTE AS8 AC/DC” appears on the list, select it. Your source device and your AS8 AC/DC will pair, and the AS8 AC/DC will chime and illuminate the Bluetooth LED to indicate that the connection was successful.
4. Play audio from your Bluetooth source device, and it will now play via INPUT 3 of your AS8 AC/DC as the Bluetooth LED slowly flashes.
5. Pressing the PAIR/play/pause button will now remotely control the play/pause action of your device, with the Bluetooth LED flashing during play, and solid while paused.
6. To “disconnect” your Bluetooth device from Input 3, press and hold the PAIR/play/pause button. The LED will turn off and you will hear a chime.
7. When you power on your AS8 AC/DC, it will look for any previously paired device, and pair with it automatically if available.

## TWS INSTRUCTIONS:

1. Power on speakers, and press the PAIR button to pair each speaker. The speakers do NOT have to be paired in any particular order, and both should be available for pairing.
2. Use the TWS button on each speaker to determine which speaker is the primary (left channel) and which is the secondary speaker (right channel). The speaker whose TWS button is pressed first will be set as primary speaker. When TWS lights of the two speakers flash, the TWS features of these two speakers will be connected, and the PAIR light of the secondary speaker will automatically turn off. The secondary speaker will not be available for pairing.
3. Enable Bluetooth on your mobile phone, search for the primary speaker and connect with it.

### Notes:

- Press the PAIR button to turn on Bluetooth. If the PAIR indicator blinks, the speaker is now in pairing mode. If the speaker is not connected to any devices (including the TWS connection) within 5 minutes, the PAIR indicator switch off and the speaker will automatically exit pairing mode. When you use speaker in single mode, if its TWS button is pressed, the TWS light will blink for 2 minutes then will automatically switch off, which will not affect the speaker’s ability to operate in single mode.
- In single speaker mode, the outputs of the L+R channels will be mixed. When you connect two speakers with TWS, the primary speaker is the left channel and the secondary speaker is the right channel.
- To exit TWS mode, press the TWS button on either speaker. The secondary speaker will be released and enter pairing mode.
- If the TWS connection is not disconnected by pressing the TWS button, the two speakers’ TWS will be automatically connected after pressing the PAIR button when speaker power on.
- If two speakers are connected with TWS, you can press the PAIR button on either speaker to turn off their Bluetooth at the same time.



# BATTERY INFORMATION

## HANDLING PRECAUTIONS

**Do not short circuit the battery.** Avoid subjecting the battery to a short circuit, as doing so generates a very high current, resulting in overheating, electrolyte gel leakage, harmful fumes, explosion risk, or other damage to the battery.

**Mechanical shock.** Dropping, impacting, striking, or bending the unit, or subjecting the unit to any other types of mechanical shock may cause failure or shorten life of the battery.

**Do not disassemble the batteries.** Never disassemble the batteries, as doing so may result in an internal short circuit in the battery, leading to fire, explosion, release of harmful fumes, or other hazards. Electrolyte gel is harmful, and contact should be avoided whenever possible. Should the electrolyte gel come into contact with the skin or eyes, flush the area of contact immediately with fresh water and seek medical attention immediately.

**Do not expose battery to heat or fire.** Never incinerate or dispose of the batteries in fire, as this could result in an explosion.

**Do not expose the battery to water or liquids.** Never expose or immerse the batteries in liquids of any type, including water, seawater, soft drinks, juices, coffee, or other beverages.

**Battery Replacement.** For battery replacement please contact customer support.

**Never use a damaged battery.** Shipping carries a risk of damage to the battery. Should damage be observed, including damage to the plastic casing of the battery, deformation of the battery package, chemical or electrolyte odor, or leakage of the electrolyte gel, or any other miscellaneous damage, **DO NOT use the battery.** A battery with a odor of electrolyte or a gel leakage should be placed away from fire to avoid risk of fire or explosion.

**Battery Storage.** The battery should be stored at room temperature, with a charge of at least 50%. During long periods of storage, it is recommended that the battery be charged every 6 months. Doing so will prolong the life of the battery and will also make sure that the battery charge does not fall below the 30% mark.

**Other Chemical Reactions.** Because batteries rely on a chemical reaction to work, battery performance will deteriorate over time, even if stored for a long period of time without being used. In addition, if various usage conditions (such as charge, discharge, ambient temperature, etc.) are not maintained within the specified ranges, the life expectancy of the battery maybe shortened or the device in which the battery is used may be damaged by electrolyte gel leakage. If the batteries cannot maintain a charge for long periods of time, even when they are charged correctly, this may indicate the need to replace the battery.

**Battery Disposal.** Please dispose of battery according to local regulations.

# BATTERY INFORMATION

## BATTERY STATUS DURING OPERATION:

- Four (4) steady indicator lights = 75% to 100% charge
- Three (3) steady indicator lights = 51% to 74% charge
- Two (2) steady indicator lights = 26% to 50% charge
- One (1) steady indicator light = 11% to 25% charge
- One (1) blinking indicator light = 10% charge or less

## BATTERY STATUS DURING CHARGING:

- Four (4) steady indicator lights = 91% to 100% charge
- Three (3) steady indicator lights + one (1) blinking indicator light = 71% to 90% charge
- Two (2) steady indicator lights + two (2) blinking indicator lights = 46% to 70% charge
- One (1) steady indicator light + three (3) blinking indicator lights = 21% to 45% charge
- Four (4) blinking indicator lights = 20% charge or less

## BATTERY RECHARGING:

To recharge the battery, plug one end of the supplied AC cord into the AC input on the side of the unit, and the other end into a matching power supply. **It is recommended to disconnect the unit from the charger once the battery has reached full charge.** Doing so reduces the risk of over-charging the battery, which can shorten the service life of the battery.

*NOTE:* When unplugging the unit from charging and then applying power via battery, there will be a small charge drop.

# FREQUENCY CHART

## SPL vs Freq

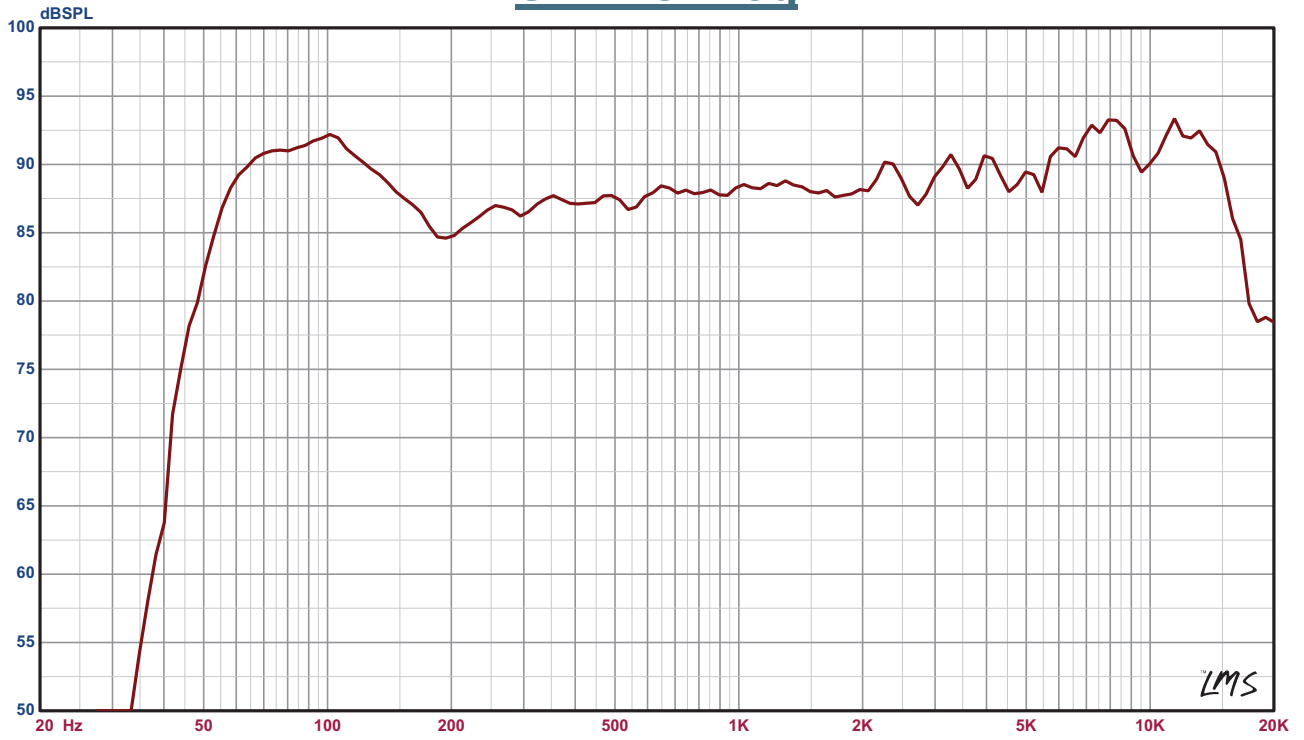

# TROUBLE SHOOTING

## ***Mixer and amplifier will not turn on.***

Check whether the included power cord is securely plugged in to a working power outlet.

## ***Amplifier turns off suddenly.***

Check whether any of the device's vents are blocked. Since inadequate ventilation will cause the device to overheat, turn off the mixer and uncover the vents to allow the product and its internal amplifier to cool. After a few minutes, the product should reset itself and can return to normal playback.

## ***The POWER/CLIP LED is flashing continuously.***

If the POWER/CLIP LED is flashing, the amplifier is being used beyond its design capabilities. Turn off and on and resume playback.

## ***No sound from the speaker(s).***

Check that the external instruments and/or microphones are connected correctly to inputs, that those sources are powered on, and that all cabling is functional. Check that the input gain controls of all active inputs are set appropriately. If using Bluetooth®, ensure that the AUX/BLUETOOTH switch set is to Bluetooth, that your source device and AS8 AC/DC have successfully paired, and that your source device is still active (not asleep or out of battery power) and audio with its output level control is set to an audible level.

## ***Distortion/noise in the audio signal, or low output level.***

You will generally get the lowest noise (hiss) by setting source device output to max, and then making any reductions of the volume via the AS8 AC/DC input gain knobs. Check that the output levels of any source devices are set appropriately, and that the INPUT GAIN controls for all inputs are set to appropriate levels. Check that the MIC/LINE switches of each input are set appropriately, as well. Check whether both the STEREO jack and the -10dB LINE IN jacks on INPUT 3 are being used (connected) at the same time. If the POWER/CLIP LED is lighting, try adjusting each INPUT GAIN knob in turn to find which is the source of clipping.

## ***Sound level is too loud during voice announcements.***

Check whether the INPUT GAIN level for the mic input is set too high, or whether the levels for your other inputs are set too low, either on the source device(s), or at their INPUT GAIN controls.

## ***Out of the effective Bluetooth® audio range of the device.***

Effective line-of-sight range is up to 50 feet. The wireless performance of the device is significantly affected by walls or metal, interference by WiFi, or other wireless devices.

# DIMENSIONAL DRAWINGS

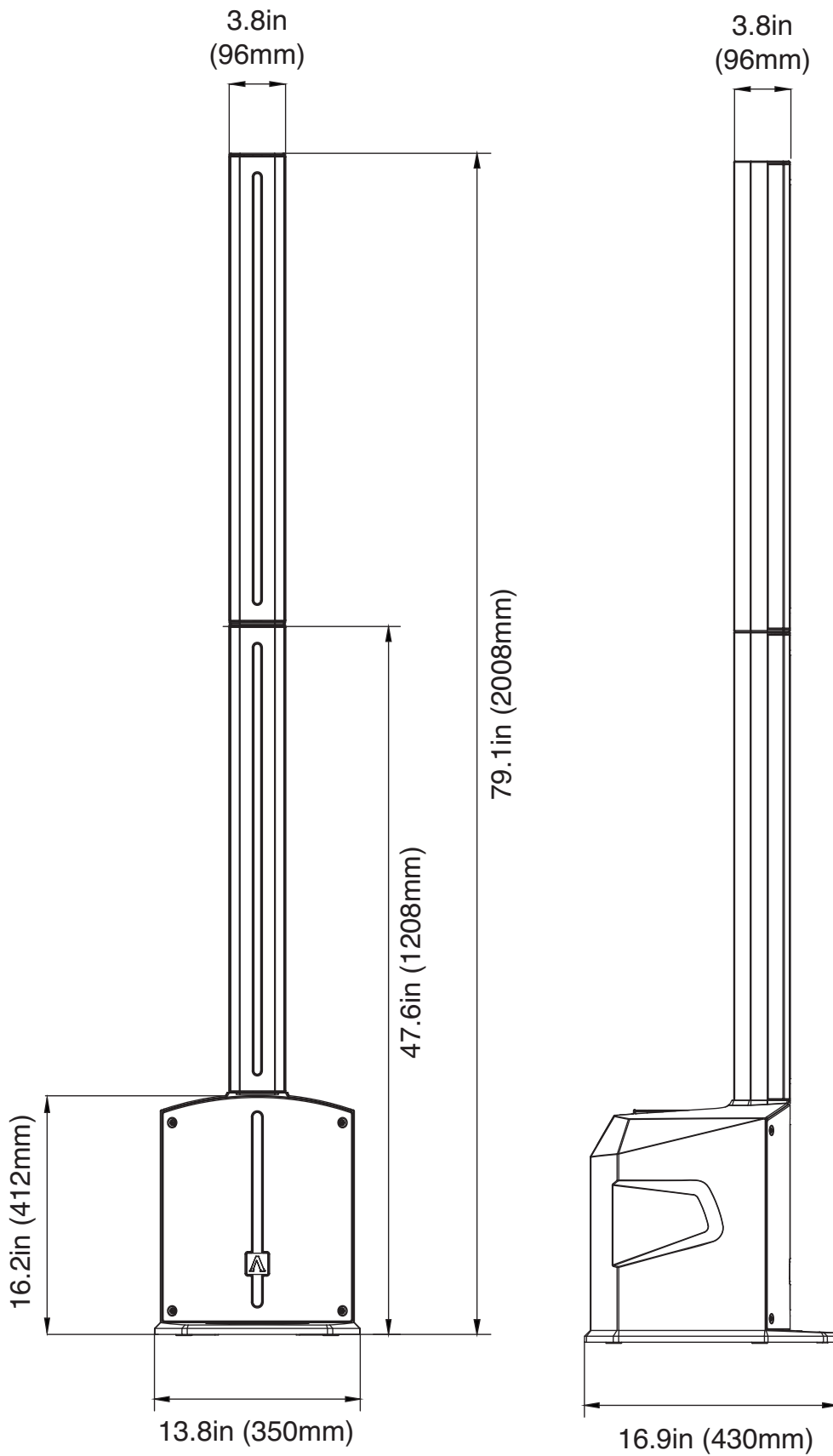

# TECHNICAL SPECIFICATIONS

## AMPLIFIER:

Inputs: Two XLR/TRS combo jacks, Stereo 1/4" inputs, Stereo 1/8" input, Bluetooth®

Outputs: XLR balanced line output

Power output: RMS 250W (SUB) RMS, 800W peak

Volume: Input Gain control per channel

EQ: Main out 2 band EQ

LEDs: Power/Clip indicator

Power Input: 100-240V~50/60Hz switchable 250W

Amplifier: Class D amplifier with switching power design

## ACTIVE VENTED SUBWOOFER:

Frequency Response: 55-200Hz

Max Output SPL: 116dB (at max. amp output)

Impedance: 4 Ohm

Driver: 8-inch neodymium subwoofer, 1.5" voice coil, 28 oz. magnet

Cabinet: PP plastic

Grill: 1.0mm steel

Dimensions: 16.9" x 13.8" x 16.2" / 430mm x 350mm x 412mm

Weight: 31.5 lbs / 14.3 kg

## PASSIVE FULL-RANGE SPEAKER COLUMN:

Frequency Response: 180-20kHz

Max. output SPL: 110dB

Impedance: 4 Ohm

Driver: 6x 2.75-inch full range line array

Cabinet: ABS plastic

Grill: 1.0mm steel

Dimensions: 3.8" x 3.8" x 31.4" / 96mm x 96mm x 796mm

Weight: 14.2 lbs / 6.45 kg

## BATTERY:

Nominal Value: 28.8V, 5000 mAh (8 x 2 cell) lithium battery pack

Capacity: 144 Wh

Size: 7.3" x 5.6" x 0.8" / 186mm x 143mm x 21.5mm

Weight: 2.2 lbs / 980 g

Max Charging Voltage: 33.6 V

Charging Current: 1.5 A

Charging Power: 45 W

## CERTIFICATIONS:

FCC, CE, & ETL



## COMPONENTS & ACCESSORIES

SKU	DESCRIPTION
WM219	WM-219 Wireless Microphone System
WM419	WM-419 Wireless Microphone System
VPS564	VPS-80 Microphone
VPS916	VPS-60 Microphone
VPS205	VPS-20 Microphone
PWR571	Pow-R Bar65

This device complies with Part 15 of the FCC Rules. Operation is subject to the following two conditions: (1) this device may not cause harmful interference, and (2) this device must accept any interference received, including interference that may cause undesired operation

NOTE: This equipment has been tested and found to comply with the limits for a Class B digital device, pursuant to Part 15 of the FCC Rules. These limits are designed to provide reasonable protection against harmful interference in a residential installation. This equipment generates, uses and can radiate radio frequency energy and, if not installed and used in accordance with the instructions, may cause harmful interference to radio communications. However, there is no guarantee that interference will not occur in a particular installation.

If this equipment does cause harmful interference to radio or television reception, which can be determined by turning the equipment off and on, the user is encouraged to try to correct the interference by one or more of the following measures:

- Reorient or relocate the receiving antenna.
- Increase the separation between the equipment and receiver.
- Connect the equipment into an outlet on a circuit different from that to which the receiver is connected.
- Consult the dealer or an experienced radio/TV technician for help.

Warning: changes or modifications not expressly approved by the party responsible for compliance could void the user's authority to operate the equipment

The device has been evaluated to meet general RF exposure requirement, the device can be used in an uncontrolled environment without restriction.