

Cuisinart®

INSTRUCTION
BOOKLET



Cuisinart® SmartPower Duet® Blender/Food Processor

BFP-703 Series

For your safety and continued enjoyment of this product, always read the instruction book carefully before using.

IMPORTANT SAFEGUARDS

When using an electrical appliance, basic safety precautions should always be followed, including the following:

1. **READ ALL INSTRUCTIONS BEFORE USING.**

2. To protect against the risk of electrical shock, do not put motor base of SmartPower Duet® appliance in water or other liquid.
3. This appliance is not intended for use by children or by persons with reduced physical, sensory, or mental capabilities, or lack of experience and knowledge. Close supervision is necessary when any appliance is used near children. Children should be supervised to ensure that they do not play with the appliance.
4. Turn the appliance OFF, then unplug from the outlet when not in use, before assembling or disassembling parts and before cleaning. To unplug, grasp the plug and pull from the outlet. Never pull from the power cord.

WARNING: Never put hands into the blender jar/food processor work bowl or container, or handle the blades with appliance plugged in.

5. Avoid contact with moving parts.
6. Do not operate any appliance with a damaged cord or plug or after the appliance malfunctions, or is dropped or damaged in any manner. Contact the manufacturer at their customer service telephone number for information on examination, repair, or adjustment
7. The use of attachments, other than those recommended by Cuisinart, including canning or ordinary jars not recommended or sold by Cuisinart, may cause fire, electrical shock, or risk of injury to persons.
8. Do not use outdoors.
9. Do not let cord hang over edge of counter or table or touch hot surfaces, which could damage the cord.
10. Keep hands and utensils out of jar/food processor work bowl during use, to reduce the risk of severe injury to persons or damage to blender itself. A rubber or plastic spatula may be used but must be used only when the blender is turned OFF.
11. When motor base is in ON mode, and LED lights are flashing or glowing, do not touch cutting assembly, interfere with blade movement or remove blender jar cover. Accidentally touching a speed button may activate the blender.
12. **BLADES ARE VERY SHARP. HANDLE CAREFULLY.** Store out of reach of children.
13. To reduce the risk of injury, never place chopping blade/cutting assembly on base unless the blender jar or food processor work bowl is properly attached.

14. Always operate blender or food processor with the cover in place.
15. Never leave your blender or food processor unattended while running.
16. When blending HOT liquids in blender jar, remove measured pour lid (center piece of cover) to allow steam to escape.
17. Twist on locking ring firmly. Injury can result if moving blades accidentally become exposed.
18. Do not use an extension cord with this unit. Doing so may result in fire, electrical shock, or personal injury.
19. Regarding your cord set: A longer cord has been provided so that you will have flexibility in positioning your Cuisinart® SmartPower Duet® Blender/Food Processor near an electrical outlet. Exercise care when using the longer cord to avoid entangling or tripping over the cord. The longer cord should be arranged so that it will not drape over the counter or tabletop, where it can be pulled on by children or tripped over. Excess cord should be stored in the cord storage area at the back of the blender base, to avoid injury caused by the longer cord.
20. Be certain the food processor cover is securely locked in place before operating appliance. Never operate without the cover locked securely in place.
21. Do not attempt to defeat the food processor cover interlock mechanism.
22. Never feed food into processor by hand. Always use the food pusher.
23. Make sure the blade or disc has come to a full stop before removing cover.
24. This food processor attachment is to be used only with Cuisinart® BFP-703 series blenders. Do not use with any other manufacturer's blender base. This appliance is intended for household use only.
25. Wash the blender jar, food processor work bowl, food processor chopping blade, locking ring, and covers before first use.
26. **WARNING: TO REDUCE THE RISK OF ELECTRICAL SHOCK OR FIRE, DO NOT REMOVE THE BASE PANEL. NO USER SERVICEABLE PARTS ARE INSIDE. REPAIR SHOULD BE DONE ONLY BY AUTHORIZED PERSONNEL.**
27. Do not operate your appliance in an appliance garage or under a wall cabinet. **When storing in an appliance garage always unplug the unit from the electrical outlet.** Not doing so could create a risk of fire, especially if the appliance touches the walls of the garage or the door touches the unit as it closes.

NOTICE: Do not fill the bowl above the marked maximum fill line (or rated capacity) to avoid risk of injury due to damage to the cover or bowl.

SAVE THESE INSTRUCTIONS FOR HOUSEHOLD USE ONLY

NOTICE

This appliance has a polarized plug (one prong is wider than the other).

To reduce the risk of electric shock, this plug will fit into a polarized outlet only one way. If the plug does not fit fully into the outlet, reverse the plug.

If it still does not fit, contact a qualified electrician. Do not modify the plug in any way.

Maximum rating of 500 watts is based on the jar attachment that draws the greatest power. Other recommended attachments may draw significantly less power.

This unit comes with a resettable thermal fuse to prevent damage to the motor in the case of extreme overload. Simply unplug the unit, rest it for 15 minutes and continue.

UNPACKING INSTRUCTIONS

Place the gift box containing your Cuisinart® SmartPower Duet® Blender/Food Processor on a flat, sturdy surface before unpacking. Remove instruction booklet and other printed materials from top of corrugated insert. Next, remove the top corrugated insert. It contains the measured pour lid, adapter stem, and the slicing/shredding disc. Carefully remove slicing/shredding disc, as it is VERY SHARP, then remove lid and adapter stem.

Carefully lift blender base from box and set aside. Remove food processor accessory. Remove the lower corrugated insert containing the blender jar assembly. Be careful not to tip the jar when removing. Remove any additional literature from the box.

To assemble the blender, follow Assembly instructions on page 5 of this instruction booklet. Replace all corrugated inserts in the box and save the box for repackaging. See the Features and Benefits section of this booklet for a listing of all blender parts.

Before using for the first time: Wash all parts according to the Cleaning and Maintenance section on page 7 of this booklet to remove any dust or residue.

CONTENTS

Important Safeguards	2
Unpacking Instructions	3
Introduction	3
Blender	
Blender Features and Benefits	4
Blender Assembly, Use and Care	5
Blender Operation	5
Blender Quick Reference Guides	7
Cleaning and Maintenance	7
Do's and Don'ts	8
Food Processor	
Food Processor Features	9
Food Processor Assembly, Use and Care	10
Food Processor Operation	10
Recipe Tips	12
Cleaning and Storing	13
Guidelines for Preparing Foods for Slicing & Shredding	14
Recipes	13
Warranty Information	29

INTRODUCTION

Congratulations! You have purchased two of Cuisinart's most versatile appliances wrapped into one! The Cuisinart® SmartPower Duet® Blender/Food Processor combines Cuisinart's top-of-the-line 7-Speed Electronic Blender with our legendary Cuisinart® Food Processor.

As a blender, the The Cuisinart® SmartPower Duet® Blender/Food Processor is the life of the party, engineered with seven speeds that let you purée, blend, mix, stir and more. One speed is just for crushing ice, though ice can be crushed perfectly at any of the settings. You can make soups, salsas, thick and delicious frozen drinks, baby foods, etc. The blending capabilities are endless!

Attach the work bowl and cover and the The Cuisinart® SmartPower Duet® Blender/Food Processor becomes a fully functioning Cuisinart® classic food processor. Chop raw and cooked foods, including meats, to any consistency. The reversible slicing/shredding disc and feed tube let you make mountains of vegetables, fruits and most cheeses in minutes. This combination of Cuisinart's two most versatile appliances into one promises years of happy and healthy food preparation.

BLENDER FEATURES AND BENEFITS

1. Cover

Just press on; no turning or twisting required. Tightfitting seal resists leakage.

2. 2-oz. Measured Pour Lid

Allows you to measure and add ingredients neatly without removing the cover.

3. 40-oz. Glass Jar with Dripless Pour Spout

Has a unique, sturdy, widemouth design and a dripless pour spout for no-mess pouring.

4. Leakproof Rubber Gasket (not shown)

Holds the glass jar snugly in position for safe operation.

5. High-Quality Cutting Assembly with Patented Stainless Steel Blades

Is strong enough for all blender tasks, including tough jobs, from ice crushing to chopping delicate herbs. **Note: Blades are very sharp...handle carefully.**

6. Collar (Locking Ring)

Collar is self-aligning so that the glass blender jar slides easily into position, eliminating the frustration of twisting and turning the blender jar to lock it into place.

7. Heavy-Duty Motor Base

Motor base is so sturdy and stable, it will not “walk” on your counter – even during ice crushing! The motor is strong enough to handle all blending tasks, including crushing ice without liquid, and is backed by a three-year limited warranty.

8. 7-Speed Touchpad Control with Indicator Lights

Easy to use, read and clean. Seven speeds give you great versatility – use low speeds for delicate blending all the way up to high speeds for cheese, garlic, or lemon zest. The red LED lights clearly indicate what blender speed you are using.

8a. Pulse Button

Allows you to pulse at any speed from high to low, so you can blend ingredients only as much as needed.

8b. Ice Crush Button (Blender Only)

Activates the ice crushing speed. This button is preset to the best speed for crushed ice. However, you can crush ice at any speed. The food processor attachment is not intended to crush ice. Use the blender jar for this.

8c. Food Processor Button

Is preset to the best speed for all food processing tasks. Always use this button when food processing. This speed may also be used with blender jar.

9. Slip-Proof Feet

Prevent movement during use and prevent damaging marks on countertops or tables.

10. Hidden Cord Storage Compartment (not shown)

Keeps countertop safe and neat by conveniently storing excess cord.

11. Impact-Resistant Plastic Housing

Is crafted of the finest quality materials to resist staining, cracking, and odors.

12. Innovative Cuisinart® Design

The combination of power, performance, sturdiness, and easy cleanup makes this blender a winner.

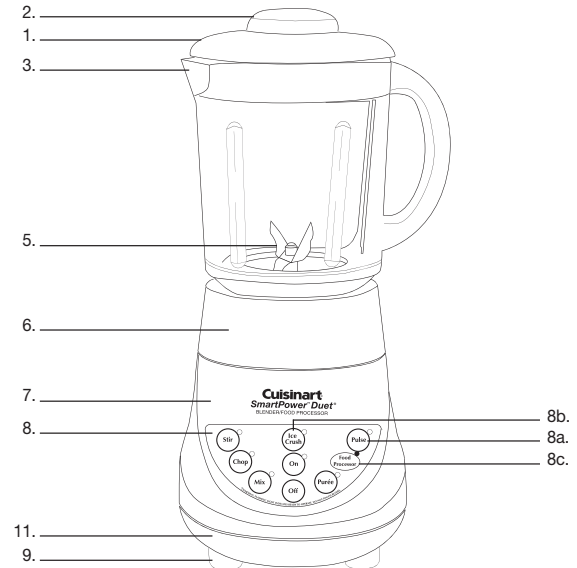

BLENDER ASSEMBLY, USE AND CARE

To use your Cuisinart® SmartPower Duet® Blender/Food Processor, begin by assembling the blender jar.

1. Turn the blender jar (a) upside down, and place it flat on a sturdy surface.
2. Position the rubber gasket (b) on the round opening on the bottom of the blender jar.
3. Turn the cutting assembly (c) upside down, and place the blade end in the blender jar opening. **Note: Blades are very sharp, handle carefully.**
4. Secure the rubber gasket and cutting assembly in position by placing the smaller opening of the locking ring (d) on top of the cutting assembly. Engage threads by twisting the locking ring clockwise until tightened. Make sure locking ring is tightly fastened to blender jar. Once assembled, turn the blender jar right side up.
5. Push the cover onto the top of the blender jar. Insert the measured pour lid into the cover, aligning the tabs in the pour lid with the slots in the cover. Twist clockwise to lock pour lid into the cover.
6. Place the blender jar on the motor base so that the jar markings are facing you and the handle is positioned to one side.
7. Plug in power cord. Your blender is now ready to be used.

Helpful Reminders

- Once the cover is in position, additional ingredients can be added during blending by simply twisting the measured pour lid counterclockwise until the tabs in the pour lid align with the slots in the cover. Pull up the pour lid, add ingredients, and replace the pour lid.
- Cover should always be in place while the unit is ON.
- Warning: Do not place blender jar on base while motor is running.
- Do not twist locking ring from blender jar when removing blender jar from base. Simply lift blender jar from motor base.
- Boiling liquid or solid frozen foods (with the exception of ice cubes or ½" pieces of frozen fruit) should never be placed in the blender jar.

- Do not place ice, frozen foods or very cold liquids in a blender jar that has come directly from a hot dishwasher.
- Do not place very hot liquids or foods in a blender jar that has come directly from the freezer. Boiling liquids should cool for 5 minutes before being placed in blender jar.
- Follow Cleaning and Maintenance instructions on page 7 prior to your first use.

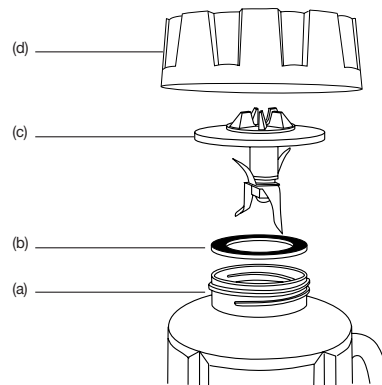

BLENDER OPERATION

1. Place the motor base of your Cuisinart® SmartPower Duet® Blender/Food Processor on a flat, sturdy surface. It is important that the surface be clean and dry. Assemble the blender by following the Assembly instructions. Once the jar is assembled and is in position on the motor base, plug the Cuisinart® SmartPower Duet® Blender/Food Processor into an electrical outlet.
2. Add all necessary ingredients to the blender jar and replace the cover. You may add additional ingredients by lifting the measured pour lid and dropping ingredients through the fill area. Replace the measured pour lid after adding ingredients. Do not place hands into blender jar with blender plugged in.

Note: Add liquid ingredients first, then follow with solid ingredients. This will provide more consistent blending and prevent unnecessary stress on the motor.

Tip: Liquid ingredients can be measured in the measured pour lid, using the measurement marking. Solid ingredients can be added by simply dropping them through the fill area into the blender jar. Replace the measured pour lid after adding ingredients.

Note: To remove blender jar cover, lift edge of cover upward. Lifting measured pour lid will not remove cover.

3. **To start blending:** press the On button. The red On LED light will flash, indicating that the blender is turned on but no speed has been selected.
4. Press the desired blending speed: both the On indicator light and the activated

speed indicator light will glow. The blender will now be functioning at the desired speed. It is possible to switch speeds without pressing the Off button, by simply pushing the next desired speed button.

- To reset the blender:** The unit has an advanced thermal resettable fuse feature. In the event of an overload condition the unit will shut down to protect the motor from overheating. When this happens, to reset the unit, unplug the blender and let it cool down for a minimum of 15 minutes. Then look to reduce the contents and/or clear any jams, then restart as noted in the operating directions.
- To stop the blending process:** re-press the activated speed button. The blending process will stop. The red On indicator light will continue to flash to let you know that the blender is still on and can be reactivated by pushing the desired speed button. The blender can be completely deactivated and stopped from any speed by pushing the Off button. You will need to press the On button again to continue blending.

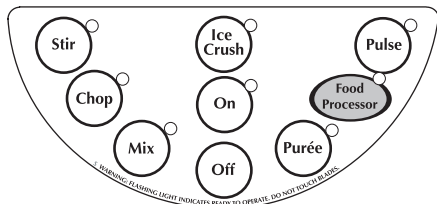

- Pulse Mode:** while the blender is turned on, you can create a burst of power for quick, efficient blending by activating this function. To do so, first push the Pulse button, which will cause the Pulse indicator light to flash. Next, push and release the desired speed button. Repeat as desired. You determine the duration of each pulse. While pulsing, all indicator lights (the On, the Pulse, and the desired speed) will glow.

The Pulse function can be used to break apart larger pieces of food or to control the texture of food when chopping. The Pulse function is also effective in starting the blending process when you do not want continuous power, or when processing items that do not require an extended amount of blending.

- To crush ice:** Use blender jar only. The Cuisinart® SmartPower Duet® Blender/Food Processor motor is strong enough to crush ice without liquid at any speed; however, for your convenience we have preset the best speed for ice crushing. To give you greater control, the Ice Crush function automatically operates as a Pulse function. To crush ice, place ice cubes in the blender jar, and place the cover and the measured pour lid on the blender jar. Press the On button. Press the Ice Crush

button in short pulses until ice is crushed to desired consistency. See the Recipe Tips section on page 12 for more details.

- To dislodge food:** use a rubber or plastic spatula to help remove food lodged around the cutting assembly.

DO NOT USE SPATULA UNTIL YOU HAVE TURNED OFF AND UNPLUGGED THE BLENDER. Replace the cover and measured pour lid and continue blending if necessary. Make sure spatula is not inside the blender jar before blending.

- When finished blending:** press the Off button, and unplug the blender from the electrical outlet. Never remove the blender jar from the motor base until pressing the Off button. Do not twist locking ring from blender jar when removing jar from motor base. Simply lift blender jar from motor base. Do not place hands into blender jar with blender plugged in.

QUICK REFERENCE GUIDE

FOR BLENDER FUNCTION

To activate blender	Press On- The blender is in On mode.
To begin blending	Press desired speed button
To change speeds	Press desired speed button.
To pulse	In On mode press Pulse, then press and release desired speed button as needed.
To crush ice	In On mode, press and release Ice Crush button as needed.
To stop blending and deactivate blender	Press Off button.
To stop blending in Pulse or Ice Crush mode	Release button.
To stop blending in Stir, Chop, Mix, Purée, or Food Processor mode	Press speed button again. This will return the blender to On mode. Press Off button to turn blender off.

SPEED SELECTION GUIDE

FOR BLENDER FUNCTION

Refer to this guide to choose the best speed for your desired result.

Ingredient/Recipe	Speed	Result
Reconstituting frozen orange juice concentrate	Stir	Smooth and full-bodied
Mayonnaise	Stir	Thick and creamy
Salad dressings	Stir	Desired consistency
Nuts	Chop	Coarse to fine
Whipping cream	Mix	Thick topping
Bread crumbs	Mix	Uniformly fine
Grating citrus zest	Purée	Uniformly fine
Milk shakes	Purée	Smooth and creamy
Baby food	Purée	Smooth and creamy
Health drinks	Food Processor	Smooth and creamy
Frozen cocktails	Food Processor	Thick and slushy
Grinding hard cheese	Food Processor	Coarse to fine
Spices	Food Processor	Coarse to fine
Ice	Ice Crush	Snowy

CLEANING AND MAINTENANCE

Always unplug your Cuisinart® SmartPower Duet® Blender/Food Processor from the electrical outlet before cleaning. The blender is made of corrosion-resistant parts that are easy to clean. Before first use and after every use, clean each part thoroughly. Periodically check all parts before reassembly. If any part is damaged or blender jar is chipped or cracked, DO NOT USE BLENDER.

Remove the blender jar from the motor base by lifting straight up and away. Twist off the locking ring by turning counterclockwise. Remove the cutting assembly and rubber gasket. Wash in warm soapy water; rinse and dry thoroughly. Place the locking ring in the upper rack of the dishwasher or wash in warm water.

CAUTION: Handle the cutting assembly carefully. It is **SHARP** and may cause injury. Do not attempt to remove blades from cutting assembly.

Remove the blender jar cover and the measured pour lid. Wash in warm, soapy water; rinse and dry thoroughly, or place in the upper rack of the dishwasher. The blender jar should be washed in warm soapy water and rinsed and dried thoroughly. The blender jar can also be placed upside down in the dishwasher.

Finally, wipe the motor base clean with a damp cloth to remove any residue, and dry thoroughly. Never submerge the motor base in water or other liquid, or place in the dishwasher.

Any other servicing should be performed by an authorized service representative.

Tip: You may wish to clean your blender cutting assembly as follows: Squirt a small amount of dishwashing liquid into assembled blender jar and fill halfway with warm water. Run on Stir for 15 seconds. Repeat using clean tap water. Empty blender jar and carefully disassemble parts. Wash cutting assembly, gasket and locking ring in warm, soapy water. Rinse and dry all parts thoroughly.

DO'S AND DON'TS WHEN USING YOUR BLENDER/FOOD PROCESSOR

Do:

- Make sure the electrical outlet is rated at the same voltage as that stated on the bottom of the blender motor base.
- Always use the motor base on a clean, sturdy and dry surface.
- Always add liquid ingredients to the blender jar first, then add remaining ingredients. This will ensure that ingredients are uniformly mixed.
- When using either appliance, cut most foods into cubes approximately ½" to 1" to achieve a more uniform result. Cut all cheeses into pieces no larger than ½".
- When using blender, use the measured pour lid to measure liquid ingredients such as alcohol. Replace measured pour lid after ingredients have been added.
- When using either appliance, use a rubber or plastic spatula as needed, only when the blender is turned OFF. Never use metal utensils, as damage may occur to the blender jar/work bowl or cutting assembly.
- Place blender cover on firmly. Always operate the blender with the cover on.
- Make sure locking ring is tightly attached to blender jar.
- After using blender, always remove locking ring, cutting assembly, and rubber gasket before cleaning.
- When scraping the blender jar with a spatula, remove the food from the sides of the blender jar and place it in the center of the blender jar, over the cutting assembly.
- When chopping fresh herbs, garlic, onion, zest, bread crumbs, nuts, spices, etc., make sure the blender jar and cutting assembly are completely dry.
- If food tends to stick to the sides of the blender jar or food processor work bowl during use, pulse in short bursts.
- When using food processor, pulses should be short bursts. Space the pulses so the blades stop rotating between pulses.

Don't:

- Don't store food or liquids in your blender jar or food processor work bowl.
- When using blender, don't place cutting assembly and locking ring onto motor base without the blender jar attached.
- Blender or food processor will not mash potatoes, knead dough, or beat egg whites.
- Don't remove blender jar or food processor bowl while unit is on. Keep the blender jar or food processor cover on while blending.
- Don't twist locking ring from blender jar when removing blender jar from motor base. Simply lift blender jar from motor base.
- Don't overprocess foods. Blender or food processor will achieve most desired results in seconds, not minutes.
- Don't overload blender or food processor. If the motor stalls, turn off immediately, unplug the unit, and remove a portion of the food; then continue.
- Don't use any utensil inside the blender jar or food processor bowl while the motor is on.
- Don't use any container or accessories not recommended by Cuisinart. Doing so may result in injury.
- Don't place hands inside the blender jar or food processor bowl when blender is plugged in.
- Don't add boiling liquids or frozen foods (except ice cubes or ½" pieces of frozen fruit) to glass blender jar. Boiling liquids should cool for 5 minutes before being placed in blender jar.
- The food processor accessory is not intended to crush ice. This could damage the chopping blade and will damage work bowl.

FOOD PROCESSOR FEATURES

1. Food pusher with oil dispenser
2. Work bowl cover with feed tube
3. Stainless steel chopping blade
4. Stainless steel reversible slicing/shredding disc
5. Adapter stem
6. Clear work bowl
7. Gearbox collar
8. **Motor base**
Used for both the blender jar and the food processor bowl

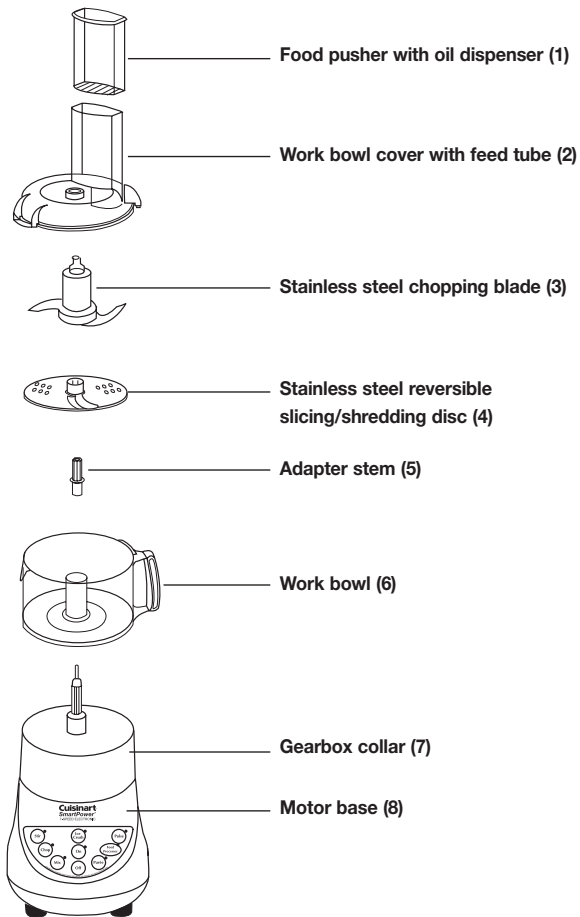

FOOD PROCESSOR ASSEMBLY, USE AND CARE

Please note that the bowl with collar will fit on the base in eight different positions. The handle can be in front or on either side and the feed tube in front, back, or on either side. **Directions for use reference a certain position for instructional purposes only.**

FOOD PROCESSOR ASSEMBLY FOR CHOPPING, PURÉEING AND MIXING

1. Hold gearbox collar in one hand and work bowl handle in the other. Twist bowl clockwise onto collar.
2. Place collar with bowl onto motor base with handle facing front.
3. Place chopping blade over shaft in work bowl. Chopping blade should slide easily to the bottom of the bowl. Lower blade will almost touch bottom of bowl.

BE SURE TO HANDLE THE METAL BLADE WITH CARE AS IT IS RAZOR SHARP!

4. Place food to be processed in work bowl. Put cover on work bowl, with feed tube at about 11 o'clock.

Turn the cover clockwise until it fits into position. Cover lock must click into locked position prior to use. If you have trouble fitting the cover on the work bowl, turn chopping blade hub slightly and replace cover.

5. The food pusher fits in feed tube with the more rounded side toward the outside of the bowl. **ALWAYS USE PUSHER TO GUIDE FOOD THROUGH FEED TUBE. NEVER USE YOUR FINGERS OR SPATULA.**
6. Plug your Cuisinart® SmartPower Duet® Blender/Food Processor into a wall outlet. Push the On button and then the Food Processor button to start chopping or puréeing. It is recommended that one hand be placed on the food processor lid while in use, to provide unit stability. If the machine doesn't start, make sure it is plugged in and the work bowl and cover are locked into place. The food processor will not start until the collar, work bowl and work bowl lid are locked into place. Nevertheless, always unplug the unit before placing hands into the food processor bowl. **NOTE:** The motor base will start, but the food processor blade will not turn until assembled properly.

FOOD PROCESSOR ASSEMBLY FOR SLICING AND SHREDDING

1. Hold collar in one hand and bowl handle in the other. Twist bowl clockwise onto collar.
2. Place collar with bowl onto motor base with handle facing front.
3. Place adapter stem onto the center shaft. **To slice:** Attach disc to stem with the raised edge of slicer on top. **To shred:** Attach disc to stem with the raised shredding slots on top. Place the slicing/shredding disc onto shaft with the desired cutting blade facing up. Be sure to handle the metal blade with care, as it is razor sharp.
4. Place cover on work bowl, with feed tube at about 11 o'clock. Turn cover clockwise until it fits into position. Insert food in feed tube.
5. Hold pusher with the more rounded side toward the outside of the bowl and insert it in feed tube over food. Always use pusher to guide food through feed tube. Never use your fingers or spatula.
6. Plug your Cuisinart® SmartPower Duet® Blender/Food Processor into a household electrical outlet.
7. To remove cover, unlock it by turning it counterclockwise, then lift it straight up.

FOOD PROCESSOR OPERATION

Your Cuisinart® SmartPower Duet® Blender/Food Processor appliance comes with a Food Processor button. This button is the perfect speed for all your food processing tasks. Always use this speed when using the food processor. You may also use the Pulse button with this function for pulse-chopping.

To use your food processor, make sure that the bowl is assembled properly and the blade or slicing/shredding disc and the cover are locked into place.

When you use the control panel, the LED will light next to each button you press.

Press the On button. For continuous operation, press the Food Processor button. Motor will start if you have followed assembly instructions.

To turn motor off, press the Food Processor button again or the Off button.

For On/Off operation, called pulse-chopping or pulsing, press the On button, press the Pulse button, and then press and release the Food Processor button the desired number of times. Motor runs as long as you hold the Food Processor button down. The motor stops when you release control switch. Try it a few times.

You control the duration and frequency of pulses by the length of time you hold the Food Processor button down and the rate at which you press it. Allow enough time between pulses to let food in work bowl fall to bottom.

Always use the Food Processor button for pulse-chopping. Never turn cover back

and forth to start and stop processor.

USING THE FOOD PROCESSOR TO CHOP, PURÉE, AND MIX

Refer to Food Processor Assembly instructions on page 10.

1. Remove cover and put food into work bowl. First, cut food into $\frac{3}{4}$ " pieces. You will get a more even chop if you start with pieces that are all the same size.
Put pieces into work bowl with metal blade in place. You can put in up to 1 cup of food at a time. If you want to process more, do it in batches.
2. Put on cover and lock it. Insert pusher. It is recommended that one hand be placed on the food processor lid while in use, to provide unit stability. Press the On button, press the Pulse button, and the Food Processor button (to pulse), then release. Repeat two to three times. Each time blade stops, let food pieces drop to the bottom of bowl before pulsing again. This ensures that the blade will chop them at every pulse.

NOTE: The unit has an advanced thermal resettable fuse feature. In the event of an overload condition the unit will shut down to protect the motor from overheating. When this happens, to reset the unit, unplug the blender and let it cool down for a minimum of 15 minutes.

Watch

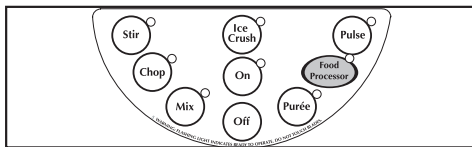

what

happens to the food. With pulse-chopping technique, you can get an even chop without danger of overprocessing. Check texture by looking through work bowl. Be careful not to overprocess.

For a coarse chop, pulse only a few times.

3. If you want a finer chop or purée, press the On button and then the Food Processor button and let machine run continuously until the food is chopped as fine as you want it. Check frequently through clear cover or bowl to avoid chopping too fine. Use a plastic spatula to scrape down any pieces that stick to inside of bowl.

Onions and other food with a high water content turn into a smooth purée very quickly. Do not over-chop – look at food frequently through work bowl.

To purée, follow same procedure as for chopping, but let machine run until food is a smooth purée.

New users are often surprised at how fast the processor works. You will quickly get

used to its great speed.

These are some conditions that affect your results:

- Size of pieces you put in bowl – all should be about the same size.
- Amount of food you process – don't add too much.
- Type of processing you choose – continuous or pulse-chopping.

ADDING FOOD WHILE PROCESSING

To add liquid while the machine is running, pour it through open feed tube. This is especially useful when making mayonnaise or dressings.

A small hole in the pusher allows you to add liquids in a very slow, steady stream – useful when making sauces.

When you want to add small pieces of food like cheese, meat or garlic cloves while machine is running, drop them through open feed tube.

To prevent spills when adding sugar and other dry ingredients, use a funnel.

REMOVING

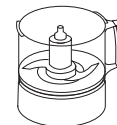

PROCESSED FOOD

Before removing processed food, press Off button and wait for blade to stop spinning. Then remove cover by turning it counterclockwise. Never try to remove cover and work bowl together; this can damage work bowl.

It is important not to let metal blade fall out of work bowl as you empty it.

Here are two ways to prevent it from falling out:

1. Before tilting bowl, use spatula to remove food from around blade. Carefully remove blade by the plastic hub.
2. Hold top of blade in place with finger or spatula while pouring out processed food.

At this point, you may either lift the work bowl off motor base or hold the collar at the base and turn the handle of the bowl counterclockwise and lift blade straight up.

Your Cuisinart® SmartPower Duet® Blender/Food Processor makes many everyday food preparation tasks much easier and faster. Follow these guidelines to get best results when using metal blade with food you prepare most often.

NOTE: Occasionally, a piece of food may become wedged between the blade and

the work bowl. If this happens, remove the cover, lift the blade out carefully and remove the wedged piece. Empty the bowl, reinsert the blade and lock the cover into place. Process smaller amounts of the food at one time.

USING THE FOOD PROCESSOR TO SLICE AND SHRED

1. Assemble clear work bowl on collar and base in the usual way.
(See page 10.)
2. Pick up adapter stem. Hold stem by side that has the octagon shape (eight sided) and push rounded side down as far as it will go on motor shaft.
3. Place the reversible slicing/shredding disc with the desired cutting edge facing up onto the adapter stem. Always handle slicing/shredding disc by the rim. Never touch sharp cutting blades.
4. Put cover on work bowl, lock it into place by twisting it clockwise and insert food in feed tube.
5. Inset pusher. Use moderate pressure to push down on pusher with one hand while using your other hand to push the On button, Pulse button, and hold down the Food Processor button. Slicing and shredding only take a few seconds.

Wait until disc stops spinning before removing cover. When it stops, remove cover before removing work bowl. Never try to remove cover and work bowl together; this could damage work bowl.

6. Remove slicing/shredding disc before removing work bowl. To remove it, grasp flat top section of adapter stem and lift it straight up.

Holding work bowl collar, turn work bowl counterclockwise and lift it straight up to remove it from base.

RECIPE TIPS

You'll find many easy ways to prepare savory, healthful meals with your Cuisinart® SmartPower Duet® Blender/Food Processor. The simple recipes that follow include some old Cuisinart favorites as well as some creative combinations that are sure to please your friends and family. Thanks to the superior ice crushing power of the SmartPower Duet® Blender/Food Processor, you'll also be able to make delicious frozen drinks.

Chopping Nuts

Pulse ½ cup of nuts (shells removed) on Chop 4 to 5 times. Turn blender off; scrape blender jar with spatula. Turn blender on and pulse on Chop 2 to 3 times. Turn blender off. Pulse fewer times for more coarsely chopped results. For best results, process no more than 1 cup at a time.

Bread, Cookie or Cracker Crumbs

For best results, use day-old bread (drier bread works best). Break bread slices into ½" pieces, and process no more than 1 cup of pieces at a time on Mix for 5 to 10 seconds. Crackers and cookies should also be broken into ½" pieces; process 1 cup at a time on Mix for 10 to 15 seconds. Turn blender off.

Crushing Ice

(Blender jar only)

Add up to 10 large ice cubes to blender jar. Press the Ice Crush button, using short bursts, 10 times or until cubes are the consistency of snow. Turn blender off. Pulse fewer times if coarsely chopped ice is desired.

Grating Citrus Zest

For best results, blender jar and cutting assembly must be clean and dry. Remove zest from fruit in strips (using vegetable peeler). Use no more than 8 strips at a time (zest of one medium lemon). Cut strips in half. Add strips and 1 teaspoon sugar (from recipe) to the blender jar. Blend on Food Processor speed for 15 to 20 seconds. Turn blender off.

Grinding Hard Cheese

Cut cheese into ½" pieces. Blend on Food Processor speed for 30 seconds. Turn blender off. For best results, grind no more than 3 ounces of cheese at a time.

Grinding Spices

For best results, blender jar and cutting assembly must be clean and dry. Add ¼ to ½ cup of spices, seeds or peppercorns to blender jar. Blend on Food Processor speed for 30 to 35 seconds. Turn blender off.

Whipping Cream

Whip 1 cup of cream (whipping or heavy cream) at a time. Blend on mix, and process for 45 to 60 seconds or until creamy and smooth. If making sweetened cream, add sugar after 10 seconds. Turn blender off. Makes about 1 cup.

Puréeing Sun-Dried Tomatoes

Rehydrate 1 ounce of sun-dried tomatoes in 1 cup boiling water. Allow to sit for 10 minutes or until softened. Add tomatoes and water to blender jar. Cover and pulse on Food Processor speed 5 times; then run continuously on Food Processor speed for 15 to 20 seconds. Turn blender off. Drain in fine strainer if desired. Makes about ½ cup of puréed tomatoes.

CLEANING AND STORING YOUR CUISINART® SMARTPOWER DUET® FOOD PROCESSOR ATTACHMENT

Store the chopping blade and slicing/ shredding disc as you would sharp knives – out of the reach of children.

The work bowl, cover, pusher, chopping blade, and slicing/shredding disc are top-shelf dishwasher safe. When placing parts in your dishwasher, insert the work bowl upside down. Remember where you place the sharp blade and disc, and be certain to unload the dishwasher carefully.

The gearbox collar is not immersible. To clean, just wipe with a damp cloth. If you wash the blades and discs by hand, do it carefully. Avoid leaving them in soapy water where they may disappear from sight. To clean the metal blade, fill the work bowl with soapy water, hold the blade by its plastic center and move rapidly up and down on the center shaft of the bowl. Use of a spray hose is also effective. If necessary, use a brush.

The work bowl should not be placed in a microwave oven.

RECIPES

For use with the Cuisinart® SmartPower Duet® Blender only.

Before following any of these Cuisinart® recipes, make sure the Cuisinart® SmartPower Duet® Blender/Food Processor is properly assembled. Follow the Assembly directions on page 5 of this instruction booklet for correct blender assembly procedure. **Note:** Always turn power base off prior to removing bowl cover.

FROZEN BEVERAGES

Frozen Cranberry Orange Mimosa

Makes ten servings

- 1 cup cranberry juice cocktail, chilled**
- 1 cup orange juice, chilled**
- 1½ cups ice cubes**
- 1 bottle (750 ml) brut champagne, chilled**

Place cranberry juice, orange juice, and ice cubes in the Cuisinart® SmartPower Duet® blender jar in order listed. Place cover on blender jar.

Turn blender on and process on Food Processor speed until thick and frothy, about 30 to 40 seconds. Turn blender off.

Pour $\frac{1}{3}$ cup juice mixture into each champagne glass. Top with chilled champagne. Serve immediately.

*Nutritional information per serving:
Calories 32 (0% from fat) • carb. 8g • pro. 0g • fat 0g • sat. fat 0g
• chol. 0mg • sod. 14mg*

Frozen Fruit Daiquiri

Makes five 4-ounce servings

- 4 ounces frozen limeade concentrate, thawed**
- 3 ounces light rum**
- 2 cups ice cubes**
- 1 cup ripe fruit, cut into 1-inch pieces
(strawberries, bananas, peaches)**

General Guidelines for Preparing Foods for Slicing and Shredding

Food	To Prepare for Slicing	To Prepare for Shredding
Long narrow foods like carrots, celery, cucumbers, and zucchini	Cut into even lengths about 1 inch shorter than height of feed tube. Stand pieces upright in feed tube, flat side down, adding enough pieces so they cannot tilt.	For long shreds, cut into largest size that will fit sideways in feed tube. Stack in feed tube to about 1 inch from top. For shorter shreds, stand pieces upright in feed tube, flat side down (as described in slicing column).
Apples, onions, potatoes, peppers, tomatoes and other large round fruits and vegetables	Cut one end flat, then cut lengthwise in halves or quarters. Pack solidly in feed tube to prevent tilting.	Same as slicing. Place in feed tube sideways for longer shreds, or upright for shorter shreds.
Strawberries, mushrooms, radishes and other small, round fruits and vegetables	Slice off top and bottom, leaving center section. Place in feed tube, flat side down. Fill feed tube to about 1 inch from top. Use light to moderate pressure.	Radishes shred well.
Cabbage, iceberg lettuce	Cut off top and bottom, leaving center section. Cut into wedges to fit feed tube upright. Remove core. Cut top and bottom pieces in similar wedges.	Same as slicing.
Uncooked meat and poultry (8 oz. maximum at one time)	Use boneless cuts. Cut into feed-tube lengths. Remove skin if desired. Wrap in plastic wrap and put in freezer until it feels hard when you try to squeeze it but is still easily pierced through with tip of sharp knife. Remove plastic wrap and stand upright in feed tube. Note: Chicken and beef for stir-fries should be sliced with the grain. Boned, skinned chicken breast will usually fit when frozen as described above and cut in half crosswise.	Do not shred.
Soft cheeses like mozzarella	Do not slice	Chill in freezer for 5 minutes before processing. Cut into pieces to fit feed tube. Stand pieces in feed tube and use light pressure on pusher. Use 4 oz. maximum.
Medium-hard cheeses like Cheddar and Swiss	Cut into pieces to fit feed tube. Stand pieces in feed tube and use light pressure on pusher.	Same as slicing. Chill 5 minutes in freezer before processing. Use 4 oz. maximum.
Hard cheeses like Parmesan	Do not slice.	Do not shred.

Place ingredients in the Cuisinart® SmartPower Duet® blender jar in order listed. Place cover on blender jar. Turn blender on and process on food processor speed until slushy, about 45 to 50 seconds. Turn blender off.

Serve immediately.

Nutritional information per serving:

*Calories 90 (0% from fat) • carb. 13g • pro. 0g • fat 0g • sat. fat 0g
• chol. 0mg • sod. 3mg*

Frozen Daiquiri

Makes four 4-ounce servings

- 4 ounces frozen limeade concentrate, thawed**
- 3 ounces light rum**
- 2 cups ice cubes**

Place ingredients in the Cuisinart® SmartPower Duet® blender jar in order listed. Place cover on blender jar. Turn blender on and process on Food Processor speed until slushy, about 45 to 50 seconds. Turn blender off. Serve immediately.

Nutritional information per serving:

*Calories 105 (0% from fat) • carb. 14g • pro. 0g • fat 0g • sat. fat 0g
• chol. 0mg • sod. 4mg*

Rum and Orange Freeze

Makes four 4-ounce servings

- 1 cup orange juice**
- 1½ ounces dark rum**
- 1 cup ice cubes**

Place ingredients in the Cuisinart® SmartPower Duet® blender jar in order listed. Place cover on blender jar. Turn blender on and process on food processor speed until slushy, about 30 seconds. Turn blender off. Serve immediately.

Nutritional information per serving:

*Calories 45 (0% from fat) • carb. 6g • pro. 0g • fat 0g • sat. fat 0g
• chol. 0mg • sod. 2mg*

Margarita

Makes four 4-ounce servings

- ½ cup lime juice**
- 4 ounces tequila**
- 1 tablespoon sugar**
- 2 cups ice cubes**

Place ingredients in the Cuisinart® SmartPower Duet® blender jar in order listed. Place cover on blender jar. Turn blender on and process on food processor speed until slushy, about 45 to 60 seconds. Turn blender off. Serve immediately.

Nutritional information per serving:

*Calories 94 (0% from fat) • carb. 6g • pro. 0g • fat 0g • sat. fat 0g
• chol. 0mg • sod. 4mg*

Piña Colada

Makes two 6-ounce servings

- ½ cup unsweetened pineapple juice**
- 2 ounces sweetened cream of coconut**
- 2 ounces dark rum**
- 1 cup ice cubes**

Place ingredients in the Cuisinart® SmartPower Duet® blender jar in order listed. Place cover on blender jar. Turn blender on and process on Food Processor speed until slushy, about 45 to 50 seconds. Turn blender off. Serve immediately.

Nutritional information per serving:

*Calories 143 (25% from fat) • carb. 10g • pro. 1g • fat 4g • sat. fat 2g
• chol 11mg • sod. 17mg*

MILK SHAKES & FRAPPES

Orange Creamsicle

Makes one 12-ounce serving

- ¾ cup fat-free milk**
- 2 scoops (8 ounces) orange sherbet**
- 2 tablespoons instant nonfat dry milk**
- ½ teaspoon pure vanilla extract**

Place ingredients in the Cuisinart® SmartPower Duet® blender jar in order listed. Place cover on blender jar. Turn blender on and process on Food Processor speed until smooth, about 30 seconds. Turn blender off. Serve immediately.

Nutritional information per serving:

*Calories 396 (9% from fat) • carb. 76g • pro. 14g • fat 4g • sat. fat 3g
• chol. 20mg • sod. 265mg*

Chocolate Milk Shake

Makes two 8-ounce servings

- 1 cup reduced fat milk**
- 1 scoop (4 ounces) vanilla ice cream**
- 2 tablespoons chocolate syrup**

Place ingredients in the Cuisinart® SmartPower Duet® blender jar in order listed. Place cover on blender jar. Turn blender on and process on Purée until smooth and creamy, about 25 to 30 seconds. Turn blender off. Serve immediately.

Nutritional information per serving:

*Calories 243 (41% from fat) • carb. 29g • pro. 7g • fat 11g • sat. fat 7g
• chol. 34mg • sod. 127mg*

Variation: For a strawberry milk shake, substitute strawberry syrup an strawberry ice cream.

Cappuccino Shake

Makes four 8-ounce servings

- 1 cup espresso or strong coffee**
- ½ cup half-and-half**
- ¼ cup sugar***
- 1 cup ice cubes**
- ground cinnamon**

Place all ingredients except cinnamon in the Cuisinart® SmartPower Duet® blender jar in order listed. Place cover on blender jar. Turn blender on and process on food processor speed until smooth, about 25 to 30 seconds. Turn blender off. Pour into glasses, and sprinkle with cinnamon. Serve immediately.

* Use less sugar (about 3 tablespoons) if less sweetness is desired.

Nutritional information per serving:

*Calories 87 (31% from fat) • carb. 14g • pro. 1g • fat 3g • sat. fat 2g
• chol. 11mg • sod. 14mg*

Variation: Pour mixture into ice cube trays, and freeze until solid. Place in blender jar and crush, using Ice Crush to make a refreshing frozen dessert.

Ice Cream Soda

Makes two 12-ounce servings

- 1 cup reduced fat milk**
- 1 scoop (4 ounces) vanilla ice cream**
- 2 tablespoons chocolate syrup**
- 1 cup ginger ale**

Place milk, ice cream, and chocolate syrup in the Cuisinart® SmartPower Duet® blender jar in order listed. Place cover on blender jar. Turn blender on and process on Purée until smooth and creamy, about 40 to 45 seconds. Turn blender off. Divide ginger ale into two tall glasses (about 14 to 16 ounces each). Add ice cream mixture and stir gently. Serve immediately.

Nutritional information per serving:

*Calories 287 (34% from fat) • carb. 40g • pro. 7g • fat 11g • sat. fat 7g
• chol. 34mg • sod. 136mg*

Mocha Shake

Makes one 12-ounce serving

- 1** **teaspoon instant coffee crystals**
- 1** **tablespoon hot water**
- ½** **cup reduced fat milk**
- 2** **scoops (8 ounces) vanilla low-fat frozen yogurt or vanilla ice milk**
- 2** **tablespoons chocolate syrup**

Dissolve coffee crystals in hot water and place in the Cuisinart® SmartPower Duet® blender jar. Add remaining ingredients in order listed. Place cover on blender jar. Turn blender on and process on Purée until smooth, about 25 to 30 seconds. Turn blender off. Serve immediately.

Nutritional information per serving:

*Calories 479 (28% from fat) • carb. 71g • pro. 15g • fat 15g • sat. fat 7g
• chol. 43mg • sod. 255mg*

SMOOTHIES

All-Fruit Smoothie

Makes six 6-ounce servings

- ⅓** **cup orange juice**
- 1** **cup cantaloupe, cut into 1-inch pieces**
- 1** **cup raspberries**
- 1** **cup canned pineapple chunks, drained**
- 1** **cup navel orange segments, cut into 1-inch pieces**
- 1** **cup strawberries, cut into 1-inch pieces**
- 1** **medium banana, cut into 1-inch pieces**
- 1** **cup ice cubes**

Layer the ingredients in the Cuisinart® SmartPower Duet® blender jar in the order listed. Do not pack fruit tightly into blender jar. Place cover on blender jar. Turn blender on and process on Food Processor speed until smooth, about 30 to 40 seconds. Turn blender off.

Note: The riper the fruit, the sweeter the smoothie.

Nutritional information per serving:

*Calories 92 (0% from fat) • carb. 22g • pro. 1g • fat 0g • sat. fat 0g
• chol. 0mg • sod. 5mg*

Banana-Pineapple Freeze

Makes two 8-ounce servings

- 1** **cup unsweetened pineapple juice**
- ½** **medium banana, cut into 1-inch pieces**
- ¼** **cup instant nonfat dry milk**
- 1** **cup ice cubes**

Place ingredients in the Cuisinart® SmartPower Duet® blender jar in order listed. Place cover on blender jar. Turn blender on and process on Food Processor speed until smooth, about 25 to 30 seconds. Turn blender off. Serve immediately.

Nutritional information per serving:

*Calories 152 (0% from fat) • carb. 32g • pro. 6g • fat 0g • sat. fat 0g
• chol. 3mg • sod. 87mg*

SAUCES/DRESSINGS/VINAIGRETTES

Chocolate Sauce

Makes six tablespoons

- 3** **squares (1-ounce) semisweet chocolate, each broken into 8 pieces**
- 1½** **teaspoons sugar**
- ¼** **cup boiling water, cooled for 5 minutes**

Place chocolate and sugar in the Cuisinart® SmartPower Duet® blender jar. Place cover on blender jar. Turn blender on and process on Food Processor speed until coarsely chopped, about 10 to 15 seconds.

Add water, and process on Food Processor speed until smooth, about 10 seconds. Turn blender off. Serve immediately or cool and refrigerate in an airtight container for up to 4 weeks. Reheat before serving.

Nutritional information per tablespoon:

*Calories 85 (53% from fat) • carb. 9g • pro. 1g • fat 5g • sat. fat 3g
• chol. 0mg • sod. 0mg*

Tomato Sauce

Makes four 2-ounce servings

- 1** 28-ounce can Italian plum tomatoes, drained
- 2** medium shallots, peeled, cut into ½-inch pieces
- ½ teaspoon dried oregano
- ½ teaspoon salt
- ½ teaspoon sugar

Place ingredients in blender jar in order listed. Place cover on blender jar. Turn blender on and process on Purée until coarsely chopped, about 10 to 15 seconds. Turn blender off. Transfer to skillet or saucepan; simmer over medium-low heat, stirring occasionally until thick, about 20 to 30 minutes.

Note: Purée 20 to 25 seconds for a smoother sauce.

Nutritional information per serving:
Calories 57 (16% from fat) • carb. 10g • pro. 2g • fat 1g • sat. fat 0g
• chol. 0mg • sod. 312mg

Classic Vinaigrette

Makes ¾ cups

- 1** small garlic clove, peeled and quartered
- ¾ cup vegetable oil
- ¼ cup red wine vinegar
- 1** tablespoon Dijon mustard
- ⅛ teaspoon ground white pepper
- ⅛ teaspoon salt

Place garlic in the Cuisinart® SmartPower Duet® blender jar. Place cover on blender jar. Turn blender on and process on Food Processor speed until finely chopped, about 10 seconds. Add remaining ingredients in order listed, and blend on Stir until combined, about 15 to 20 seconds. Turn blender off. Store in refrigerator in an airtight container for up to 3 weeks.

Nutritional analysis per tablespoon:
Calories 126 (100% from fat) • carb. 0g • pro. 0g • fat 14g • sat. fat 2g
• chol. 0mg • sod. 56mg

BABY FOOD

Puréed Squash

Makes four 2-ounce servings

- 1** medium acorn squash (about 1¼ pounds)
- ¼ cup water

Cut squash in half and remove seeds. Place in a microwave-safe dish with 2 tablespoons of water, cover with plastic wrap, and cook until soft, about 12 to 14 minutes. Allow to cool, and scrape out pulp with a spoon. (There will be about 1½ cups pulp.) Place water, then pulp in the Cuisinart® SmartPower Duet® blender jar. Place cover on blender jar. Turn blender on and blend on Purée until smooth, about 15 to 20 seconds. Turn blender off. Scrape blender jar with a spatula. Turn blender on and blend on Purée for 10 to 15 seconds longer. Turn blender off. Store in an airtight container in the refrigerator for up to 1 week, or freeze in individual portions for up to 2 months.

Nutritional information per serving:
Calories 38 (0% from fat) • carb. 9g • pro. 1g • fat 0g • sat. fat 0g
• chol. 0mg • sod. 2mg

Oatmeal with Bananas

Makes eight 2-ounce servings

- 1½** cups milk
- ½ cup plus **2** tablespoons quick cooking oats
- ½ cup banana cut into 1-inch pieces
(about ½ of a small banana)

Place milk in a small saucepan over medium heat and warm for about 5 minutes (do not boil). Add oats and stir to combine. Reduce heat to low and cook, stirring frequently, until oatmeal thickens, about 1 minute.

Place oatmeal mixture and banana in the Cuisinart® SmartPower Duet® blender jar. Place cover on blender jar. Turn blender on and blend on Purée until smooth, about 20 to 25 seconds. Turn blender off. Store in an airtight container in the refrigerator for 1 to 2 days. Add 1 to 2 tablespoons of milk if the oatmeal thickens too much during storage. Warm before serving.

Nutritional information per serving:
Calories 67 (26% from fat) • carb. 10g • pro. 3g • fat 2g • sat. fat 1g
• chol. 5mg • sod. 23mg

Variation: Substitute other ripe fruits such as peaches, pears or fresh apricots.

Puréeed Peaches

Makes nine 2-ounce servings

- 4 medium peaches (about 6 ounces each), peeled, pits removed, cut into 1-inch pieces**
- ½ cup water**

Place peaches in a steamer basket in a medium saucepan. Add water to a depth of 1 inch in pan. Cover tightly, and bring to a boil over medium-high heat. Steam until peaches are soft but not mushy, about 4 to 5 minutes. Replenish water if necessary during steaming.

Place water and steamed peaches in the Cuisinart® SmartPower Duet® blender jar in that order. Place cover on blender jar. Turn blender on and blend on purée until smooth, about 15 to 20 seconds. Turn blender off. Scrape blender jar with a spatula.

Turn blender on and blend on Purée for an additional 10 to 15 seconds.

Turn blender off. Store in an airtight container in the refrigerator for up to 1 week.

Nutritional information per serving:
Calories 25 (0% from fat) • carb. 6g • pro. 0g • fat 0g • sat. fat 0g
• chol. 0mg • sod. 0mg

Chicken with Noodles

Makes twenty 2-ounce servings

- ½ pound boneless, skinless chicken breast, cut into 1-inch pieces**
- 1½ cups reduced-sodium chicken broth**
- ½ cup egg pastina**
- ½ cup frozen peas**

Place chicken, broth, pastina and peas in a medium saucepan. Cover; bring to a boil over medium-high heat. Reduce heat to low, and simmer, partially covered, until chicken is cooked and pastina is soft but not mushy, about 8 to 9 minutes. Remove from heat and cool for 5 minutes.

Place chicken mixture in the Cuisinart® SmartPower Duet® blender jar. Place cover on blender jar. Turn blender on and blend on Purée until smooth, about 30 seconds. Turn blender off. Scrape blender jar with a spatula. Turn blender on and continue blending on Purée for 30 seconds longer. Turn blender off. Store in an airtight container in the refrigerator for up to 1 week, or freeze in individual portions for up to 2 months.

Note: For a thinner consistency, add 1 to 2 tablespoons of milk.

Nutritional information per serving:
Calories 24 (0% from fat) • carb. 3g • pro. 3g • fat 0g • sat. fat 0g
• chol. 7mg • sod. 17mg

BATTERS

Buttermilk Pancakes

Makes sixteen 4-inch pancakes

- 1½ cups buttermilk**
- 2 large eggs**
- 1¼ cups unbleached, all-purpose flour**
- 3 tablespoons vegetable oil**
- 1 tablespoon sugar**
- 1 teaspoon baking soda**
- ½ teaspoon baking powder**
- ½ teaspoon salt**
- cooking spray**

Place first eight ingredients, in order listed, in the Cuisinart® SmartPower Duet® blender jar (not cooking spray). Place cover on blender jar. Turn blender on and blend on Purée for 10 seconds. Turn blender off. Scrape blender jar with a spatula. Turn blender on and blend on Purée for an additional 15 to 20 seconds. Turn blender off.

Coat a large nonstick skillet or griddle with cooking spray, and heat over medium heat. Pour batter into 4-inch pancakes. When they start to bubble, turn and brown the other side, about 45 seconds. Repeat with remaining batter, coating skillet with cooking spray as necessary.

Nutritional information per pancake:
Calories 75 (36% from fat) • carb. 9g • pro. 3g • fat 3g • sat. fat 1g
• chol. 27mg • sod. 168mg

Cuisinart® Crêpes

Makes sixteen crêpes (about 8 to 9-inch diameter)

- 1²/₃ cups warm water**
- 3 tablespoons softened butter, cut into 1-inch pieces**
- 1 cup unbleached, all-purpose flour**
- 3 large eggs**
- 1 teaspoon pure vanilla extract**
- ½ teaspoon salt**
- cooking spray**

Place first six ingredients, in order listed, in the Cuisinart® SmartPower Duet® blender jar (not cooking spray). Place cover on blender jar. Turn blender on and blend on Mix for 10 seconds. Turn blender off. Scrape blender jar with a spatula. Turn blender on and continue blending on Mix until smooth, about 5 to 10 seconds. Turn blender off.

Refrigerate in a covered container for 2 hours before using. Store in an airtight container in the refrigerator for up to 2 days. Stir well before using.

Coat a 9½-inch nonstick skillet with cooking spray, and place over medium heat. Pour 3 tablespoons batter into skillet, and swirl to coat bottom of the pan evenly with a thin film. Cook about 1 minute on each side, or until lightly browned.

Reserve crêpes. Repeat with remaining batter, coating pan with cooking spray as necessary.

Serve with creamed chicken, fresh berries or sautéed apples.

Nutritional information per crêpe:
Calories 59 (46% from fat) • carb. 6g • pro. 2g • fat 3g • sat. fat 2g
• chol. 46mg • sod. 107mg

Honey Wheat Waffles

Makes six waffles (about 3 cups batter)

- 1½ cups milk**
- 2 large eggs**
- ¾ cup plus 2 tablespoons unbleached, all-purpose flour**
- ½ cup whole-wheat flour**
- 4 tablespoons butter, melted**
- 2 tablespoons honey**
- 1 teaspoon baking powder**
- 1 teaspoon pure vanilla extract**
- ½ teaspoon salt**
- ¼ teaspoon baking soda**

Preheat waffle iron. Place ingredients in the Cuisinart® SmartPower Duet® blender jar in order listed. Place cover on blender jar. Turn blender on and blend on Purée for 10 seconds. Turn blender off. Scrape blender jar with spatula. Turn blender on and continue blending on Purée until smooth, about 10 to 15 seconds. Turn blender off. Follow waffle iron manufacturer's instructions to bake waffles.

Nutritional information per waffle:
Calories 239 (41% from fat) • carb. 28g • pro. 7g • fat 11g • sat. fat 6g
• chol. 96mg • sod. 419mg

SOUPS

Cold Gazpacho

Makes five 6-ounce servings

- 2 cups tomato juice, divided**
- 1 rib celery, peeled, cut into 1-inch pieces**
- 1 medium cucumber, peeled, seeds removed, cut in half lengthwise and into 1-inch pieces**
- 1 garlic clove, peeled, cut into 4 pieces**
- ½ medium green bell pepper, cored, seeded, cut into 1-inch pieces**
- 1 small jalapeño pepper, seeds removed, cut in half and into ¼-inch pieces**
- 4 scallions, cut into 1-inch pieces**
- 2 medium tomatoes, seeds removed, each cut into 8 pieces**
- 2 tablespoons lemon juice**
- ¼ teaspoon black pepper**

Place 1 cup tomato juice in Cuisinart® SmartPower Duet® blender jar. Add celery and next six ingredients. Place cover on blender jar. Turn blender on and blend on Purée until vegetables are medium-finely chopped, about 10 to 15 seconds. Turn blender off.

Place in a large serving bowl, and add remaining 1 cup tomato juice, lemon juice, and pepper; stir to combine. Chill before serving.

Nutritional information per serving:
Calories 85 (11% from fat) • carb. 16g • pro. 3g • fat 1g • sat. fat 0g
• chol. 0mg • sod. 511mg

Cream of Asparagus Soup

Makes eight 6-ounce servings

- ¾ cup parsley leaves**
- 3 tablespoons butter or margarine**
- 1 small onion, cut into 1-inch pieces**
- ¾ pound asparagus, trimmed, cut into 1-inch pieces**
- 3 cups chicken stock or broth**
- 1 cup half-and-half**
- 3 teaspoons cornstarch**
- 1½ cups cold water**
- salt and white pepper, to taste**

Place parsley in Cuisinart® SmartPower Duet® blender jar. Place cover on blender jar. Turn blender on and pulse on Purée until coarsely chopped, about 4 to 5 times. Turn blender off. Reserve.

Melt butter in a medium saucepan over medium heat. Add onion, and cook until soft but not brown, about 2 to 3 minutes. Add asparagus, stock, and all but 1 tablespoon of reserved parsley. Cover; bring to a boil over medium-high heat. Reduce heat to low and cook, partially covered, until asparagus is tender, about 10 to 12 minutes.

Drain vegetables, being sure to reserve the cooking liquid. Allow cooking liquid to cool 5 minutes. Add 1 cup of the cooking liquid and half of the solids, in order listed, to the blender jar. Place cover on blender jar. Turn blender on and blend on Food Processor speed until smooth, about 25 to 30 seconds. Turn blender off. Return the puréed vegetable mixture to the saucepan. Repeat with remaining 1 cup liquid and vegetables. Add remaining cooking liquid and half-and-half to puréed vegetables in the saucepan; stir to combine. Stir cornstarch into water, and add to soup. Cook, stirring often, over medium heat, until soup thickens, about 6 to 8 minutes. Do not boil. Adjust seasonings to taste; garnish with remaining parsley, and serve.

Nutritional information per serving:
Calories 112 (64% from fat) • carb. 7g • pro. 3g • fat 8g • sat. fat 5g
• chol. 23mg • sod. 610mg

Potato-Leek Soup

Makes four 6-ounce servings

- 1 tablespoon unsalted butter**
- 2 medium leeks, whites only, sliced horizontally and cut into 1-inch pieces**
- 1 small onion, cut into 1-inch pieces**

- 2 medium potatoes, peeled, cut into 1-inch pieces**
- 1¾ cups reduced-sodium chicken broth**
- ½ cup water**
- ½ teaspoon salt**
- ¼ teaspoon white pepper**
- 3 tablespoons chopped chives (optional)**

Melt butter in a medium saucepan over medium heat. Add leeks and onion; sauté until soft but not brown, about 5 to 8 minutes; stir occasionally. Add potatoes, broth, and water; cover; bring to a boil over medium-high heat. Reduce heat to low, and simmer, uncovered, until potatoes are soft, about 10 to 15 minutes.

Drain vegetables, being sure to reserve the cooking liquid. Allow cooking liquid to cool 5 minutes. Add half of the cooking liquid and half of the solids to Cuisinart® SmartPower Duet® blender jar. Place cover on blender jar. Turn blender on and blend on Food Processor speed until smooth, about 15 to 20 seconds. Turn blender off. Return the puréed vegetable mixture to the saucepan.

Repeat with remaining liquid and vegetables and return vegetable mixture to saucepan. Add salt and pepper; stir to combine. Garnish with chopped chives, if desired.

Nutritional information per serving:
Calories 208 (17% from fat) • carb. 38g • pro. 5g • fat 4g • sat. fat 1g
• chol. 0mg • sod. 380mg

Creamy Cantaloupe Soup

Makes five 6-ounce servings

- ½ cup orange juice**
- 1 medium cantaloupe, seeds and peel removed, cut into 1-inch pieces**
- 1 cup plain nonfat yogurt**
- 2 tablespoons sugar***
- 2 tablespoons Port (optional)**
- 2 tablespoons fresh mint leaves**

Place orange juice and cantaloupe in Cuisinart® SmartPower Duet® blender jar. Place cover on blender jar. Turn blender on and blend on Purée until smooth, about 20 to 25 seconds. Add yogurt, sugar, and Port (if using). Blend on Purée until smooth, about 15 seconds. Turn blender off. Serve chilled. Garnish with mint leaves.

*Use less sugar if the cantaloupe is naturally sweet.

Nutritional information per serving:
Calories 96 (0% from fat) • carb. 20g • pro. 4g • fat 0g • sat. fat 0g
• chol. 1mg • sod. 45mg

Corn Chowder

Makes seven 6-ounce servings

- 1** **tablespoon unsalted butter**
- 1** **medium leek, white only, washed, cut into 1-inch pieces**
- 1** **medium onion, cut into ¼-inch pieces**
- 2** **celery ribs, peeled, cut into ¼-inch pieces**
- 1** **medium potato (about 9 ounces), peeled, cut into ½-inch pieces**
- 1²/₃** **cups reduced-sodium chicken broth**
- 1** **bay leaf**
- ¼** **teaspoon dried thyme**
- 1¹/₃** **cups reduced fat milk**
- 2** **cups corn kernels (fresh or frozen; thaw if frozen)**
- salt and pepper to taste**

Melt butter in a medium saucepan over medium heat. Add leek and onion; cook over medium heat for 3 minutes. Add celery, and sauté until soft, about 2 minutes. Add potato, broth, bay leaf, and thyme. Cover; bring to a boil over medium-high heat. Reduce heat to low, and cook, partially covered, until potato is tender, about 8 to 10 minutes.

Place milk and 1 cup corn in Cuisinart® SmartPower Duet® blender jar. Place cover on blender jar. Turn blender on and blend on Food Processor speed until well combined, about 25 to 30 seconds. Turn blender off. Add milk mixture and remaining corn to saucepan. Season with salt and pepper, if desired. Cook gently over low heat until heated through. Remove bay leaf before serving.

Nutritional information per serving:

*Calories 208 (17% from fat) • carb. 36g • pro. 7g • fat 4g • sat. fat 2g
• chol. 8mg • sod. 290mg*

DESSERTS

Espresso Granita

Makes six ½ cup servings

- 2** **cups hot espresso**
- ½** **cup sugar**
- 1** **cup chilled coffee**

Combine espresso and sugar in a small bowl until sugar dissolves. Pour into ice cube trays, and freeze until solid, about 8 hours. Place chilled coffee and 10 espresso cubes in Cuisinart® SmartPower Duet® blender jar. Place cover on blender jar. Turn blender on and blend on Food Processor speed until thick, about 20 to 30 seconds. Turn blender off. Add remaining ice cubes. Turn blender on and blend until thick, about 20 seconds. Turn blender off. Serve immediately in well chilled parfait cups. Top with a dollop of whipped cream.

Nutritional information per serving:

*Calories 68 (0% from fat) • carb. 17g • pro. 0g • fat 0g • sat. fat 0g
• chol. 0mg • sod. 1mg*

Fresh Lemon Granita

Makes eight ½ cup servings

- 2** **cups sugar**
- 2** **cups water**
- 1½** **cups fresh lemon juice (juice of about 6 lemons)**
- 1** **tablespoon grated lemon zest***

Combine sugar and water in a medium saucepan, and bring to a boil over medium-high heat. Reduce heat to low, and simmer until sugar dissolves, about 3 to 4 minutes. Cool completely.** When cool, add lemon juice and zest; stir to combine.

Pour into ice cube trays, and freeze until solid, about 8 hours. Place 10 frozen cubes in Cuisinart® SmartPower Duet® blender jar. Place cover on blender jar. Turn blender on and press Ice Crush button 10 times or until ice is the consistency of snow. Continue crushing 10 cubes at a time until all are crushed. Turn blender off. Spoon into well chilled parfait cups and serve immediately.

*Zest is the colored part of the citrus rind. Do not use the white pith. For best results, remove zest from the lemon with a vegetable peeler.

**Place mixture in a covered container, and store in the refrigerator overnight, or chill over an ice bath for 30 minutes.

Nutritional information per serving:

*Calories 216 (0% from fat) • carb. 54g • pro. 0g • fat 0g • sat. fat 0g
• chol. 0mg • sod. 1mg*

Lemon Ricotta Cheesecake with Raspberry Sauce

Makes eight servings (one 9-inch cheesecake)

- 3** **whole graham crackers**

- 1** **tablespoon cold butter, cut into 8 pieces**
- 2** **tablespoons sugar**
- 4** **strips lemon zest, cut in half**
- ½** **cup liquid egg substitute**
- 6** **tablespoons lemon juice**
- 30** **ounces part-skim ricotta cheese**
- ½** **cup sugar, divided**

Preheat oven to 325°F. Cover the outside of 9-inch springform pan with foil.

Break each graham cracker into 8 pieces and add to Cuisinart® SmartPower Duet® blender jar.

Place cover on blender jar. Turn blender on and blend on Mix until crushed, about 10 to 15 seconds. Add butter and 1 tablespoon sugar; blend on Mix until combined, about 10 to 15 seconds. Turn blender off. Press mixture into bottom of pan, and bake 10 minutes.

Add lemon zest and 1 teaspoon sugar to clean and dry blender jar. Place cover on blender jar. Turn blender on and blend on Food Processor speed for 15 to 20 seconds. Add egg substitute and remaining ingredients in the order listed; blend on Mix for 60 to 75 seconds. (It may look as if the ingredients are not mixing; however, the blender is working. After about 30 seconds, the mixture will start to circulate in the blender jar.) Turn blender off. Pour into prebaked crust, and bake until firm, about 1 hour. Cool completely on a wire rack, and then refrigerate at least 6 hours before serving. Serve with Raspberry Sauce (page 25).

Nutritional information per serving (cheesecake only):
Calories 251 (39% from fat) • carb. 24g • pro. 14g • fat 11g • sat. fat 6g
• chol. 37mg • sod. 211mg

Baked Almond Custard

Makes six servings

- 3** **large eggs**
- 1½** **cups reduced fat milk**
- 1** **cup evaporated fat-free milk**
- ½** **cup sugar**
- 1** **teaspoon pure almond extract**
- 6** **teaspoons finely chopped or slivered almonds**

Preheat oven to 325°F. Add first five ingredients to Cuisinart® SmartPower Duet® blender jar (not almonds). Place cover on blender jar. Turn blender on and blend on

Mix until combined, about 10 seconds. Turn blender off. Divide mixture among six 6-ounce ramekins or custard cups, filling each about ¾ full. Top each with 1 teaspoon almonds.

Place ramekins in a 9 x 13-inch baking dish and add hot water to reach 1 inch up the sides of the ramekins. Bake until a knife inserted in the center comes out clean, about 1 hour. Remove ramekins from water bath and cool on a wire rack. Cover and chill in the refrigerator before serving.

Nutritional information per serving:
Calories 181 (25% from fat) • carb. 25g • pro. 9g • fat 5g • sat. fat 2g
• chol. 112mg • sod. 111mg

FOOD PROCESSOR RECIPES

For use with the Cuisinart® SmartPower Duet® Food Processor only.

Before following any of these Cuisinart® recipes, make sure the SmartPower Duet® Blender/Food Processor is properly assembled. Follow the Assembly directions on page 10 of this instruction booklet for correct food processor assembly procedure.

Note: Always turn power base off prior to removing bowl cover.

Hummus

Makes 2¼ cups

- 2** **cups canned garbanzo beans, drained**
- ½** **cup fresh lemon juice**
- 4** **tablespoons tahini**
- 4** **garlic cloves, peeled**
- 1½** **tablespoons olive oil**
- 2** **teaspoons salt**
- parsley sprig**

Place first 6 ingredients in the Cuisinart® SmartPower Duet® food processor work bowl fitted with the chopping blade. Place cover on work bowl. Press the On button and process on food processor speed until smooth, about 30 to 40 seconds.

Press Off button. Transfer to a serving dish and garnish with parsley. Serve at room temperature.

Nutritional information per tablespoon:
Calories 40 (27% from fat) • carb. 6g • pro. 1g • fat 1g • sat. fat 0g
• chol. 0mg • sod. 69mg

Fresh Tomato Salsa

Makes 1 cup

- ¼ cup fresh cilantro leaves**
- 1 small garlic clove, peeled**
- 1 jalapeño pepper, halved, seeded, cut into ½-inch pieces**
- 1 small onion, cut into ¾-inch pieces**
- 3 plum tomatoes, cut into ½-inch pieces**
- 1 teaspoon fresh lime juice**
- 1 teaspoon salt**

Place cilantro in the Cuisinart® SmartPower Duet® food processor work bowl fitted with the chopping blade. Place cover on bowl and press the On button. With the food processor running on Food Processor speed, add garlic through the feed tube and process until finely chopped, about 5 seconds. Scrape work bowl. Add jalapeño, onion, tomatoes, lime juice and salt.

Press the Pulse button and pulse on Food Processor speed until coarsely chopped, about 8 to 10 times. Press Off button.

Nutritional information per tablespoon:

*Calories 20 (0% from fat) • carb. 4g • pro. 1g • fat 0g • sat. fat 0g
• chol. 0mg • sod. 271mg*

Spicy Crab Dip

Makes 1¾ cups

- 1 tablespoon fresh chives**
- 1 cup lowfat sour cream**
- ⅓ cup fat-free milk**
- ¼ cup lowfat mayonnaise**
- ½ teaspoons prepared horseradish**
- ¼ teaspoon ground white pepper**
- 1 can (6 ounces) crabmeat, drained (about ¾ cup)**

Place chives in the Cuisinart® SmartPower Duet® food processor work bowl fitted with the chopping blade. Place cover on work bowl and press the On button. Process on Food Processor speed until finely chopped, about 5 seconds. Leave in bowl. Add remaining ingredients to work bowl and press Pulse button. Pulse on Food Processor speed until combined, about 6 times. Press Off button. Refrigerate for 1 to 2 hours before serving to develop flavor.

Nutritional information per tablespoon:

*Calories 64 (53% from fat) • carb. 2g • pro. 2g • fat 2g • sat. fat 1g
• chol. 15mg • sod. 91mg*

Creamy Guacamole

Makes 1½ cups

- ¼ cup fresh cilantro leaves**
- 1 medium garlic clove, peeled**
- 1 small scallion, trimmed, cut into 1-inch pieces**
- ½ small green chili, seeded**
- ¼ teaspoon salt**
- ⅛ teaspoon chili powder**
- ½ cup nonfat plain yogurt**
- 2 tablespoons fresh lemon juice**
- 1 small plum tomato, cut into ½-inch pieces**
- 2 small ripe avocados, peeled, pits removed, cut into ½-inch pieces**

Place cilantro, garlic, scallion, chili, salt and chili powder in the Cuisinart® SmartPower Duet® food processor work bowl fitted with the chopping blade. Place cover on work bowl and press On button. Process on Food Processor speed until finely chopped, about 5 seconds. Scrape work bowl and add yogurt, lemon juice, tomato and avocados. Press Pulse button and pulse on Food Processor speed 5 times, then run continuously until smooth, about 20 seconds. Press Off button.

Tip: To prevent browning, bury avocado pit in the center of the mixture. Cover tightly and refrigerate.

Nutritional information per tablespoon:

*Calories 39 (69% from fat) • carb. 2g • pro. 1g • fat 3g • sat. fat 0g
• chol. 0mg • sod. 30mg*

Pesto

Makes eight 1-ounce servings

- 3 ounces Parmesan, cut into ¾-inch pieces**
- 3 small garlic cloves, peeled**
- 2 cups fresh basil leaves, loosely packed**
- ⅔ cup olive oil**
- ¼ cup pine nuts**

Place Parmesan in the Cuisinart® SmartPower Duet® food processor work bowl fitted with the chopping blade. Place the cover on the work bowl and press the On button. Process on Food Processor speed until finely chopped, about 45 seconds. Reserve. Add garlic and process until finely chopped, about 5 seconds. Scrape work bowl and add basil, oil and pine nuts. Process until combined, about 15 seconds.

Scrape work bowl and add reserved cheese. Process until well blended, about 30 seconds. Press Off button.

Nutritional information per serving:
Calories 262 (89% from fat) • carb. 2g • sod. 202mg • pro. 5g • fat 26g
• sat. fat 5g • chol. 8mg

Raspberry Sauce

Makes eight 1-ounce servings

- 12 ounces frozen raspberries, thawed, at room temperature (about 1¹/₃ cups)**
- 1 tablespoon sugar**

Place raspberries and sugar in the Cuisinart® SmartPower Duet® food processor work bowl fitted with the chopping blade. Place cover on work bowl and press On button. Process on Food Processor speed until well combined, about 20 seconds. Press Off button. Strain mixture through a fine sieve. Store in an airtight container in the refrigerator. Serve over fruit, ice cream, cake or cheese cake.

Nutritional information per serving:
Calories 52 (0% from fat) • carb. 13g pro. 0g • fat 0g • sat. fat 0g
• chol. 0mg • sod. 0mg

Classic Mayonnaise with Cooked Eggs

Heating eggs to 160°F for a moment kills salmonella bacteria.

Makes 1 cup

- 1 large egg**
- 1 large egg yolk**
- ½ teaspoon sugar**
- ½ teaspoon unbleached, all-purpose flour**
- 1 tablespoon white wine vinegar**
- 1¼ teaspoons dry mustard**
- ½ teaspoon salt**

- ¼ teaspoon freshly ground white pepper**
- ⅔ cup vegetable oil**

Have ready a pie plate filled with ice cubes and cold water. Add the whole egg, egg yolk, sugar and flour to the Cuisinart® SmartPower Duet® food processor work bowl fitted with the chopping blade. Place cover on work bowl and press On button. Process on Food Processor speed until combined, about 5 seconds. Transfer to a 7-inch nonstick skillet. Wash the work bowl, blade and lid with hot water and soap; dry.

Over medium heat, using a heatproof scraper, stir the egg mixture until it thickens to the consistency of a thin custard, about 1 to 1½ minutes. Stir ½ minute longer, then remove the pan from the heat and place it in the prepared ice water bath, stirring the egg mixture until it is cool.

Add the cooled egg mixture to the clean workbowl fitted with the chopping blade, along with the vinegar, dry mustard, salt and pepper. Process on Food Processor speed to blend, about 15 seconds. With the machine running, pour ⅓ cup of the oil into the pusher and let it drip through the small hole. The mayonnaise will thicken gradually. Remove the small pusher and add the remaining oil through the feed tube in a slow, steady stream, about 1 minute. Stop processing once all the oil has been added and the mixture is emulsified.

Variation: Cholesterol-Free Mayonnaise

Substitute ½ cup pasteurized liquid egg substitute for the egg and egg yolk. Omit the cooking/cooling steps.

Nutritional information per tablespoon of Classic Mayonnaise:
Calories 93 (96% from fat) • carb. 0g • pro. 1g • fat 10g • sat. fat 1g
• chol. 27mg • sod. 77mg

Low-Fat Blue Cheese Dressing

Makes 1 cup

- 1 cup fresh parsley**
- 1/3 cup fat-free milk**
- 1/2 cup nonfat plain yogurt**
- 2 ounces blue cheese, cut into ½-inch pieces**
- 1 tablespoon fresh lemon juice**
- 1 tablespoon balsamic vinegar**
- 1/4 teaspoon ground white pepper**
- 1/4 teaspoon salt**

Place parsley in the Cuisinart® SmartPower Duet® food processor work bowl fitted with the chopping blade. Place cover on work bowl and press On button. Process

on Food Processor speed until finely chopped, about 10 seconds. Add remaining ingredients and process until smooth, about 20 seconds. Press Off button. Store in the refrigerator in an airtight container for up to two weeks.

Nutritional information per tablespoon:
Calories 17 (53% from fat) • carb. 1g • prot. 1g • fat 1g • sat. fat 1g
• chol. 3mg • sod. 96mg

Whipped Cream

Makes 1 cup

- 1 cup whipping cream**
- 1 tablespoon sugar**
- 1 teaspoon pure vanilla extract**

Place cream in the Cuisinart® SmartPower Duet® food processor work bowl fitted with the chopping blade. Place cover on work bowl and press On button. Process on Food Processor speed until cream begins to thicken, about 30 seconds. Add sugar and vanilla. Continue processing until cream is thickened, about 30 seconds. Press Off button.

Nutritional information per tablespoon:
Calories 115 (86% from fat) • carb. 3g • pro. 1g • fat 11g • sat. fat 7g
• chol. 41mg • sod. 11mg

Chicken Stir-Fry

Makes 4 servings

- 1 pound boneless, skinless chicken breasts**
- 1 medium garlic clove, peeled**
- 1 1-inch piece fresh ginger, peeled**
- 2 small carrots, peeled, cut to fit feed tube horizontally**
- 4 ounces mushrooms, stems trimmed**
- 6 medium scallions, trimmed, cut into 1-inch pieces**
- 1 small zucchini, cut to fit feed tube vertically**
- 1 medium red pepper, cored, seeded, cut into rectangles to**

- 6 fit feed tube**
- 2 tablespoons vegetable oil, divided**
- 2 teaspoons cornstarch**
- 2 teaspoons cold water**
- ½ cup reduced sodium chicken broth**
- 2 tablespoons soy sauce**
- 1½ teaspoons sesame oil**
- freshly ground black pepper, to taste**

Cut chicken breasts in half. Roll each half into a cylinder and wrap in plastic wrap. Freeze until chicken is hard to the touch, but is still easily pierced with a sharp knife.

Place garlic and ginger in the Cuisinart® SmartPower Duet® Food processor work bowl fitted with the chopping blade. Place cover on the work bowl and press the On button. Process on Food Processor speed until minced, about 10 seconds. Remove and reserve. Insert the shredding disc. Pack carrots in the feed tube and shred. Remove and reserve. Insert the slicing disc and slice mushrooms, scallions, zucchini and pepper, reserving each separately. Slice semi-frozen chicken. Press Off button.

Heat oil in a stir-fry pan or large skillet over medium-high heat. Add 2 tablespoons vegetable oil and stir-fry chicken until it is cooked through and juices run clear. Cook chicken in batches if necessary. Reserve and keep warm. Add 2 tablespoons oil to stir-fry pan and cook garlic and ginger until fragrant, about 15 seconds. Add carrots and cook for 15 seconds. Add remaining vegetables and cook until *just* tender, about 1 minute. Remove and reserve.

Combine cornstarch and water in a small bowl. Add broth, soy sauce and sesame oil. Add to stir-fry pan and cook over medium-high heat until thickened, about 2 minutes. Add reserved chicken and vegetables; stir to combine and cook until heated through. Season to taste with pepper and serve immediately.

Nutritional information per serving:
Calories 380 (57% from fat) • carb. 12g • pro. 29g • fat 24g • sat. fat 3g
• chol. 66mg • sod. 803mg

Potatoes au Gratin

Makes 6 servings

- cooking spray**
- 1 small garlic clove, peeled**
- 1 cup heavy cream**
- ½ cup reduced-sodium, lowfat chicken broth**
- ¼ pound Cheddar**
- 4 medium potatoes, peeled, halved lengthwise, ends cut flat**
- salt to taste**
- freshly ground black pepper to taste**

Preheat oven to 375°F and spray a 9-inch square baking dish with vegetable oil cooking spray.

Place garlic in the Cuisinart® SmartPower Duet® food processor work bowl fitted with the chopping blade. Place cover on work bowl and press On button. Process on Food Processor speed until minced, about 5 seconds.

Place cream, broth and garlic in a small saucepan and bring to a simmer over medium-low heat.

Insert the shredding disc into the food processor work bowl and shred the cheese. Reserve. Insert the slicing disc and slice the potatoes. Press Off button.

Layer half the potato slices in the bottom of the prepared baking dish. Sprinkle with salt, pepper and half the cheese. Add remaining potatoes in a layer over the cheese, and season. Pour the hot cream mixture over the top of the potatoes.

Bake until potatoes are tender, liquid is absorbed and top is browned, about 1 hour. Sprinkle remaining cheese on top, 5 minutes before the end of cooking.

Nutritional information per serving:
Calories 361 (52% from fat) • carb. 34g • pro. 9g • fat 21g • sat. fat 13g
• chol. 74mg • sod. 302mg

Shredded Carrots and Zucchini

Makes 4 servings

- 2 small zucchini, trimmed, cut to fit feed tube**
- 3 medium carrots, peeled, cut to fit feed tube**
- 2 tablespoons unsalted butter**
- ¼ teaspoon salt**
- ½ teaspoon dried basil**
- freshly ground black pepper, to taste**

Insert the shredding disc in the Cuisinart® SmartPower Duet® food processor work bowl and place cover on work bowl. Press On button. Place zucchini in feed tube and shred, using Food Processor speed. Remove and reserve. Place carrots in feed tube and shred. Press Off button.

Melt butter in a medium skillet over medium heat. Add carrots and cook until tender, about 2 minutes. Add zucchini and seasonings. Cook, stirring often, until just tender, about 1 minute. Serve warm.

Nutritional information per serving:
Calories 86 (60% from fat) • carb. 8g • pro. 1g • fat 6g • sat. fat 4g
• chol. 16mg • sod. 141mg

Chicken Salad

Makes 2 servings

- 1 small celery stalk, peeled, cut into ¾-inch pieces**
- 1/3 small red pepper, cut into ¾-inch pieces**
- 1 cup cooked chicken, cut into ¾-inch pieces**
- 1/4 cup lowfat mayonnaise**
- salt to taste**
- freshly ground black pepper to taste**

Place celery and red pepper in the Cuisinart® SmartPower Duet® food processor work bowl fitted with the chopping blade. Place cover on work bowl, press On button and press Pulse button. Pulse on Food Processor speed until coarsely chopped, about 3 to 4 times. Add chicken and mayonnaise; pulse until combined, about 3 to 4 times. Press Off button. Season to taste with salt and pepper.

Nutritional information per serving:

*Calories 244 (59% from fat) • carb. 3g • pro. 22g • fat 16g • sat. fat 3g
• chol. 70mg • sod. 211mg*

Banana Walnut Muffins

Makes 6 muffins

- 1 cup unbleached, all-purpose flour**
- 1/4 cup sugar**
- 1½ teaspoons baking powder**
- 1/4 teaspoon cinnamon**
- 1/8 teaspoon salt**
- 1 small ripe banana, peeled, cut into 1-inch pieces**
- 1 large egg**
- 1/4 cup skim milk**
- 1/4 cup vegetable oil**
- 1/2 cup walnut halves**
- 1 teaspoon sugar**

Preheat oven to 375°F and line six muffin cups with paper liners.

Combine flour, sugar, baking powder, cinnamon and salt in a small bowl. Reserve.

Place banana pieces in the Cuisinart® SmartPower Duet® food processor work bowl fitted with the chopping blade. Place cover on work bowl and press On button.

Process on Food Processor speed until smooth, about 20 seconds. Scrape bowl. Add egg, milk and oil; process until combined, about 10 seconds. Add walnuts and dry

ingredients. Press Pulse button and pulse on Food Processor speed until flour is *just* mixed in, about 3 to 4 times. Batter will be lumpy and some dry flour may be left on top. Press Off button.

Fill prepared muffin cups with batter (fill almost to the top) and sprinkle tops with sugar. Bake until tops are lightly browned and a toothpick inserted in the center comes out clean, about 20 to 25 minutes. Remove from muffin pan and cool on wire rack.

Nutritional information per muffin:

*Calories 240 (45% from fat) • carb. 29g • pro. 4g • fat 12g • sat. fat 1g
• chol. 30mg • sod. 374mg*

Applesauce

Makes 1½ cups

- 1 pound apples, peeled, cored, cut into eighths**
- 1/4 cup water**

Place apples and water in a 2-quart saucepan over medium-low heat. Simmer until apples are soft, about 20 to 25 minutes. Add additional water, if necessary, to prevent burning. Remove from heat and allow apple mixture to cool before processing.

Transfer apple mixture to the Cuisinart® SmartPower Duet® food processor work bowl fitted with the chopping blade. Place cover on work bowl and press On button. Process on Food Processor speed until combined, about 15 seconds. Scrape work bowl. Process until smooth, about 10 to 15 seconds. Press Off button.

Nutritional information per ½ cup:

*Calories 84 (0% from fat) • carb. 21g • pro. 0g • fat 0g • sat. fat 0g
• chol. 0mg • sod. 1mg*

Tossed Salad

Makes 8 servings

- 8 cups assorted lettuces, washed, dried and torn into bite-sized pieces***
- 6 radishes, ends cut flat**
- 4 plum tomatoes, ends cut flat**
- 1 celery stalk, peeled, cut to fit feed tube vertically**
- 1 small red onion, peeled, ends cut flat**
- 1 medium carrot, peeled, cut to fit feed tube horizontally**
- 1 small zucchini, trimmed, cut to fit feed tube horizontally**
- 1 vinaigrette (recipe follows)**

Place lettuces in a large salad bowl. Insert the slicing disc in the Cuisinart® SmartPower Duet® food processor work bowl. Place cover on work bowl and press On button. Using Food Processor speed, slice radishes and transfer to salad bowl. Slice tomatoes, celery and red onion separately, transferring each to the salad bowl after slicing. Insert the shredding disc. Place carrots in feed tube horizontally and shred. Transfer to salad bowl. Repeat with zucchini. Press Off button. Toss vegetables with lettuces. When ready to serve, add vinaigrette and toss to combine.

*We recommend using a combination of romaine, Boston, red and green leaf lettuces.

Nutritional information per serving: (salad only)

*Calories 40 (0% from fat) • carb. 8g • pro. 2g • fat 0g • sat. fat 0g
• chol. 0mg • sod. 26mg*

Vinaigrette

Makes 1 cup

- 1 small garlic clove, peeled**
- 1/3 cup red wine vinegar**
- 1 tablespoon Dijon mustard**
- 1/2 teaspoon salt**
- 1/8 teaspoon freshly ground black pepper**
- 1 cup vegetable oil**

Place garlic in the Cuisinart® SmartPower Duet® food processor work bowl fitted with the chopping blade. Place cover on work bowl and press On button. Process on Food Processor speed until finely chopped, about 5 seconds. Add vinegar, mustard, salt and pepper; process 5 seconds to combine. With machine running, slowly pour oil through feed tube until well mixed, about 30 seconds. Press Off button.

Nutritional information per tablespoon:

*Calories 247 (98% from fat) • carb. 1g • pro. 0g • fat 27g • sat. fat 3g
• chol. 0mg • sod. 157mg*

WARRANTY LIMITED THREE-YEAR WARRANTY

This warranty is available to consumers only. You are a consumer if you own a Cuisinart® SmartPower Duet® Blender/Food Processor that was purchased at retail for personal, family or household use. Except as otherwise required under applicable law, this warranty is not available to retailers or other commercial purchasers or owners.

We warrant that your Cuisinart® SmartPower Duet® Blender/Food Processor will be free of defects in materials and workmanship under normal home use for 3 years from the date of original purchase.

We suggest you complete and return the enclosed product registration card promptly to facilitate verification of the date of original purchase. However, return of the product registration card does not eliminate the need for the consumer to maintain the original proof of purchase in order to obtain the warranty benefits. In the event that you do not have proof of purchase date, the purchase date for purposes of this warranty will be the date of manufacture.

If your Cuisinart® SmartPower Duet® Blender/Food Processor should prove to be defective within the warranty period, we will repair it, or if we think necessary, replace it. To obtain warranty service, simply call our toll-free number 1-800-726-0190 for additional information from our Customer Service Representatives, or send the defective product to Customer Service at Cuisinart, 150 Milford Road, East Windsor, NJ 08520.

To facilitate the speed and accuracy of your return, please enclose \$10.00 for shipping and handling of the product.

Please pay by check or money order (California residents need only supply proof of purchase and should call 1-800-726-0190 for shipping instructions).

NOTE: For added protection and secure handling of any Cuisinart® product that is being returned, we recommend you use a traceable, insured delivery service. Cuisinart cannot be held responsible for in-transit damage or for packages that are not delivered to us. Lost and/or damaged products are not covered under warranty. Please be sure to include your return address, daytime phone number, description of the product defect, product model number (located on bottom of product), original date of purchase, and any other information pertinent to the product's return.

CALIFORNIA RESIDENTS ONLY:

California law provides that for In-Warranty Service, California residents have the option of returning a nonconforming product (A) to the store where it was purchased or (B) to another retail store that sells Cuisinart® products of the same type.

The retail store shall then, at its discretion, either repair the product, refer the consumer to an independent repair facility, replace the product, or refund the purchase price less the amount directly attributable to the consumer's prior usage of the product. If the above two options do not result in the appropriate relief to the consumer, the consumer may then take the product to an independent repair facility if service or repair can be economically accomplished. Cuisinart and not the consumer will be responsible for the reasonable cost of such service, repair, replacement, or refund for nonconforming products under warranty.

California residents may also, according to their preference, return nonconforming products directly to Cuisinart for repair, or if necessary, replacement, by calling our Consumer Service Center toll-free at 1-800-726-0190. Cuisinart will be responsible for the cost of the repair, replacement, and shipping and handling for such products under warranty.

BEFORE RETURNING YOUR CUISINART® PRODUCT

If you are experiencing problems with your Cuisinart® product, we suggest that you call our Cuisinart® Service Center at 1-800-726-0190 before returning the product to be serviced. If servicing is needed, a Representative can confirm whether the product is under warranty and direct you to the nearest service location.

Your Cuisinart® SmartPower Duet® Blender/Food Processor has been manufactured to the strictest specifications and has been designed for use only in 120 volt outlets and only with authorized accessories and replacement parts. This warranty expressly excludes any defects or damages caused by attempted use of this unit with a converter, as well as use with accessories, replacement parts or repair service other than those authorized by Cuisinart. This warranty does not cover any damage caused by accident, misuse, shipment or other than ordinary household use. This warranty excludes all incidental or consequential damages. Some states do not allow the exclusion or limitation of these damages, so these exclusions may not apply to you. You may also have other rights, which vary from state to state.

Important: If the nonconforming product is to be serviced by someone other than Cuisinart's Authorized Service Center, please remind the servicer to call our Consumer Service Center at 1-800-726-0190 to ensure that the problem is properly diagnosed, the product is serviced with the correct parts, and the product is still under warranty.

©2019 Cuisinart
East Windsor, NJ 08520
Printed in China

19CE064750

Trademarks or service marks of third parties referred to
herein are the trademarks or service marks of their respective owners.

IB-9570-ESP-B