

INSIGNIA™

USER GUIDE

Air Purifier Large Room

NS-APLWH2



Before using your new product, please read these instructions to prevent any damage.

Contents

IMPORTANT SAFETY INSTRUCTIONS	3
Features	4
Package contents	4
Components	4
Control panel	5
Display	6
Before using your air purifier	7
Using your air purifier	9
Turning your air purifier on and off	9
Adjusting the fan speed	9
Setting the timer	9
Using Auto mode	9
Turning the child lock on or off	9
Understanding the filter indicator	9
Replacing the filter	10
Maintaining your air purifier	12
Troubleshooting	13
Specifications	13
Legal notices	14
ONE-YEAR LIMITED WARRANTY	15

IMPORTANT SAFETY INSTRUCTIONS

**WARNING:**

TO REDUCE THE RISK OF FIRE, ELECTRIC SHOCK OR INJURY:

- Use indoors only.
- Do not use for any purpose other than described in this user guide.
- Use only manufacturer's recommended accessories.
- Do not use with damaged cord or plug.
- If appliance is not working as it should, or has been dropped, damaged, left outdoors, or dropped into water, have it repaired at an authorized service center.
- Do not move or carry by cord, use cord as a handle, close a door on cord, or pull cord around sharp corners. Keep cord away from heated surfaces.
- Do not run cord under carpeting.
- Do not cover cord with throw rugs, runners or similar coverings. Do not route cord under furniture or appliances.
- Arrange cord away from traffic areas so it will not be tripped over.
- Do not unplug by pulling cord. To unplug, grasp the plug, not the cord.
- Do not handle plug or appliance with wet hands.
- This model is for household use only. Plastic film can be dangerous. To avoid danger of suffocation, keep away from children. Do not plug in your air purifier until you are familiar with all instructions and operating procedures. To reduce the risk of electrical shock, turn power switch off and disconnect polarized plug from electrical outlet BEFORE performing maintenance or troubleshooting checks.
- Do not put any object into openings. Do not use with any opening blocked; keep openings free of dust, lint, hair and anything that may reduce airflow. Keep hair, loose clothing and fingers away from openings. Turn OFF device controls before unplugging the appliance. Do not use appliance in an enclosed space filled with vapors given off by oil-based paint, paint thinner, moth-proofing substances, flammable dust or other explosive or toxic vapors. Keep appliance on a level surface. Do not immerse the unit in waters or other liquids, do not pour liquids into or around the unit or openings. Do not use the appliance near water or in a damp or wet location.
- This appliance has a polarized plug (one blade is wider than the other). To reduce the risk of electric shock, this plug is intended to fit in a polarized outlet only one way. If the plug does not fit fully in the outlet, reverse the plug. If it still does not fit, contact a qualified electrician. Do not attempt to defeat this safety feature.
- Do not use the appliance with any dimmer switch or solid state speed control device.

READ AND SAVE THESE INSTRUCTIONS

Features

- Designed for rooms measuring as large as 497 sq. ft. (46.1 sq. m)
- Captures 99% of particle pollution in the air, removing irritants and improving visibility
- HEPA filter removes allergens, mold, dust, pet dander, smoke, and pollen
- Carbon filter removes odors from chemicals like ammonia, formaldehyde, and nicotine
- Washable pre-filter removes large irritants such as hair and dander
- LED display shows you your current air quality level and filter life
- Four fan speeds (plus sleep mode) let you select how quickly air is purified
- Timer runs the purifier for a pre-set time (1, 2, 4, 8, or 12 hours), then automatically turns it off
- Child lock prevents accidental setting changes

Package contents





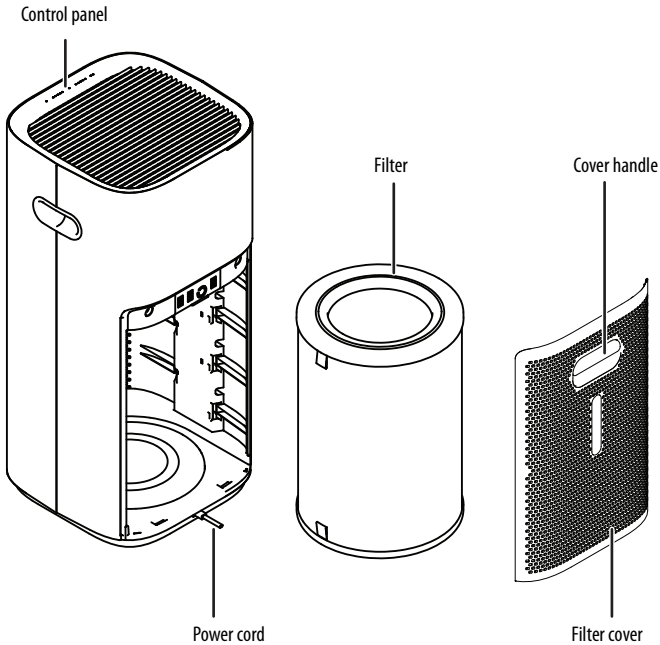

- Air Purifier Large Room
- Pre-filter/charcoal filter/HEPA air filter (combined and pre-installed)
- *User Guide*

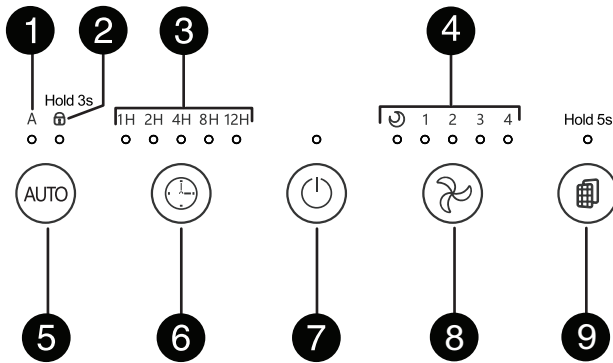
Components



Control panel



#	ITEM	DESCRIPTION
1	 (Auto mode indicator)	Lights when Auto mode is turned on.
2	 (child lock indicator)	Lights when the child lock is turned on.
3	Timer indicators	Light to show the selected turn-off time. See Setting the timer on page 9.
4	Fan speed indicators	Light to show how long the air purifier runs before turning off. See Adjusting the fan speed on page 9.
5	AUTO (Auto mode)	Press to turn Auto mode on or off. See Using Auto mode on page 9. Press and hold for three seconds to turn the child lock on or off. See Turning the child lock on or off on page 9.
6	 (timer)	Press to set the turn-off timer. See Setting the timer on page 9.
7	 (power)	Press to turn your air purifier on or off (standby mode). See Turning your air purifier on and off on page 9.
8	 (fan speed)	Press to select the fan speed. See Adjusting the fan speed on page 9.
9	 Filter reset button and filter replacement indicator	Press and hold to reset the filter replacement indicator. The indicator above the button turns off.

Display

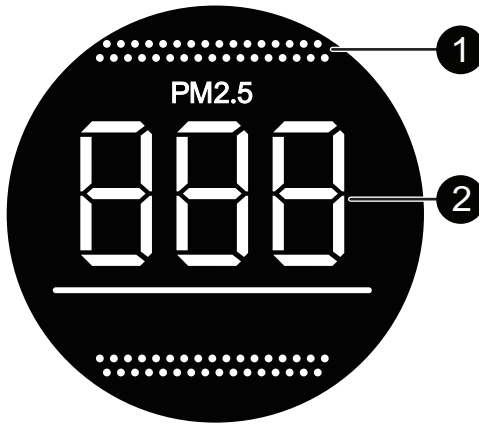

#	ITEM	DESCRIPTION
1	⋯⋯⋯⋯⋯⋯⋯ (air quality indicator)	Indicates the air quality. <ul style="list-style-type: none"> • Green—great • Yellow—okay • Orange—bad • Red—hazardous* *Proceed with caution and relocate to a less hazardous area and let the purifier run for at least 15 minutes.
2	Digital display	Shows the number of particles ≤ 2.5 micrometer in diameter.

Before using your air purifier

- 1 Remove all packaging materials from your air purifier, then place it on a level surface. Make sure that there are no obstructions to the air inlet or filtered air outlet.
- 2 Pull the filter cover handle out and up to remove the cover.

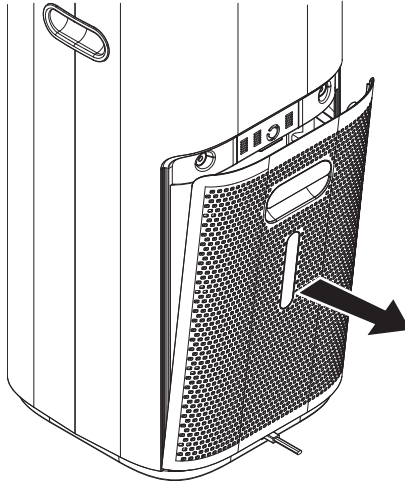

- 3 Remove the protective plastic bag from the filter.

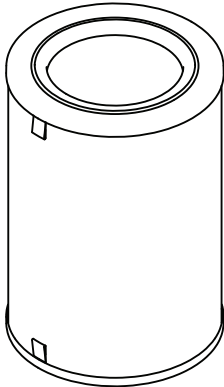

- 4 Place the filter into the purifier body.

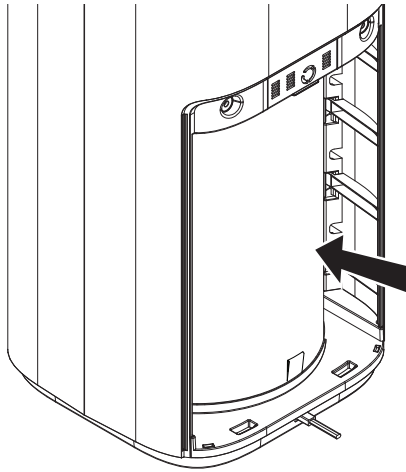

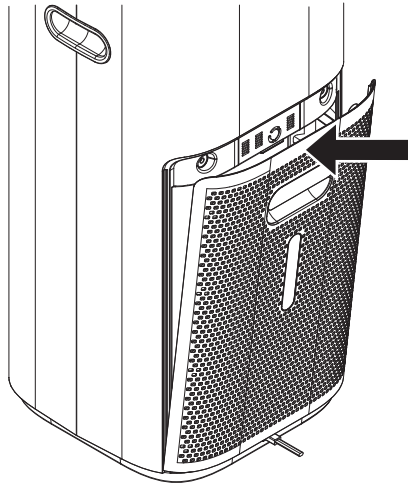

- 5 Insert the bottom of the filter cover into the purifier housing, then press the top of the cover to snap it into place.





Using your air purifier

Turning your air purifier on and off

- 1 Plug your air purifier power cord into a power outlet. Your air purifier enters standby mode, and a buzzer sounds once.
- 2 Press  (power) to turn your purifier on.
- 3 Press  again to turn off (standby mode) your purifier. A buzzer sounds to indicate the your air purifier is off.



Adjusting the fan speed

You can select the speed for the fan.

- 1 Make sure that your air purifier is turned on.
- 2 Press  (fan speed) on or more times to adjust the fan speed. You can select **1** (slow), **2** (medium), **3** (medium fast), **4** (fast), or Sleep mode. Each time your press , the speed indicator changes to match your selection.

Setting the timer

You can set a time when you want your air purifier to automatically turn off.

- 1 Make sure that your air purifier is turned on.
- 2 Press  (timer) to select a turn-off time. You can select **1H**, **2H**, **4H**, **8H**, or **12H**. Each time your press , the time indicator changes to match your selection. If you press  when **12H** is displayed, the timer turns off.

Using Auto mode

Auto mode adjusts the fan speed automatically according to the room's air quality.

- 1 Make sure that your air purifier is turned on.
- 2 Press the **A** (auto) to turn Auto mode on or off.

Turning the child lock on or off

The child lock prevents changes to settings.

- 1 Make sure that your air purifier is turned on.
- 2 Press and hold **AUTO** for three seconds to turn the child lock on.
- 3 Press and hold **AUTO** for three seconds again to turn the lock off.

Understanding the filter indicator

When the  flashes blue, you should replace the filter.

Replacing the filter

Filter life varies based on runtime and existing air conditions. We recommend that you replace the filter when the  (filter replacement) indicator starts flashing blue.

- 1 Turn off your air purifier, then unplug the power cord.
- 2 Use both hands to pull out the top edges of the filter cover toward you, then remove the cover.

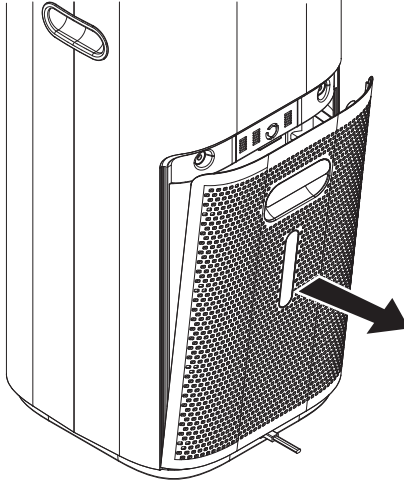

- 3 Pull the tabs on the top and bottom of the filter to remove it.

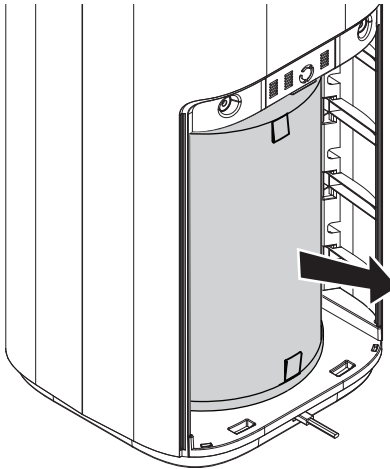

- 4 Remove the new filter from its plastic bag.

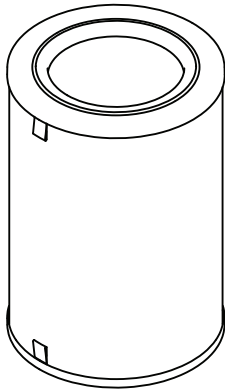

- 5 Insert the new filter into the purifier body.

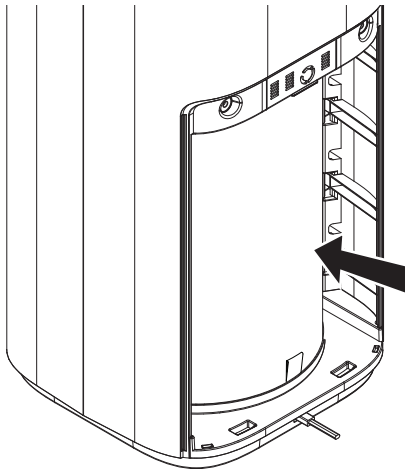

- 6 Insert the bottom of the filter cover into the purifier housing, then press the top of the cover forward to snap it into place.

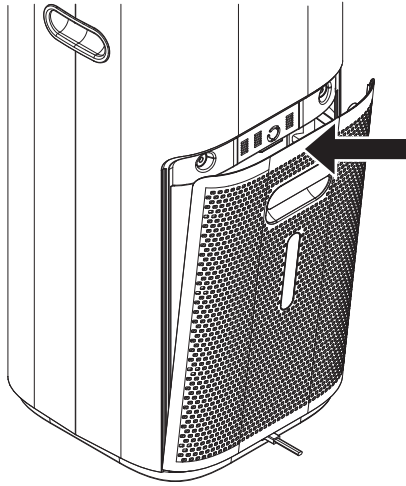

- 7 Press and hold  (filter reset) on the control panel for five seconds to reset the filter indicator.

Maintaining your air purifier

- 1 Turn your air purifier off, then unplug it.
- 2 Clean the outside of your purifier with a soft, clean, damp cloth.

CAUTION:

- Never wash the air filters.
- Do not put any part of your air purifier in a dishwasher.

- 3 Clean the filtered air inlet with a small, soft brush.

Troubleshooting

Note: If the included troubleshooting information doesn't solve a problem, contact Insignia Customer Support.

PROBLEM	SOLUTION
My air purifier doesn't work.	<ul style="list-style-type: none"> • Make sure that your air purifier is plugged in. • Make sure that the power outlet is working. • Make sure that your air purifier is turned on. • If your air purifier is plugged into a surge protector, make sure that the surge protector is turned on.
My air purifier has poor air flow or is loud.	<ul style="list-style-type: none"> • Make sure that your air purifier is on a flat surface. • Make sure that nothing is blocking the air inlet and filtered air cover. Position your air purifier at least 1 foot (.3 meters) away from walls or large objects. • Check the condition of the filter. Replace it if it's dirty. • Make sure that you remove the plastic bag from the filter. • Make sure that the filter is seated correctly.
My filter doesn't last the full lifetime.	<ul style="list-style-type: none"> • Excessive amounts of pet dander, dust, or smoke may decrease the life expectancy of the filter.
My filter indicator is flashing blue.	<ul style="list-style-type: none"> • When the filter indicator flashes blue, you need to check and replace your filter. See Replacing the filter on page 10.

Specifications

Dimensions (H×W×D)	26.5 × 12.2 × 12.5 in. (67.2 × 31 × 31.7 cm)
Weight	17.9 lbs. (8.1 kg)
Power input	120V AC
Power cord length	6 ft. (1.8 m)
Operating temperature	40~110°F (4~43°C)
Coverage area	497 ft. ² (46.1 m ²)
HEPA filter lifetime	Three months
HEPA filter dimensions (Height × Diameter)	14.6 (height) × 10 in. (diameter) (37.2 × 25.5 cm)
HEPA filter model number	NS-APFL2

**ENERGY STAR**

The energy efficiency of this ENERGY STAR qualified model is measured based on a ratio between the model's CADR for smoke and the electrical energy it consumes, or CADR'Watt.

Qualified model list: NS-APLWH2

Legal notices

FCC statement:

This device complies with part 15 of the FCC Rules. Operation is subject to the following two conditions:

(1) This device may not cause harmful interference, and (2) this device must accept any interference received, including interference that may cause undesired operation.

Changes or modifications not expressly approved by the party responsible for compliance could void the user's authority to operate the equipment.

Note: This equipment has been tested and found to comply with the limits for a Class B digital device, pursuant to part 15 of the FCC Rules. These limits are designed to provide reasonable protection against harmful interference in a residential installation.

This equipment generates, uses and can radiate radio frequency energy and, if not installed and used in accordance with the instructions, may cause harmful interference to radio communications. However, there is no guarantee that interference will not occur in a particular installation. If this equipment does cause harmful interference to radio or television reception, which can be determined by turning the equipment off and on, the user is encouraged to try to correct the interference by one or more of the following measures:

- Reorient or relocate the receiving antenna.
- Increase the separation between the equipment and receiver.
- Connect the equipment into an outlet on a circuit different from that to which the receiver is connected.
- Consult the dealer or an experienced radio/TV technician for help.

CAN ICES-3(B)/NMB-3(B)

ONE-YEAR LIMITED WARRANTY

Definitions:

The Distributor* of Insignia branded products warrants to you, the original purchaser of this new Insignia-branded product ("Product"), that the Product shall be free of defects in the original manufacturer of the material or workmanship for a period of one (1) year from the date of your purchase of the Product ("Warranty Period").

For this warranty to apply, your Product must be purchased in the United States or Canada from a Best Buy branded retail store or online at www.bestbuy.com or www.bestbuy.ca and is packaged with this warranty statement.

How long does the coverage last?

The Warranty Period lasts for 1 year (365 days) from the date you purchased the Product. Your purchase date is printed on the receipt you received with the Product.

What does this warranty cover?

During the Warranty Period, if the original manufacture of the material or workmanship of the Product is determined to be defective by an authorized Insignia repair center or store personnel, Insignia will (at its sole option): (1) repair the Product with new or rebuilt parts; or (2) replace the Product at no charge with new or rebuilt comparable products or parts. Products and parts replaced under this warranty become the property of Insignia and are not returned to you. If service of Products or parts are required after the Warranty Period expires, you must pay all labor and parts charges. This warranty lasts as long as you own your Insignia Product during the Warranty Period. Warranty coverage terminates if you sell or otherwise transfer the Product.

How to obtain warranty service?

If you purchased the Product at a Best Buy retail store location or from a Best Buy online website (www.bestbuy.com or www.bestbuy.ca), please take your original receipt and the Product to any Best Buy store. Make sure that you place the Product in its original packaging or packaging that provides the same amount of protection as the original packaging.

To obtain warranty service, in the United States and Canada call 1-877-467-4289. Call agents may diagnose and correct the issue over the phone.

Where is the warranty valid?

This warranty is valid only in the United States and Canada at Best Buy branded retail stores or websites to the original purchaser of the product in the country where the original purchase was made.

What does the warranty not cover?

- Food loss/spoilage due to failure of refrigerator or freezer
- Customer instruction/education
- Installation
- Set up adjustments
- Cosmetic damage
- Damage due to weather, lightning, and other acts of God, such as power surges
- Accidental damage
- Misuse
- Abuse
- Negligence
- Commercial purposes/use, including but not limited to use in a place of business or in communal areas of a multiple dwelling condominium or apartment complex, or otherwise used in a place of other than a private home.
- Modification of any part of the Product, including the antenna
- Display panel damaged by static (non-moving) images applied for lengthy periods (burn-in).
- Damage due to incorrect operation or maintenance

- Connection to an incorrect voltage or power supply
- Attempted repair by any person not authorized by Insignia to service the Product
- Products sold "as is" or "with all faults"
- Consumables, including but not limited to batteries (i.e. AA, AAA, C etc.)
- Products where the factory applied serial number has been altered or removed
- Loss or Theft of this product or any part of the product
- Display panels containing up to three (3) pixel failures (dots that are dark or incorrectly illuminated) grouped in an area smaller than one tenth (1/10) of the display size or up to five (5) pixel failures throughout the display. (Pixel based displays may contain a limited number of pixels that may not function normally.)
- Failures or Damage caused by any contact including but not limited to liquids, gels or pastes.

REPAIR REPLACEMENT AS PROVIDED UNDER THIS WARRANTY IS YOUR EXCLUSIVE REMEDY FOR BREACH OF WARRANTY. INSIGNIA SHALL NOT BE LIABLE FOR ANY INCIDENTAL OR CONSEQUENTIAL DAMAGES FOR THE BREACH OF ANY EXPRESS OR IMPLIED WARRANTY ON THIS PRODUCT, INCLUDING, BUT NOT LIMITED TO, LOST DATA, LOSS OF USE OF YOUR PRODUCT, LOST BUSINESS OR LOST PROFITS. INSIGNIA PRODUCTS MAKES NO OTHER EXPRESS WARRANTIES WITH RESPECT TO THE PRODUCT, ALL EXPRESS AND IMPLIED WARRANTIES FOR THE PRODUCT, INCLUDING BUT NOT LIMITED TO ANY IMPLIED WARRANTIES OF AND CONDITIONS OF MERCHANTABILITY AND FITNESS FOR A PARTICULAR PURPOSE, ARE LIMITED IN DURATION TO THE WARRANTY PERIOD SET FORTH ABOVE AND NO WARRANTIES, WHETHER EXPRESS OR IMPLIED, WILL APPLY AFTER THE WARRANTY PERIOD. SOME STATES, PROVINCES AND JURISDICTIONS DO NOT ALLOW LIMITATIONS ON HOW LONG AN IMPLIED WARRANTY LASTS, SO THE ABOVE LIMITATION MAY NOT APPLY TO YOU. THIS WARRANTY GIVES YOU SPECIFIC LEGAL RIGHTS, AND YOU MAY ALSO HAVE OTHER RIGHTS, WHICH VARY FROM STATE TO STATE OR PROVINCE TO PROVINCE.

Contact Insignia:

1-877-467-4289

www.insigniaproducts.com

INSIGNIA is a trademark of Best Buy and its affiliated companies.

*Distributed by Best Buy Purchasing, LLC

7601 Penn Ave South, Richfield, MN 55423 U.S.A.

©2021 Best Buy. All rights reserved.

INSIGNIA™

www.insigniaproducts.com

1-877-467-4289 (U.S. and Canada)

INSIGNIA is a trademark of Best Buy and its affiliated companies.

Distributed by Best Buy Purchasing, LLC

7601 Penn Ave South, Richfield, MN 55423 U.S.A.

©2021 Best Buy. All rights reserved.

V3 ENGLISH
21-0806