

INSIGNIA™

12-Cup Programmable Coffee Maker

NS-CMSS12



Before using your new product, please read these instructions to prevent any damage.

Insignia NS-CMSS12

12-Cup Programmable Coffee Maker

Contents

Important safeguards	2
Features	4
Package contents	5
Display	7
Function buttons	8
Pause and serve feature	9
Power cord storage feature.....	9
Unpacking and preparing your coffee maker.....	9
Setting the clock.....	11
Brewing coffee.....	11
Brewing a pot of coffee	11
Brewing one to four cups of coffee	13
Using delayed brewing.....	14
Maintenance.....	15
Cleaning your coffee maker	15
Storing your coffee maker.....	16
Specifications.....	16
One-year limited warranty - Insignia	17

Important safeguards

When using electrical appliances, especially when children are present, basic safety precautions should always be followed to reduce the risk of fire, electric shock, or injury to persons, including the following:

- 1 Read all instructions.
- 2 Do not touch hot surfaces. Use only handles or knobs.
- 3 To protect against fire, electrical shock, or injury to persons DO NOT immerse the power cord, plug, or your coffee maker in water or other liquids.
- 4 Close supervision is necessary when any appliance is used by or near children. For safety reasons, we recommend that children do not use your blender.
- 5 Unplug the power cord from the power outlet when not in use and before cleaning. Let your coffee maker cool before putting on or taking off parts and before cleaning.

- 6 Do not operate your coffee maker with a damaged power cord or plug, or after your coffee maker malfunctions or has been damaged in any manner. Return your coffee maker to the nearest authorized service facility for examination, repair, or adjustment.
- 7 The use of accessory attachments is not recommended because they may cause fire, electric shock, or injury.
- 8 Do not use outdoors.
- 9 Do not let the power cord hang over the edge of a table or counter or touch hot surfaces.
- 10 Do not place on or near a hot gas or electric burner, or in a heated oven.
- 11 Use extreme caution when moving your coffee maker if it contains hot coffee, water, or other liquids.
- 12 Do not use your coffee maker for other than its intended use.
- 13 To disconnect, turn off your coffee maker, then unplug the power cord from the electrical outlet.
- 14 The glass carafe is designed for use with this coffee maker. It must never be used on a range top. Do not set a hot carafe on a wet or cold surface. Do not use a cracked carafe or a carafe having a loose or weakened handle. Do not clean the carafe with cleansers, steel wool pads, or other abrasive materials. Do not place the carafe in a microwave oven.
- 15 The lid on the glass carafe must be closed for brewing.

SAVE THESE INSTRUCTIONS

Warning

To reduce the risk of fire or electric shock, do not remove the bottom cover. No user serviceable parts inside. Repair should be done by authorized service personnel only.

Your coffee maker is for HOUSEHOLD USE ONLY. It may be plugged into an AC power outlet (ordinary household current). Do not use any other power outlet.

DO NOT OPERATE YOUR COFFEE MAKER IF THE POWER CORD SHOWS ANY DAMAGE, OR IF YOUR COFFEE MAKER WORKS INTERMITTENTLY OR STOPS WORKING ENTIRELY.

Polarized plug

Your coffee maker has a polarized plug (one blade is wider than the other). To reduce the risk of electric shock, this plug is intended to fit into a polarized outlet only one way. If the plug does not fit fully into the outlet, reverse the plug and try again. If it still does not fit, contact a qualified electrician. Do not attempt to modify the plug in any way.

Power cord safety tips

A short power-supply cord is provided to reduce the risk of becoming entangled in or tripping over a longer cord. Longer, detachable power-supply cords or extension cords are available and may be used if care is exercised in their use. If a longer, detachable power-supply cord or extension cord is used:

- The marked electrical rating of the cord set or extension cord should be at least as great as the electrical rating of coffee maker.
- The cord should be arranged so that it does not drape over the counter top or tabletop where it can be pulled on by children or tripped over unintentionally.
- Never pull or yank on the power cord or your coffee maker.
- To insert the plug, grasp it firmly and guide it into the outlet.
- To disconnect your coffee maker, grasp the plug and remove it from the outlet.
- Before each use, inspect the line cord for cuts or abrasion marks. If any are found, this indicates that your coffee maker should be serviced and the power cord replaced.
- Never wrap the power cord tightly around your coffee maker, as this could place undo stress on the cord where it enters the appliance and cause the cord to fray and break.

Features

- 12-cup glass carafe
- Automatic pause and serve feature
- Keep warm mode
- Delayed brew mode
- Two-hour automatic shut-off
- Multiple brew functions
- Coffee filter

Package contents

- Coffee maker
- Filter basket
- Coffee filter
- Glass carafe
- Carafe lid
- *User Guide*

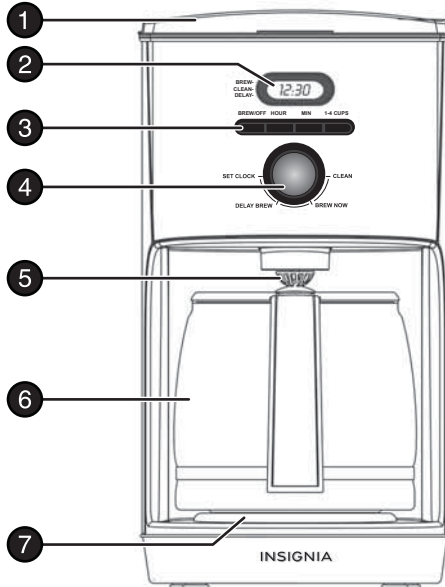

#	Item	#	Item
1	Flip-top brew basket	5	Pause and serve control
2	Display	6	12-cup glass carafe
3	Function buttons	7	Non-stick warming plate
4	Function selection dial		

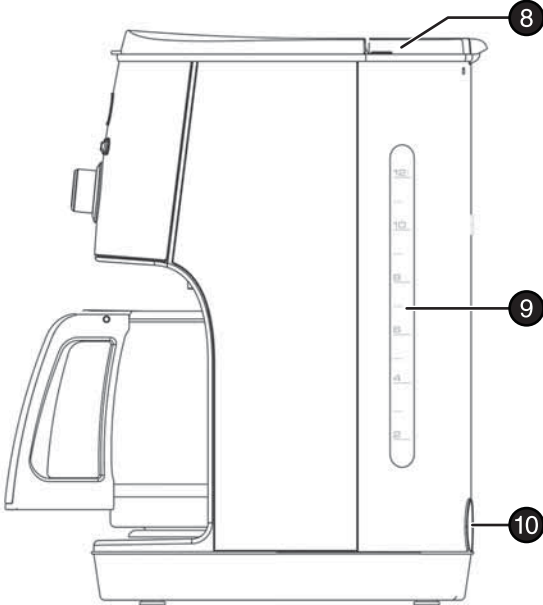

#	Item	#	Item
8	Water reservoir lid	10	Power cord storage compartment (on the back)
9	Full-view water level window		

Display

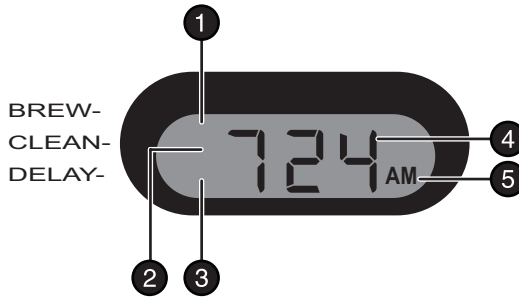

#	Item	Description
1	Brew indicator	Appears when your coffee maker is brewing coffee. See "Brewing coffee" on page 11.
2	Clean indicator	Appears when your coffee maker is in the cleaning cycle. See "Cleaning your coffee maker" on page 15.
3	Delay indicator	Appears when you have set a delay time and pressed the BREW/OFF button. See "Using delayed brewing" on page 14.
4	Current time	Displays the current time if you have set the clock. See "Setting the clock" on page 11.
5	AM/PM indicator	Displays AM if the time is before noon and PM is the time is after noon.

Function buttons

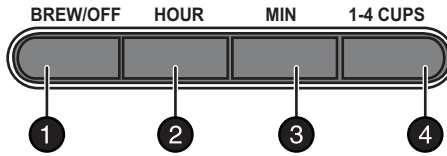

#	Item	Description
1	BREW/OFF	Press to start or stop brewing.
2	HOUR	Press to set the hour for the current time or delay brewing time. See "Setting the clock" on page 11 or "Using delayed brewing" on page 14.
3	MIN	Press to set the minutes for the current time or delayed brewing time. See "Setting the clock" on page 11 or "Using delayed brewing" on page 14.
4	1-4 CUPS	Press to brew one to four cups of coffee. See "Brewing one to four cups of coffee" on page 13.

Control dial

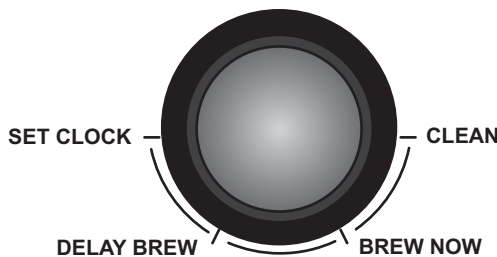

Turn the dial to:

- **SET CLOCK** to set the current time. See "Setting the clock" on page 11.
- **BREW NOW** to start brewing coffee. See "Brewing coffee" on page 11.
- **CLEAN** to start the cleaning cycle. See "Cleaning your coffee maker" on page 15.
- **DELAY BREW** to set up a delayed brewing time. See "Using delayed brewing" on page 14.

Pause and serve feature

You can pour a cup of coffee before the brewing cycle is complete.

When you remove the glass carafe during the brewing cycle, your coffee maker automatically pauses brewing so coffee does not drip onto the warming plate. When you replace the carafe, brewing starts again.

To use pause and serve, make sure that the carafe is in the correct position on the warming plate and at least one to two cups of coffee have been brewed.

Warning

To avoid spills, damage to your coffee maker, or burns, use the pause and serve feature as described.

Do NOT place a mug or cup directly under the coffee outlet.

Power cord storage feature

Your coffee has a power cord storage compartment on the back. You should store the power cord in the compartment when you are not using or you are storing your coffee maker.

Unpacking and preparing your coffee maker

Before you use your coffee maker for the first time, you need to clean it.

To unpack your coffee maker:

- 1 Carefully unpack your coffee maker and all its parts. Remove any tape, labels, or packaging materials.
- 2 Wash the filter basket, coffee filter, glass carafe, and carafe lid with warm, soapy water. Rinse well and dry thoroughly. Do not wash the parts in a dish washer.
- 3 Wipe the exterior surfaces of your coffee maker with a soft, moist cloth to remove dust particles collected during packing and handling. NEVER IMMERSER YOUR COFFEE MAKER, POWER CORD, OR PLUG IN WATER OR ANY OTHER LIQUID. Do not use harsh chemicals or abrasive cleaners on any part of your coffee maker.
- 4 Place your coffee maker on a solid, level, heat-resistant surface.

Preparing your coffee maker

To prepare your coffee maker:

- 1 Make sure that the filter basket and coffee filter are correctly seated and the lid on the filter basket is in the locked position. When the coffee filter is in place and the hinged lid is lowered, the filter is locked in position by the lid hinge.



- 2 Plug your coffee maker into a power outlet. The display flashes five times, then shows the clock.

Note

Ideally, your coffee maker should be operated on a separate circuit than other appliances.

- 3 Fill the glass carafe with cool water, then lift the water reservoir lid and pour the water into the reservoir.
- 4 Turn the control dial to **CLEAN**, then push the **BREW/OFF** button. The clean indicator appears on the display next to **CLEAN**. Your coffee maker cycles for five minutes. The display shows a count down of the cleaning time.

When the cleaning cycle is complete your coffee maker beeps twice.

Setting the clock

Setting the clock is optional, but you need to set the clock to use delayed brewing.

To set the clock:

- 1 Turn the control dial to **SET CLOCK**. The display flashes five times.
- 2 Press the **HOUR** button to set the hour. The display flashes. Each time you press the button, the hour increases by one and you hear a beep. You can also press and hold the button to quickly advance the hour.

Note

Note the AM or PM indicator as you set the hour.

- 3 Press the **MIN** button one or more times to set the minutes. The display flashes. Each time you press the button, you hear a beep. You can also press and hold the button to quickly advance the minutes.
- 4 After you set the time, wait three seconds. The display stops flashing and the time is set.
- 5 Turn the control dial away from the **SET CLOCK** position.

Brewing coffee

Caution

To avoid damaging your coffee maker, always turn off your coffee maker and let it cool for at least 10 minutes before making a second pot of coffee

Brewing a pot of coffee

To brew a pot of coffee:

- 1 Set your coffee maker on a dry, level, heat-resistant surface.
- 2 Fill the glass coffee carafe to the maximum fill line with cool water, then lift the water reservoir lid and pour the water into the water reservoir.

Note

You can use less water based on the number of cups you want to brew.

If you want to brew one to four cups of coffee, follow the instructions in "Brewing one to four cups of coffee" on page 13.

- 3 Make sure that the filter basket and coffee filter are correctly seated and the lid on the filter basket is in the locked position. When the coffee filter is in place and the hinged lid is lowered, the filter is locked in position by the lid hinge.

Note

- You can use a #4 paper cone filter instead of the coffee filter.
- To remove the coffee filter, lift the lid to release the filter, then pull out the filter.



- 4 Add coffee to the coffee filter based on the coffee package instructions and the number of cups you are brewing.

- 5 Turn the function control button to **BREW NOW**, then press the **BREW/OFF** button once. The brew indicator appears on the display next to **BREW**. The brew cycle takes about 12 minutes.

When brewing is complete, your coffee maker beeps twice and switches to the keep warm mode. After two hours, your coffee maker automatically shuts off.

Note

If you press any buttons or turn the control dial while your coffee maker is brewing, your coffee maker stops the brewing cycle.

To restart, empty the carafe and empty and clean the coffee filter. Add fresh coffee to the filter. Check the reservoir's water level, then add water to the reservoir. Do not over-fill the reservoir.

Brewing one to four cups of coffee

To brew one to four cups of coffee:

- 1 Set your coffee maker on a dry, level, heat-resistant surface.
- 2 Fill the glass carafe to the "4" line with cool water, then pour the water into the water reservoir.
- 3 Make sure that the filter basket and coffee filter are correctly seated and the lid on the filter basket is in the locked position. When the coffee filter is in place and the hinged lid is lowered, the filter is locked in position by the lid hinge.

Note

You can use a #4 paper cone filter instead of the coffee filter.

- 4 Add coffee to coffee filter, increasing or decreasing the amount to suit your individual taste.
- 5 Turn the control dial to **BREW NOW**.

- 6 Press the **1-4 CUPS** button once, then press the **BREW/OFF** button once. The brew cycle begins, the brew indicator appears on the display next to **BREW**, and the **BREW/OFF** and **1-4 CUPS** buttons light. The brew cycle takes about 3 to 4 minutes.

When brewing is complete, your coffee maker beeps twice and switches to the keep warm mode. After two hours, your coffee maker automatically shuts off.

Note

If you press any buttons or turn the control dial while your coffee maker is brewing, your coffee maker stops the brewing cycle.

To restart, empty the carafe and empty and clean the coffee filter. Add fresh coffee to the filter. Check the reservoir's water level, then add water to the reservoir. Do not over-fill the reservoir.

Using delayed brewing

You can set up your coffee maker to brew at a later time.

Note

Your coffee maker saves the delayed start time. To use the same start time, complete the following task, but skip Step 3.

To check the stored time, turn the control dial to **DELAY BREW**.

To use delayed brewing:

- 1 Prepare your coffee maker by following the steps for adding water and coffee in "Brewing coffee" on page 11 or "Brewing one to four cups of coffee" on page 13.
- 2 Turn the control dial to **DELAY BREW**. The display screen flashes and the delay indicator appears on the display next to **DELAY**.
- 3 While the display is flashing, set the time you want your coffee to start brewing. Follow the steps in "Setting the clock" on page 11 for setting the hour and minutes.

Notes

- If the display returns to the current time before you enter the delay, press the **HOUR** or **MIN** button to continue setting the delay start time.
- If you have set a delay start time and the display shows the current time, you can press the **HOUR** or **MIN** button to check the delay start time.

- 4 When you have finished setting the delay start time, wait three seconds. The display returns to the current time.
- 5 For a full pot of coffee, press the **BREW/OFF** button. The delay indicator appears on the display next to **DELAY**, and the **BREW/OFF** button lights.

OR

For one to four cups, press the **1-4 CUPS** button, then press the **BREW/OFF** button. The delay indicator appears on the display next to **DELAY**, and the **BREW/OFF** and **1-4 CUPS** buttons light.

Your coffee maker will begin brewing at the set time. When brewing starts, the brew indicator appears on the display next to **BREW**. When brewing is complete, your coffee maker beeps twice and switches to the keep warm mode. After two hours, your coffee maker automatically shuts off.

Maintenance

Warning

Your coffee maker contains no user serviceable parts. Do not try to repair it yourself. See qualified service personnel if servicing is needed.

Cleaning your coffee maker

Note

You should clean your coffee maker on a regular basis to prolong the life of your coffee maker and to guarantee optimal brewing results.

To clean your coffee maker:

- 1 Empty the coffee filter and wipe out any remaining grounds with a damp cloth.
- 2 Fill the glass carafe with cool water, then pour the water into the water reservoir.
- 3 Turn the control dial to **CLEAN**, then push the **BREW/OFF** button. The clean indicator appears on the display next to **CLEAN**. Your coffee maker cycles for five minutes. The display shows a count down of the cleaning time.
When the cleaning cycle is complete your coffee maker beeps twice.
- 4 If a second cleaning cycle is needed, add water, turn the control dial away from **CLEAN**, then back to **CLEAN** and press the **BREW/OFF** button to start a second cycle.
- 5 Turn off your coffee maker and unplug from the power cord.

- 6 Wipe the outside surfaces of your coffee maker with a damp cloth and dry thoroughly. **Never** use harsh chemicals or abrasive cleaning pads. **Never** immerse your coffee maker in water or any other liquid. **Never** place your coffee maker under running water.
- 7 Remove the filter basket, coffee filter, and carafe and wash them in warm soapy water. Do not use harsh chemicals or abrasive cleaners. Do not wash the parts in a dish washer. Dry thoroughly before using again.

Storing your coffee maker

- Make sure that all parts are clean and dry before storing. Store your coffee maker in its box or in a clean, dry place.
- Never store your coffee maker while it is hot or wet.
- Never wrap the power cord tightly around your coffee maker. Insert the power cord in the storage compartment on back of your coffee maker.
- Always store your coffee maker in an upright position.

Specifications

Dimensions (H × W × D)	16.4 × 7.2 × 8.2 in. (41.7 × 18.3 × 20.8 cm)
Weight	7.9 lbs (3.6 kg)

One-year limited warranty - Insignia

Definitions:

The Distributor* of Insignia branded products warrants to you, the original purchaser of this new Insignia-branded product ("Product"), that the Product shall be free of defects in the original manufacturer of the material or workmanship for a period of one (1) year from the date of your purchase of the Product ("Warranty Period").

For this warranty to apply, your Product must be purchased in the United States or Canada from a Best Buy branded or Future Shop branded retail store or online at www.bestbuy.com, www.bestbuy.ca, or www.futureshop.ca and is packaged with this warranty statement.

How long does the coverage last?

The Warranty Period lasts for 1 year (365 days) from the date you purchased the Product. Your purchase date is printed on the receipt you received with the Product.

What does this warranty cover?

During the Warranty Period, if the original manufacture of the material or workmanship of the Product is determined to be defective by an authorized Insignia repair center or store personnel, Insignia will (at its sole option): (1) repair the Product with new or rebuilt parts; or (2) replace the Product at no charge with new or rebuilt comparable products or parts. Products and parts replaced under this warranty become the property of Insignia and are not returned to you. If service of Products or parts are required after the Warranty Period expires, you must pay all labor and parts charges. This warranty lasts as long as you own your Insignia Product during the Warranty Period. Warranty coverage terminates if you sell or otherwise transfer the Product.

How to obtain warranty service?

If you purchased the Product at a Best Buy or Future Shop retail store location, please take your original receipt and the Product to any Best Buy or Future Shop store. Make sure that you place the Product in its original packaging or packaging that provides the same amount of protection as the original packaging. If you purchased the Product from a Best Buy or Future Shop online web site (www.bestbuy.com, www.bestbuy.ca, or www.futureshop.ca), mail your original receipt and the Product to the address listed on the web site. Make sure that you put the Product in its original packaging or packaging that provides the same amount of protection as the original packaging.

To obtain warranty service, in the United States call 1-888-BESTBUY, Canada call 1-866-BESTBUY for Future Shop call 1-800-663-2275. Call agents may diagnose and correct the issue over the phone.

Where is the warranty valid?

This warranty is valid only in the United States and Canada at Best Buy or Future Shop branded retail stores or websites to the original purchaser of the product in the county where the original purchase was made.

What does the warranty not cover?

This warranty does not cover:

- Customer instruction/education
- Installation
- Set up adjustments
- Cosmetic damage
- Damage due to weather, lightning and other acts of God, such as power surges
- Accidental damage
- Misuse
- Abuse

- Negligence
- Commercial purposes/use, including but not limited to use in a place of business or in communal areas of a multiple dwelling condominium or apartment complex, or otherwise used in a place of other than a private home.
- Modification of any part of the Product, including the antenna
- Display panel damaged by static (non-moving) images applied for lengthy periods (burn-in).
- Damage due to incorrect operation or maintenance
- Connection to an incorrect voltage or power supply
- Attempted repair by any person not authorized by Insignia to service the Product
- Products sold "as is" or "with all faults"
- Consumables, including but not limited to batteries (i.e. AA, AAA, C etc.)
- Products where the factory applied serial number has been altered or removed
- Loss or Theft of this product or any part of the product
- Display panels containing up to three (3) pixel failures (dots that are dark or incorrectly illuminated) grouped in an area smaller than one tenth (1/10) of the display size or up to five (5) pixel failures throughout the display. (Pixel based displays may contain a limited number of pixels that may not function normally.)
- Failures or Damage caused by any contact including but not limited to liquids, gels or pastes.

REPAIR OR REPLACEMENT AS PROVIDED UNDER THIS WARRANTY IS YOUR EXCLUSIVE REMEDY FOR BREACH OF WARRANTY. INSIGNIA SHALL NOT BE LIABLE FOR ANY INCIDENTAL OR CONSEQUENTIAL DAMAGES FOR THE BREACH OF ANY EXPRESS OR IMPLIED WARRANTY ON THIS PRODUCT, INCLUDING, BUT NOT LIMITED TO, LOST DATA, LOSS OF USE OF YOUR PRODUCT, LOST BUSINESS OR LOST PROFITS. INSIGNIA PRODUCTS MAKES NO OTHER EXPRESS WARRANTIES WITH RESPECT TO THE PRODUCT, ALL EXPRESS AND IMPLIED WARRANTIES FOR THE PRODUCT, INCLUDING, BUT NOT LIMITED TO, ANY IMPLIED WARRANTIES OF AND CONDITIONS OF MERCHANTABILITY AND FITNESS FOR A PARTICULAR PURPOSE, ARE LIMITED IN DURATION TO THE WARRANTY PERIOD SET FORTH ABOVE AND NO WARRANTIES, WHETHER EXPRESS OR IMPLIED, WILL APPLY AFTER THE WARRANTY PERIOD. SOME STATES, PROVINCES AND JURISDICTIONS DO NOT ALLOW LIMITATIONS ON HOW LONG AN IMPLIED WARRANTY LASTS, SO THE ABOVE LIMITATION MAY NOT APPLY TO YOU. THIS WARRANTY GIVES YOU SPECIFIC LEGAL RIGHTS, AND YOU MAY ALSO HAVE OTHER RIGHTS, WHICH VARY FROM STATE TO STATE OR PROVINCE TO PROVINCE.

Contact Insignia:

For customer service please call 1-877-467-4289

www.insigniaproducts.com

*Distributed by Best Buy Purchasing LLC

7601 Penn Avenue South, Richfield, Minnesota, U.S.A. 55423-3645

© 2014 BBY Solutions, Inc.

All rights reserved. INSIGNIA is a trademark of BBY Solutions, Inc. Registered in some countries. All other products and brand names are trademarks of their respective owners.

INSIGNIA™

www.insigniaproducts.com 1-877-467-4289 (U.S. and Canada) or
01-800-926-3000 (Mexico)

INSIGNIA is a trademark of Best Buy and its affiliated companies.

Registered in some countries.

Distributed by Best Buy Purchasing, LLC

7601 Penn Ave South, Richfield, MN 55423 U.S.A.

©2014 Best Buy. All rights reserved.

Made in China

V1 ENGLISH
14-0531