

# **Shark** VERTEX™

**DuoClean® PowerFins  
Powered Lift-Away®  
with Self-Cleaning Brushroll  
Upright Vacuum**

AZ2000 Series

**OWNER'S GUIDE**

---



**duo** clean *POWERFINS*

# IMPORTANT SAFETY INSTRUCTIONS

## HOUSEHOLD USE ONLY

To reduce the risk of electric shock, this vacuum cleaner has a polarized plug (one blade is wider than the other). As a safety feature, this plug will fit into a polarized outlet only one way. If the plug does not fit fully into the outlet, reverse the plug. If it still does not fit, contact a qualified electrician. **DO NOT** force into outlet or try to modify to fit.

## **⚠** WARNING

TO REDUCE THE RISK OF FIRE, ELECTRIC SHOCK OR INJURY:

### GENERAL WARNINGS

When using an electrical appliance, basic precautions should always be followed, including the following:

1. Your vacuum cleaner may consist of a motorized nozzle, wand, hose, and/or vacuum pod. This device contains electrical connections, electrical wiring, and moving parts that potentially present risk to the user.
2. Use only identical replacement parts.
3. Carefully observe and follow the instructions provided below to avoid improper use of the appliance. **DO NOT** use the vacuum for any purpose other than those described in this manual.
4. Before use, carefully inspect all parts for any damage. **DO NOT** use if any parts are damaged.
5. The use of an extension cord is **NOT** recommended.
6. This vacuum cleaner contains no serviceable parts.

### USE WARNINGS

7. This appliance can be used by persons with reduced physical, sensory or mental capabilities or lack of experience and knowledge if they have been given supervision or instruction concerning use of the appliance in a safe way and understand the hazards involved. Cleaning and user maintenance shall not be made by children. Keep the appliance and its cord out of reach of

children. **DO NOT** allow the appliance to be used by children. **DO NOT** allow to be used as a toy. Close supervision is necessary when used near children.

8. Always turn off the vacuum cleaner before connecting or disconnecting any motorized nozzles or other accessories.
9. **DO NOT** handle plug or vacuum cleaner with wet hands.
10. **DO NOT** use without filters in place.
11. Only use Shark® branded filters and accessories.
12. **DO NOT** damage the power cord:
  - a) **DO NOT** pull or carry vacuum cleaner by the cord or use the cord as a handle.
  - b) **DO NOT** unplug by pulling on cord. Grasp the plug, not the cord.
  - c) **DO NOT** run the vacuum cleaner over the power cord, close a door on the cord, pull the cord around sharp corners, or leave the cord near heated surfaces.
13. **DO NOT** put any objects into nozzle or accessory openings. **DO NOT** use with any opening blocked; keep free of dust, lint, hair, and anything that may reduce airflow.
14. **DO NOT** use if nozzle or accessory airflow is restricted. If the air paths or the motorized floor nozzle become blocked, turn the vacuum cleaner off and unplug from electrical outlet. Remove all obstructions before you plug in and turn on the unit again.

# SAVE THESE INSTRUCTIONS

## READ ALL INSTRUCTIONS BEFORE USE

15. Keep nozzle and all vacuum openings away from hair, face, fingers, uncovered feet, or loose clothing.
16. **DO NOT** use if vacuum cleaner is not working as it should, or has been dropped, damaged, left outdoors, or dropped into water.
17. Use extra care when cleaning on stairs.
18. **DO NOT** leave the vacuum cleaner unattended while plugged in.
19. When powered on, keep the vacuum cleaner moving over the carpet surface at all times to avoid damaging the carpet fibers.
20. **DO NOT** place vacuum cleaner on unstable surfaces such as chairs or tables.
21. Your Shark® vacuum may not be designed to stand up on its own. When taking a break from cleaning, you may need to lean it against furniture or a wall, or lay it flat on the floor. Using the vacuum for an application where the unit lacks stability may result in personal injury.
22. **DO NOT** use to pick up:
  - a) Liquids
  - b) Large objects
  - c) Hard or sharp objects (glass, nails, screws, or coins)
  - d) Large quantities of dust (drywall dust, fireplace ash, or embers). **DO NOT** use as an attachment to power tools for dust collection.
  - e) Smoking or burning objects (hot coals, cigarette butts, or matches)
  - f) Flammable or combustible materials (lighter fluid, gasoline, or kerosene)
  - g) Toxic materials (chlorine bleach, ammonia, or drain cleaner)
23. **DO NOT** use in the following areas:
  - a) Poorly lit areas
  - b) Wet or damp surfaces
  - c) Outdoor areas
  - d) Spaces that are enclosed and may contain explosive or toxic fumes or vapors (lighter fluid, gasoline, kerosene, paint, paint thinners, mothproofing substances, or flammable dust)
24. Turn off all controls before plugging in or unplugging the vacuum.
25. Unplug from electrical outlet when not in use and before any maintenance or cleaning.
26. Hand wash with water only. Washing with cleaning chemicals could damage the unit.
27. During cleaning or routine maintenance, **DO NOT** cut anything other than hair, fibers, or string wrapped around the brushroll.
28. Allow all filters to air-dry completely before replacing in the vacuum to prevent liquid from being drawn into electric parts.
29. Make sure the dust cup and all filters are in place after routine maintenance.
30. If provided, secure the power cord around the two cord hooks during storage.

## ASSEMBLY

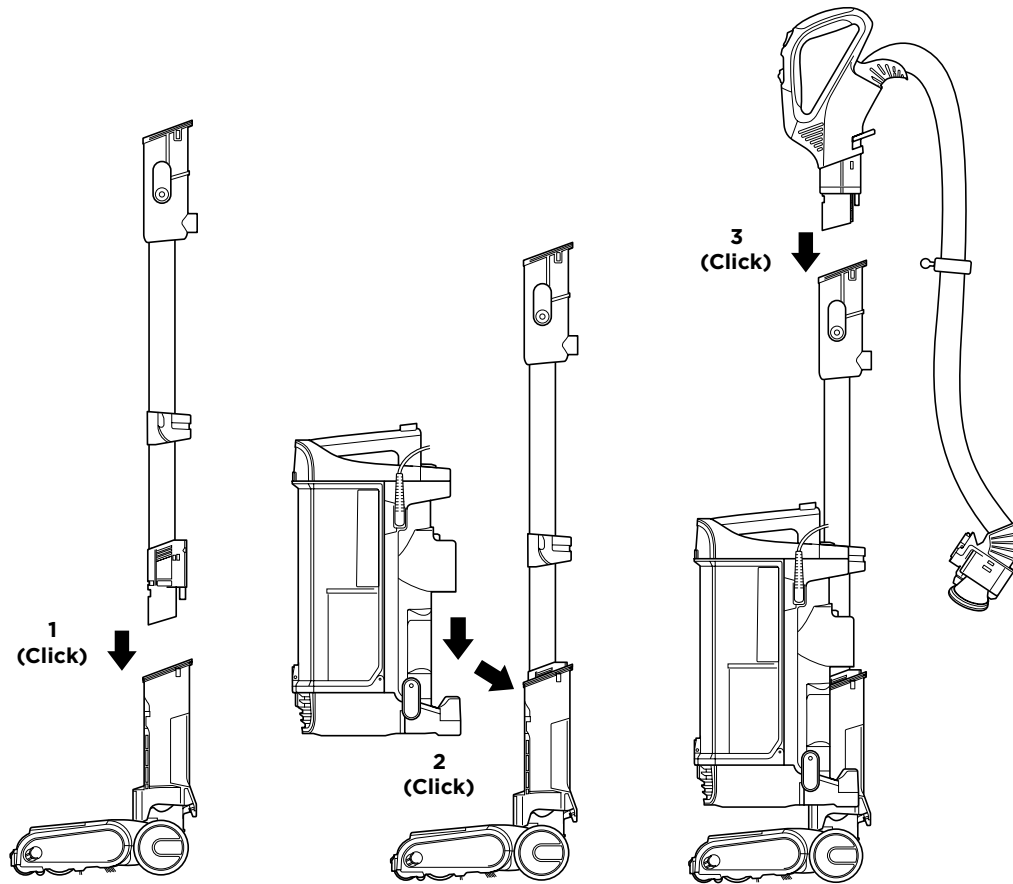

1. Place motorized **Nozzle** on floor and insert **Wand**, pressing it in until it clicks securely into place.
2. Place **Pod** onto wand and slide down to connect.
3. Insert **Handle** into wand, pressing it in until it clicks securely into place.
4. Connect **Hose** to back of pod, pressing it in until it clicks securely into place.
5. Store included accessories on the **Accessory Posts** on the pod.

**IMPORTANT:** For proper operation, ensure all connections are securely clicked into place.

## ASSEMBLY

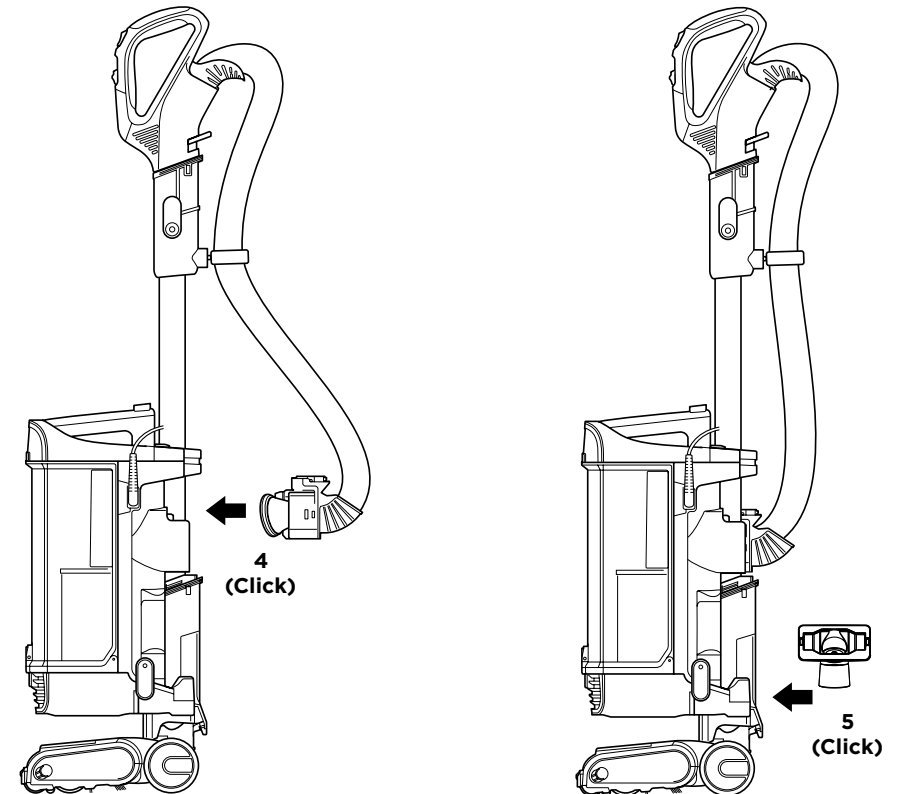

## WHOLE-HOME CLEANING

### SETTINGS

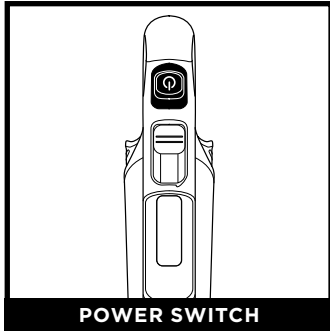

**POWER SWITCH**

Press power button to turn on vacuum. Please note the brushrolls will not spin unless the wand is reclined.

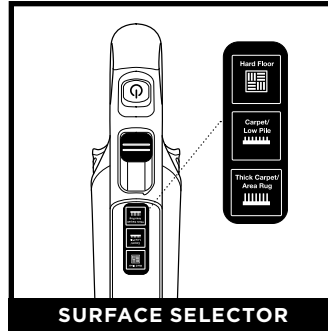

**SURFACE SELECTOR**

#### **Thick Carpet & Area Rug Cleaning**

Slide the surface switch to the top position to select Thick Carpet/Area Rug.

#### **Carpet & Low Pile Cleaning**

Slide the surface switch to the middle position to select Carpet/Low Pile to increase the speed of the brushrolls and to help remove stuck-on dust and debris.

#### **Hard Floor Cleaning**

Slide the surface switch to the bottom position to select Hard Floor.

**NOTE:** Try using Hard Floor mode for low pile area rugs.

### BRUSHROLL INDICATOR LIGHT

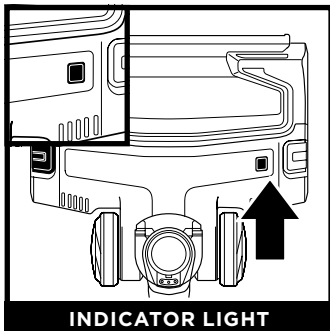

**INDICATOR LIGHT**

#### **WHAT DOES THE BRUSHROLL INDICATOR LIGHT MEAN?**

**Solid Green:** The brushrolls are spinning and working as they should.

**Solid Red:** There is a jam in the brushroll area. Turn off the vacuum and unplug it, then remove any blockages in the nozzle.

**Flashing Red:** The motorized floor nozzle is overheating. Turn off the vacuum, unplug it, and remove any blockages. Let the vacuum cool down for at least 60 minutes before restarting. See Troubleshooting section for more information.

**NOTE:** For deep cleaning per ASTM F 608 (embedded dirt in carpets) please set to **Carpet/Low Pile**.  
**NOTE:** For maximum suction for above-floor cleaning per ASTM F558, set to **Hard Floor** mode.

## WHOLE-HOME CLEANING

### CLEANING MODES

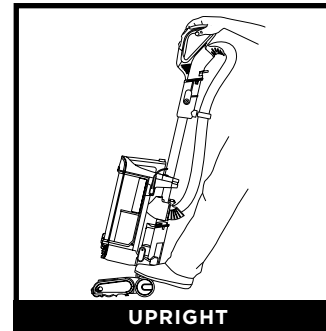

**UPRIGHT**

To engage brushrolls, step on floor nozzle and tilt handle back.

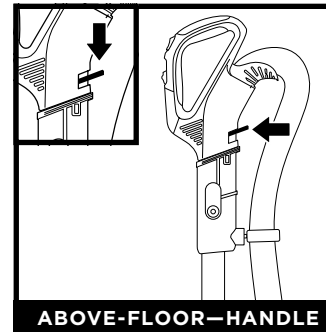

**ABOVE-FLOOR—HANDLE**

Press the **Handle Release** latch to detach the handle from the wand.

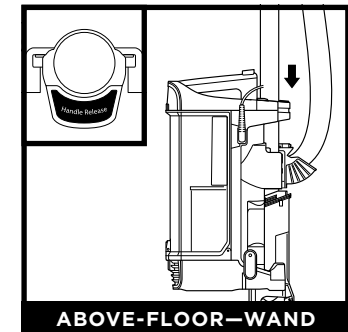

**ABOVE-FLOOR—WAND**

Press the **Wand Release** button to detach the wand from the pod.

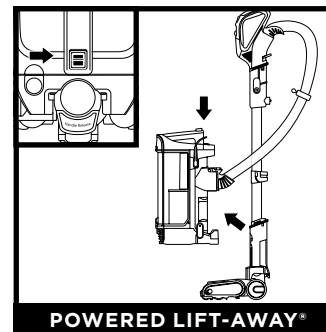

**POWERED LIFT-AWAY®**

Press the **Lift-Away** button to detach the pod from the floor nozzle.

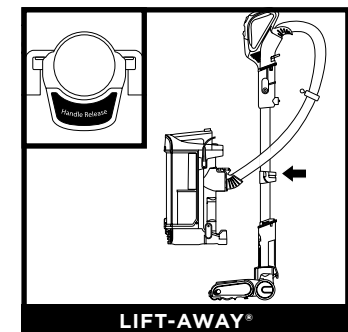

**LIFT-AWAY®**

With pod removed, press the **Wand Release** button to detach the wand from the floor nozzle.

**NOTE:** All accessories are compatible with both the wand and the handle.

## EMPTYING THE DUST CUP

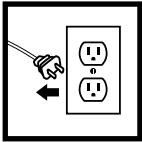

**IMPORTANT:** Unplug the power cord before performing any maintenance.

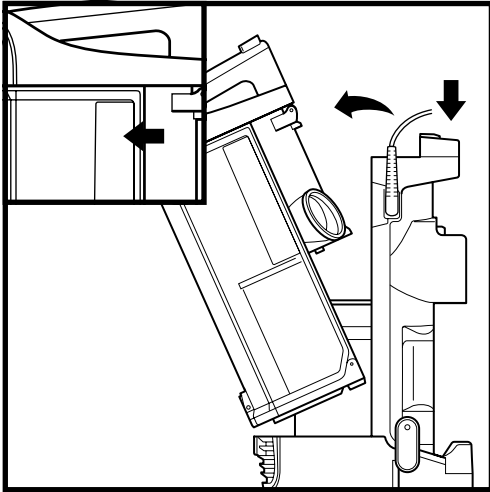

To remove **Dust Cup**, press release button on top of the pod. Tilt dust cup away from wand, then lift to remove.

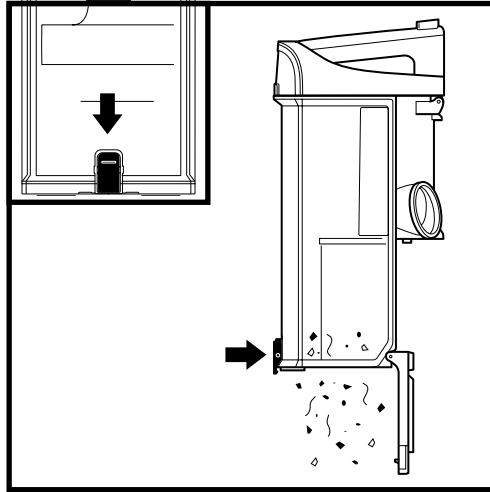

To empty debris into trash, press lower release button and bottom of dust cup will drop open.

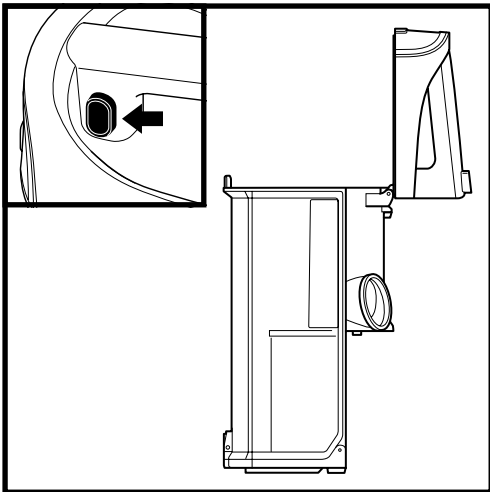

To remove collected debris from **Lint Screen**, press top release button and lift handle to access screen.

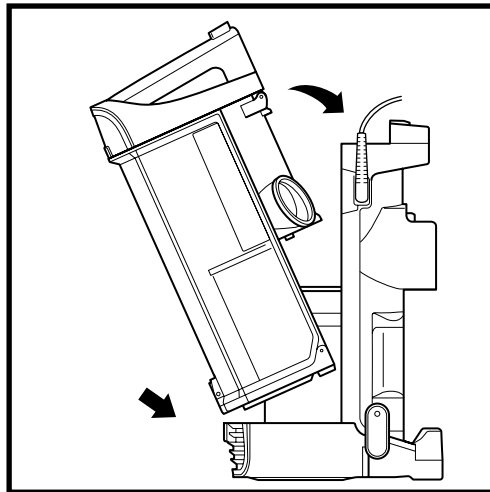

To reinstall, place bottom of dust cup into pod and then tilt until it clicks into place.

## CLEANING AND REPLACING THE FILTERS

### CLEANING FILTERS

**Regularly rinse and replace the filters to maintain your vacuum's suction power.**

To prevent damage from cleaning chemicals, rinse filters with cold water only. Allow all filters to air-dry for at least 24 hours before reinstalling them to prevent liquid from being drawn into electric parts.

**IMPORTANT: DO NOT** use soap when cleaning the filters.

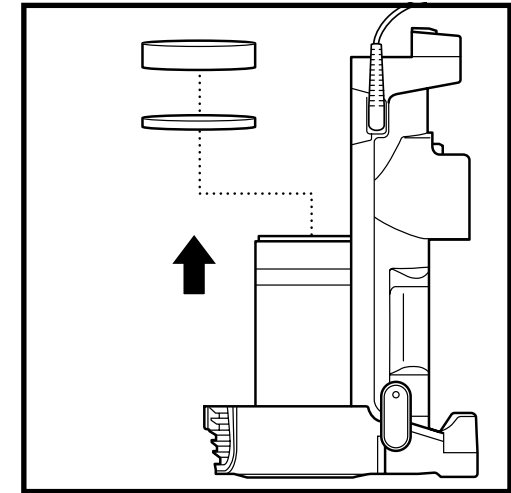

CLEAN PRE-MOTOR FILTERS EVERY MONTH

Remove **Dust Cup**, then lift out **Filters**.

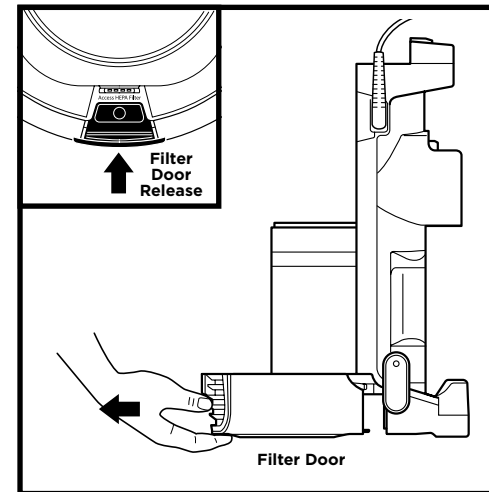

CLEAN HEPA FILTER EVERY YEAR

With the dust cup removed, press button on **Filter Door**. Pull forward and slide out to remove, then take out **HEPA Filter**.

To reinstall, insert HEPA filter into unit and replace filter door.

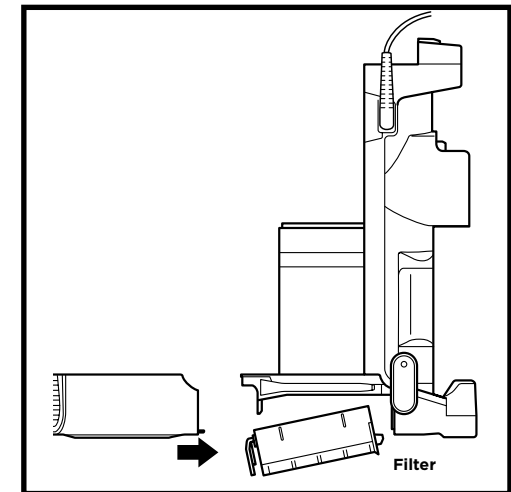

**NOTE:** The pre-motor filters should be replaced every 2.5 years. The post-motor filter should be replaced every 3 years.

## MAINTENANCE

### NOZZLE MAINTENANCE

#### SELF-CLEANING BRUSHROLL

If any hair is wrapped around the brushroll, continue vacuuming, using Carpet/Low Pile mode on a bare floor surface, a low-pile carpet, or a small area rug. This will allow the self-cleaning brushroll to remove the hair wrap and send it to the dust cup.

If you run over a hard or sharp object or notice a noise change while vacuuming, check for blockages or objects caught in the brushroll.

If some fibers remain wrapped around the brushroll after continued use, clear them from the brushroll.

#### CLEANING THE SOFT ROLLER

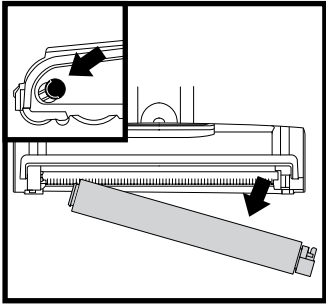

Slide the Soft Roller access button forward to release the Soft Roller.

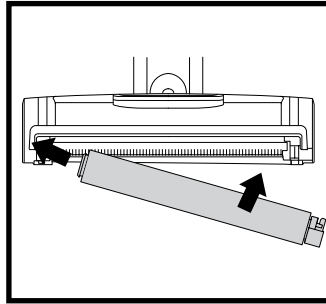

Hand wash the Soft Roller as needed. Use only water, and allow it to air-dry completely for at least 24 hours. Reinsert the Soft Roller in the front of the nozzle until it clicks into place.

## CHECKING FOR BLOCKAGES

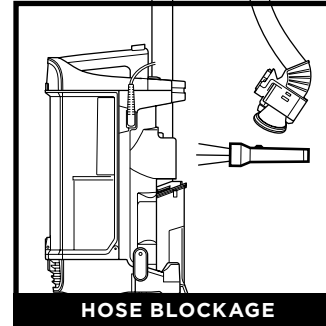

**HOSE BLOCKAGE**

Detach hose from vacuum pod, and check hose and opening on back of pod for blockages.

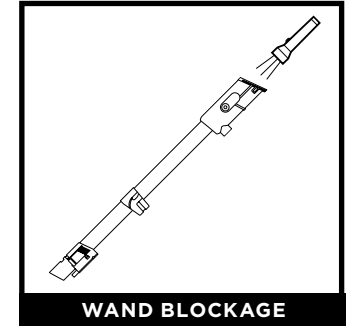

**WAND BLOCKAGE**

Detach wand from floor nozzle and handle, and check both ends for blockages.

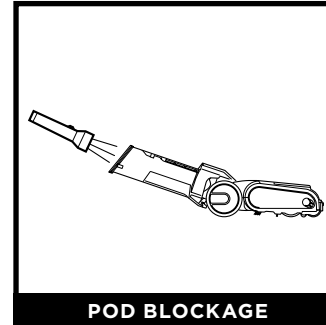

**POD BLOCKAGE**

Detach wand from floor nozzle, tilt nozzle neck back, and check opening for blockages.

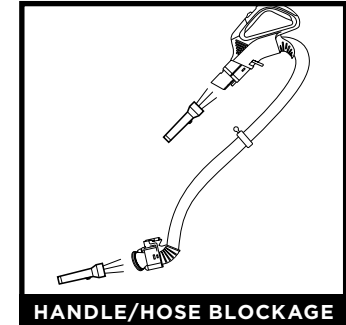

**HANDLE/HOSE BLOCKAGE**

Detach handle from wand and hose from the vacuum pod, and check openings for blockages.

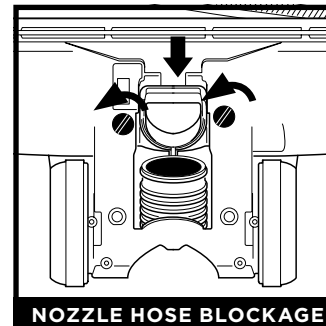

**NOZZLE HOSE BLOCKAGE**

To access the nozzle hose, open the locks on the bottom of the nozzle. With a coin, turn the locks counterclockwise, then lift the cover and clear any blockages.

## AVAILABLE ACCESSORIES

### A Crevice Tool

This slender tool offers extended reach to access corners, baseboards, tight spaces, and ceilings.

### B Upholstery Tool

Picks up hair, dust, and large debris from mattresses, couches, curtains, lampshades, and other delicate upholstered fabrics.

### C Pet Multi-Tool

A single convertible tool for cleaning tough pet messes two ways: use the stiff bristle brush to clean stuck-on debris, or take off the bristles to reveal an upholstery tool perfect for removing stubborn pet hair and large piles of debris.

### D Duster Crevice Tool

Two cleaning tools in one. The crevice tool gives you extended reach to clean in tight spaces, while the soft brush is ideal for dusting delicate surfaces.

### E Pet Power Brush

The turbine brush loosens and removes pet hair and debris from carpets, and powerfully deep-cleans dander out of upholstery and other surfaces.

### F Under-Appliance Wand

Clean under and behind hard-to-move appliances and furniture with this adjustable 36" tool. Flip the extension piece over to clean the underside of appliances.

### G Anti-Allergen Dust Brush

This brush features nylon fiber bristles specifically designed for removing fine dust and allergen particles from the most delicate surfaces.

### H Self-Cleaning Pet Power Brush

Tackles pet hair and ground-in dirt from above-floor areas like carpeted stairs and upholstery, while actively removing hair wrap as it cleans.

### I Home & Car Detail Kit

Deep-clean your car like a professional detailer, or clean hard-to-reach areas in your home. Micro-sized tools let you clean around delicate objects and access the tightest spaces like car vents and computer keyboards.

### J Accessory Bag

This convenient accessory storage bag measures 32 cm x 70 cm and fits the Under-Appliance Wand. Smaller size available at [sharkaccessories.com](http://sharkaccessories.com).

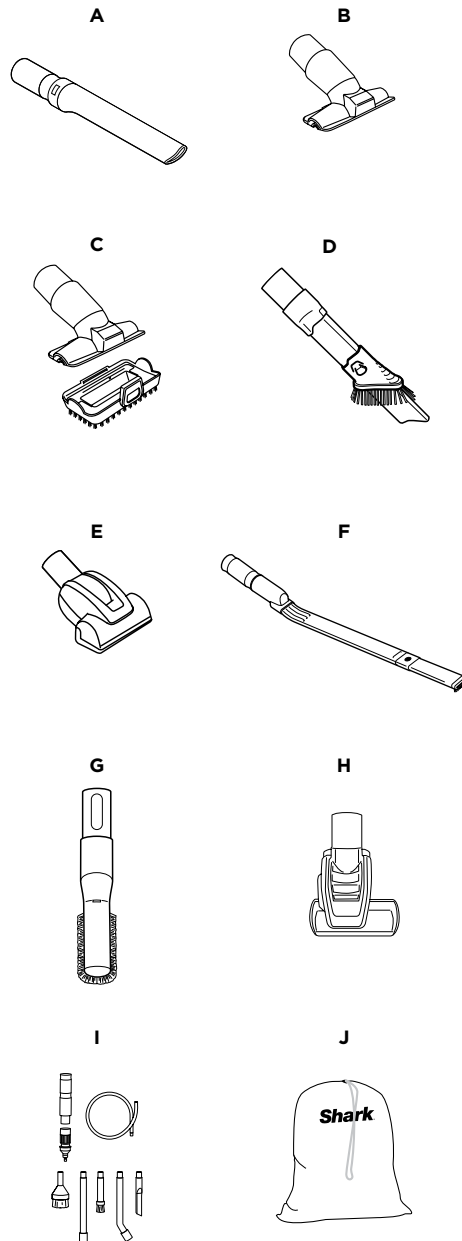

**NOTE:** Not all accessories come with all units. For a list of the accessories included with this model, see the top inside flap of the box. To order additional accessories, visit [sharkaccessories.com](http://sharkaccessories.com).

## TROUBLESHOOTING

### Vacuum is not picking up debris. No suction or light suction.

- Check filters to see if they need cleaning. Follow instructions for rinsing and air-drying the filters before reinstalling them.
- Dust cup may be full; empty dust cup.
- Check hose, hose connections, nozzle, wand, pod, and accessories for blockages. Clear any blockages found. See Checking for Blockages section for more information.
- If any hair, string, or carpet fibers are wrapped around the brushroll, extend cleaning time to allow the self-cleaning brushroll to remove them. If some hair or fibers remain wrapped around brushroll after continued use, carefully remove them. See Cleaning the Brushroll section for more information.

### Vacuum lifts area rugs.

- Make sure Surface Selector switch is set to Hard Floor.
- Suction is powerful. Take care when vacuuming area rugs or rugs with delicately sewn edges.

### Brushrolls do not spin.

- If the Brushroll Indicator Light turns red, immediately turn off and unplug the vacuum. Remove pod and wand from floor nozzle and clear any blockages. Reconnect nozzle, plug in vacuum, and turn on power.
- With the power on, recline the handle, which will automatically turn on the brushrolls.

### Vacuum turns off on its own or indicator light flashes red.

If your vacuum overheats, the thermostat will automatically turn off the motor. Perform the following steps to restart:

1. Turn vacuum off and unplug it.
2. Empty dust cup and clean filters. See Emptying the Dust Cup and Cleaning the Filters section for more information.
3. Check for blockages in hose, wand, floor nozzle, accessories, and inlet openings.
4. Allow unit to cool for a minimum of 60 minutes.
5. Plug in vacuum and turn it on.

For all other issues, please call Customer Service 1-800-798-7398.

## FIVE (5) YEAR LIMITED WARRANTY

The Five (5) Year Limited Warranty applies to purchases made from authorized retailers of **SharkNinja Operating LLC**. Warranty coverage applies to the original owner and to the original product only and is not transferable.

SharkNinja warrants that the unit shall be free from defects in material and workmanship for a period of five (5) years from the date of purchase when it is used under normal household conditions and maintained according to the requirements outlined in the Owner's Guide, subject to the following conditions and exclusions:

### What is covered by this warranty?

1. The original unit and/or non-wearable parts deemed defective, in SharkNinja's sole discretion, will be repaired or replaced up to five (5) years from the original purchase date.
2. In the event a replacement unit is issued, the warranty coverage ends six (6) months following the receipt date of the replacement unit or the remainder of the existing warranty, whichever is later. SharkNinja reserves the right to replace the unit with one of equal or greater value.

### What is not covered by this warranty?

1. Normal wear and tear of wearable parts (such as foam filters, HEPA filters, pads, etc.), which require regular maintenance and/or replacement to ensure the proper functioning of your unit, are not covered by this warranty. Replacement parts are available for purchase at [sharkaccessories.com](http://sharkaccessories.com).
2. Any unit that has been tampered with or used for commercial purposes.
3. Damage caused by misuse (e.g., vacuuming up water or other liquids), abuse, negligent handling, failure to perform required maintenance (e.g., not cleaning the filters), or damage due to mishandling in transit.
4. Consequential and incidental damages.
5. Defects caused by repair persons not authorized by SharkNinja. These defects include damages caused in the process of shipping, altering, or repairing the SharkNinja product (or any of its parts) when the repair is performed by a repair person not authorized by SharkNinja.
6. Products purchased, used, or operated outside North America.

### How to get service

If your appliance fails to operate properly while in use under normal household conditions within the warranty period, visit [sharkclean.com/support](http://sharkclean.com/support) for product care and maintenance self-help. Our Customer Service Specialists are also available at **1-800-798-7398** to assist with product support and warranty service options, including the possibility of upgrading to our VIP warranty service options for select product categories. So we may better assist you, please register your product online at [registeryourshark.com](http://registeryourshark.com) and have the product on hand when you call.

SharkNinja will cover the cost for the customer to send in the unit to us for repair or replacement. A fee of \$24.95 (subject to change) will be charged when SharkNinja ships the repaired or replacement unit.



### How to initiate a warranty claim

You must call **1-800-798-7398** to initiate a warranty claim. You will need the receipt as proof of purchase. We also ask that you register your product online at [registeryourshark.com](http://registeryourshark.com) and have the product on hand when you call, so we may better assist you. A Customer Service Specialist will provide you with return and packing instruction information.

### How state law applies

This warranty gives you specific legal rights, and you also may have other rights that vary from state to state. Some states do not permit the exclusion or limitation of incidental or consequential damages, so the above may not apply to you.

## REGISTER YOUR PURCHASE

-  [registeryourshark.com](http://registeryourshark.com)
-  Scan QR code using mobile device



Benefits of registering your product and creating an account:

- Get easier, faster product support and access to warranty information
- Access troubleshooting and product care instructions
- Be among the first to know about exclusive product promotions

**TIP:** You can find the model and serial numbers on the QR code label on the bottom of the back of the vacuum pod.

## RECORD THIS INFORMATION

Model Number: \_\_\_\_\_

Serial Number: \_\_\_\_\_

Date of Purchase: \_\_\_\_\_  
(Keep receipt)

Store of Purchase: \_\_\_\_\_

## TECHNICAL SPECIFICATIONS

Voltage: 120V~, 60Hz

Watts: 1400W

Amps: 11.8A



**PLEASE READ CAREFULLY AND KEEP FOR FUTURE REFERENCE.**

This Owner's Guide is designed to help you get a complete understanding of your new Shark® Vertex™ DuoClean® POWERFINS Powered Lift-Away® with Self-Cleaning Brushroll Upright Vacuum.

SharkNinja Operating LLC  
US: Needham, MA 02494  
CAN: Ville St-Laurent, QC H4S 1A7  
1-800-798-7398  
sharkclean.com

Illustrations may differ from actual product. We are constantly striving to improve our products; therefore the specifications contained herein are subject to change without notice.

For SharkNinja U.S. Patent information, visit [sharkninja.com/uspatents](http://sharkninja.com/uspatents)

---

© 2020 SharkNinja Operating LLC. DUOCLEAN, LIFT-AWAY, POWERED LIFT-AWAY, and SHARK are registered trademarks of SharkNinja Operating LLC. VERTEX is a trademark of SharkNinja Operating, LLC.

AZ2000BBB\_Series\_IB\_E\_MP\_Mv2  
PRINTED IN CHINA



@sharkcleaning