

Shark

Rocket® Deluxe Pro

UV330

OWNER'S GUIDE

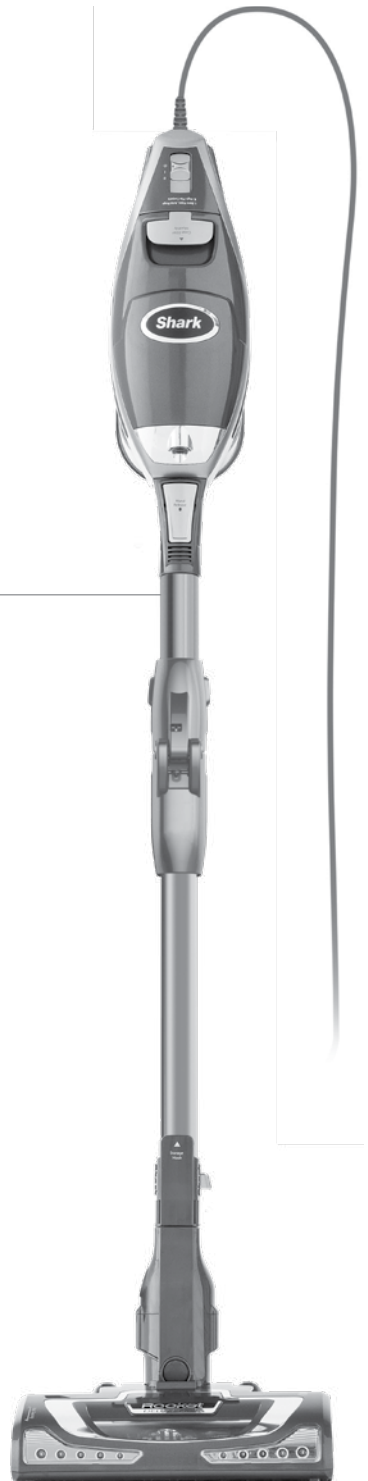

THANK YOU

for purchasing the Shark® Rocket® Deluxe Pro



TIP: You can find the model and serial numbers on the QR code label on the bottom of the dust cup.

REGISTER YOUR PURCHASE

- registryourshark.com
- 1-800-798-7398
- Scan QR code using mobile device

RECORD THIS INFORMATION

Model Number: _____
Serial Number: _____
Date of Purchase (Keep receipt): _____
Store of Purchase: _____

TECHNICAL SPECIFICATIONS

Voltage: 120V, 60Hz
Watts: 500W
Amps: 4.2A

PLEASE READ CAREFULLY AND KEEP FOR FUTURE REFERENCE.

This Owner's Guide is designed to help you get a complete understanding of your new Shark Rocket Deluxe Pro.

If you have any questions, please call the Customer Service line at 1-800-798-7398.

CONTENTS

Important Safety Instructions	3
Getting To Know Your Shark® Rocket® Deluxe Pro	5
Assembling Your Vacuum	7
Using the Motorized Floor Nozzle	8
Using Your Vacuum in Above-Floor Mode	9
Accessories	11
Storage	12
Maintaining Your Vacuum	13
Emptying the Dust Cup	13
Cleaning the Filters	14
Checking for Blockages	15
Troubleshooting Guide	17
Warranty	18

IMPORTANT SAFETY INSTRUCTIONS

HOUSEHOLD USE ONLY

To reduce the risk of electric shock, this vacuum cleaner has a polarized plug (one blade is wider than the other). As a safety feature, this plug will fit into a polarized outlet only one way. If the plug does not fit fully into the outlet, reverse the plug. If it still does not fit, contact a qualified electrician. DO NOT force into outlet or try to modify to fit.

⚠ WARNING

TO REDUCE THE RISK OF FIRE, ELECTRIC SHOCK OR INJURY:

GENERAL WARNINGS

1. Your vacuum cleaner may consist of a motorized nozzle, wand, hose, and/or vacuum pod. This device contains electrical connections, electrical wiring, and moving parts that potentially present risk to the user.
2. Use only identical replacement parts.
3. Carefully observe and follow the instructions provided below to avoid improper use of the appliance. **DO NOT** use the vacuum for any purpose other than those described in this manual.
4. Before use, carefully inspect all parts for any damage. **DO NOT** use if any parts are damaged.
5. The use of an extension cord is **NOT** recommended.
6. This vacuum cleaner contains no serviceable parts.

USE WARNINGS

7. **DO NOT** allow the appliance to be used by children. Close supervision is necessary when used near children. This is not a toy.
8. Always turn off the vacuum cleaner before connecting or disconnecting any motorized nozzles or other accessories.
9. **DO NOT** handle plug or vacuum cleaner with wet hands.
10. **DO NOT** use without filters in place.

11. Only use Shark® branded filters and accessories. Failure to do so will also void the warranty.
12. **DO NOT** damage the power cord:
 - a) **DO NOT** pull or carry vacuum cleaner by the cord or use the cord as a handle.
 - b) **DO NOT** unplug by pulling on cord. Grasp the plug, not the cord.
 - c) **DO NOT** run the vacuum cleaner over the power cord, close a door on the cord, pull the cord around sharp corners, or leave the cord near heated surfaces.
13. **DO NOT** put any objects into nozzle or accessory openings. **DO NOT** use with any opening blocked; keep free of dust, lint, hair, and anything that may reduce airflow.
14. **DO NOT** use if nozzle or accessory airflow is restricted. If the air paths or the motorized floor nozzle become blocked, turn the vacuum cleaner off and unplug from electrical outlet. Remove all obstructions before you plug in and turn on the unit again.
15. Keep nozzle and all vacuum openings away from hair, face, fingers, uncovered feet, or loose clothing.
16. **DO NOT** use if vacuum cleaner is not working as it should, or has been dropped, damaged, left outdoors, or dropped into water.

SAVE THESE INSTRUCTIONS

READ ALL INSTRUCTIONS BEFORE USE

17. Use extra care when cleaning on stairs.
18. **DO NOT** leave the vacuum cleaner unattended while plugged in.
19. When powered on, keep the vacuum cleaner moving over the carpet surface at all times to avoid damaging the carpet fibers.
20. **DO NOT** place vacuum cleaner on unstable surfaces such as chairs or tables.
21. Your Shark® vacuum may not be designed to stand up on its own. When taking a break from cleaning, you may need to lean it against furniture or a wall, or lay it flat on the floor. Using the vacuum for an application where the unit lacks stability may result in personal injury.
22. **DO NOT** use to pick up:
 - a) Liquids
 - b) Large objects
 - c) Hard or sharp objects (glass, nails, screws, or coins)
 - d) Large quantities of dust (drywall dust, fireplace ash, or embers). **DO NOT** use as an attachment to power tools for dust collection.
 - e) Smoking or burning objects (hot coals, cigarette butts, or matches)
 - f) Flammable or combustible materials (lighter fluid, gasoline, or kerosene)
 - g) Toxic materials (chlorine bleach, ammonia, or drain cleaner)
23. **DO NOT** use in the following areas:
 - a) Poorly lit areas
 - b) Wet or damp surfaces
 - c) Outdoor areas
 - d) Spaces that are enclosed and may contain explosive or toxic fumes or vapors (lighter fluid, gasoline, kerosene, paint, paint thinners, mothproofing substances, or flammable dust)
24. Turn off all controls before plugging in or unplugging the vacuum.
25. Unplug from electrical outlet when not in use and before any maintenance or cleaning.
26. Hand wash with water only. Washing with cleaning chemicals could damage the unit.
27. During cleaning or routine maintenance, **DO NOT** cut anything other than hair, fibers, or string wrapped around the brushroll.
28. Allow all filters to air-dry completely before replacing in the vacuum to prevent liquid from being drawn into electric parts.
29. Make sure the dust cup and all filters are in place after routine maintenance.
30. If provided, secure the power cord around the two cord hooks during storage.

GETTING TO KNOW YOUR SHARK® ROCKET® DELUXE PRO

WELCOME!

Congratulations on your purchase. Use this Owner's Guide to learn about your new vacuum's great features. From assembly to use to maintenance, you will find it all in here.

MAIN UNIT

- A** Power/Selector Switch
- B** Handheld Vacuum
- C** Dust Cup Release
- D** Handheld Vacuum Catch
- E** LED Light
- F** MultiFLEX® Storage Carry Handle
- G** MultiFLEX Wand Release
- H** MultiFLEX Lock Release Button
- I** MultiFLEX Wand
- J** Lower Wand Release Pedal
- K** Brushroll Indicator Light
- L** Motorized Floor Nozzle
- M** Headlights
- N** Cord Hooks (not shown)

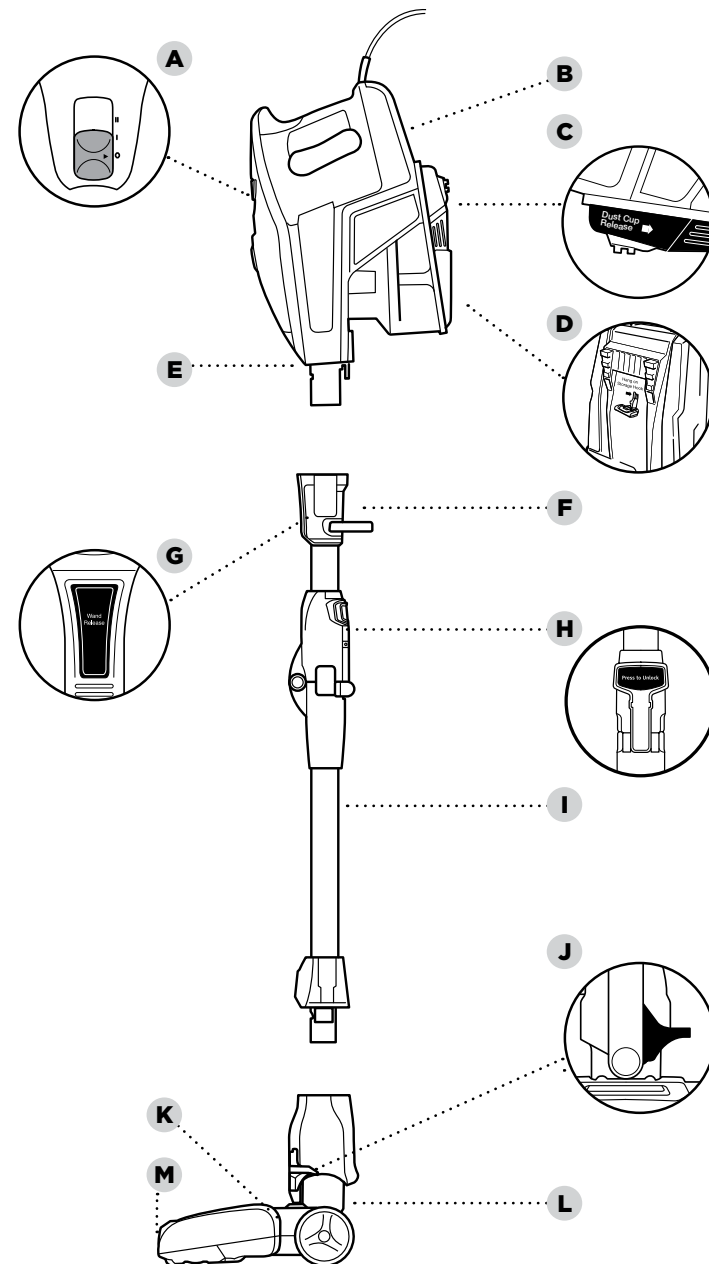

ASSEMBLING YOUR VACUUM

DID YOU KNOW?

The motorized floor nozzle and handheld vacuum have LED lights that illuminate the floor surface being cleaned. The lights turn on automatically in either speed setting.

NOTE: To place in MultiFLEX® Storage mode, press the MultiFLEX lock release button and gently fold the handheld vacuum forward toward the floor nozzle.

NOTE: Before vacuuming your small area rugs or carpet, refer to the manufacturer's recommended cleaning instructions.

WHAT DOES THE BRUSHROLL INDICATOR LIGHT MEAN?

Solid Green

The brushroll is on and working as it should.

Solid Red

There is a jam in the brushroll area. Turn your vacuum off and remove the blockage.

No Light

The brushroll is not spinning.

Flashing Red

The motorized floor nozzle is overheating. Turn your vacuum off and wait for it to cool down. See Troubleshooting section for more information.

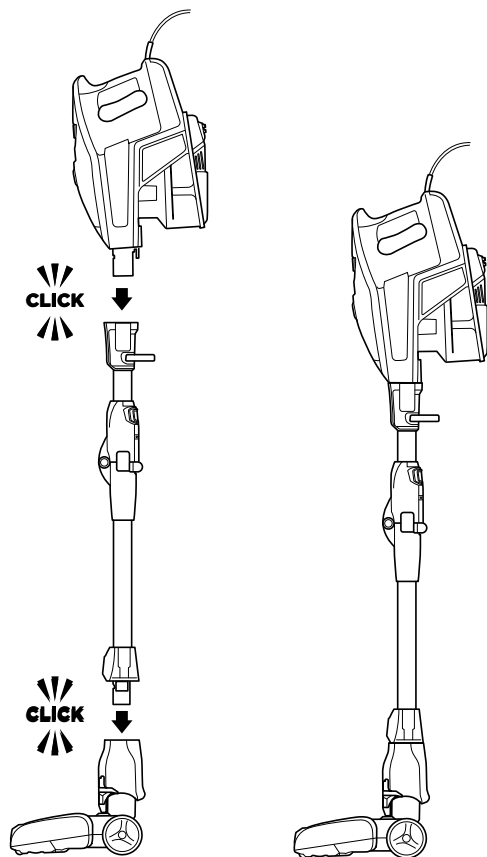

- 1 Insert the wand into the motorized floor nozzle connector, pressing it in until it clicks securely into place.
- 2 Insert the handheld vacuum into the top of the wand, pressing it in until it clicks securely into place.

USING THE MOTORIZED FLOOR NOZZLE

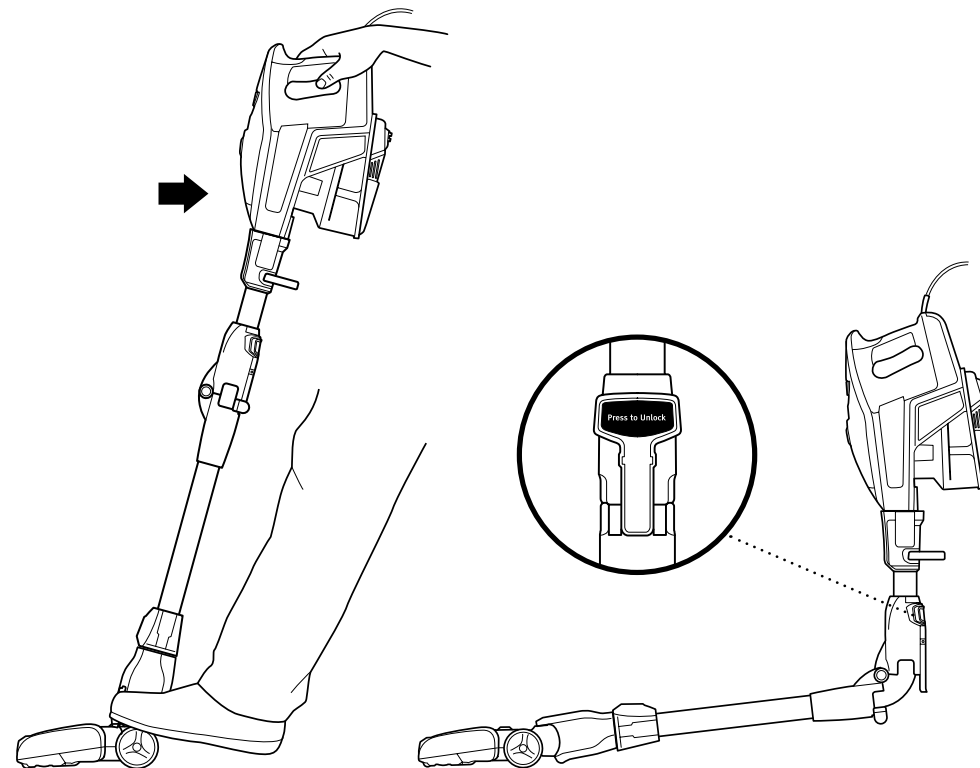

- 1 Slide the Power/Selector Switch to the appropriate setting:
Setting O: Turns off power.
Setting I: For cleaning bare floors and small area rugs.
Setting II: For cleaning carpets.

To start cleaning, recline wand to activate brushrolls.

NOTE: For deep carpet cleaning per ASTM F608 (embedded dirt in carpets) please use setting II, Carpets.

Using the MultiFLEX® Wand

To easily access hard-to-reach areas under furniture, press the MultiFLEX lock release button to position the wand to a lower angle.

USING YOUR VACUUM IN ABOVE-FLOOR MODE

NOTE: Both settings provide the same suction power.

TIP: You can attach the handheld vacuum directly to the motorized floor nozzle for convenient stair cleaning.

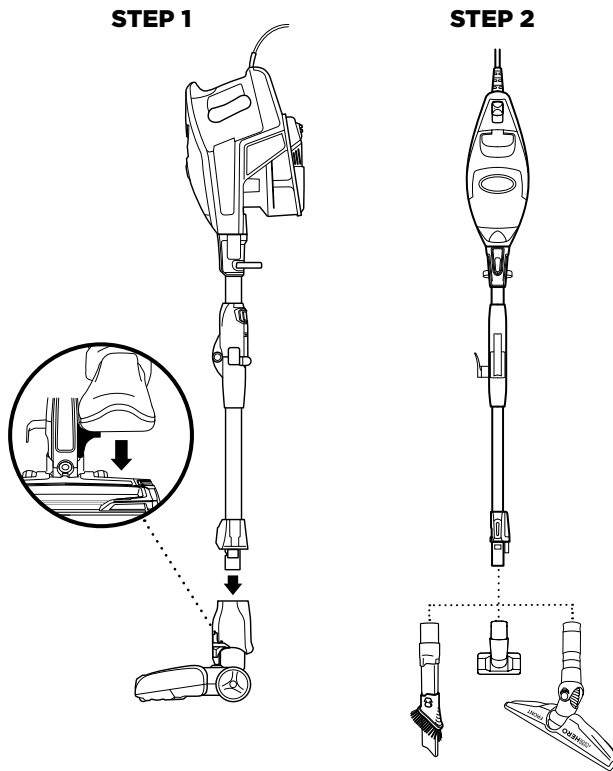

For Long-Reach Cleaning:

- 1** Stand the vacuum upright. Step on the foot pedal and pull the wand up to disconnect it from the motorized floor nozzle.
- 2** Attach desired cleaning accessory to the wand. Press MultiFLEX® Lock Release button to vacuum with wand at an angle.

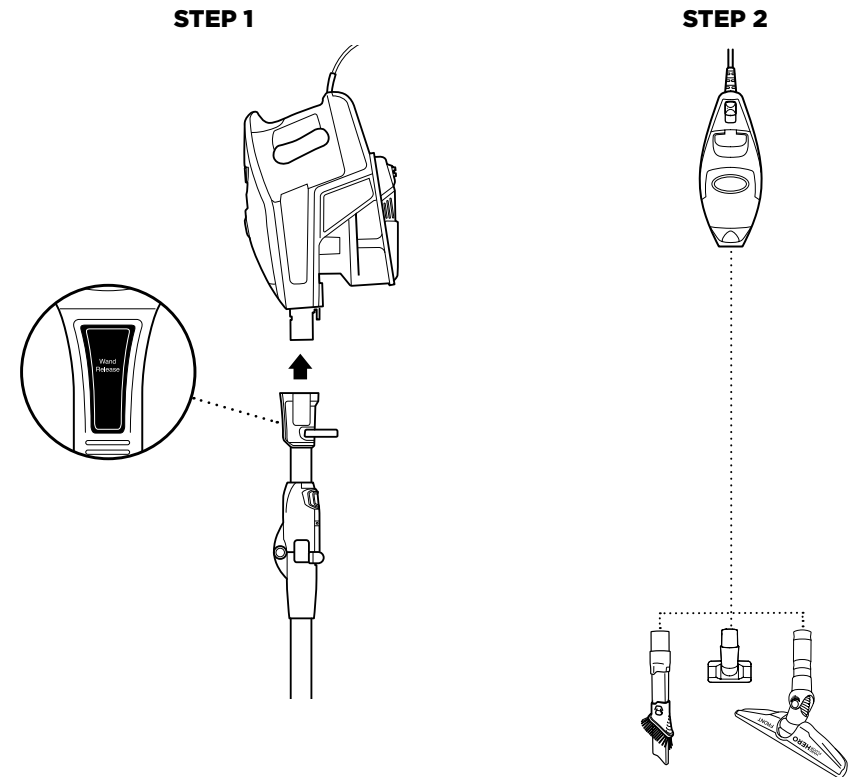

For Short-Reach Cleaning:

- 1** Press the Wand Release button on the top of the wand to detach the handheld vacuum.
- 2** Attach desired cleaning accessory or motorized floor nozzle to the handheld vacuum. The LED light on the handheld vacuum turns on automatically when the power is on.

ACCESSORIES

There are a variety of accessories that are compatible with this vacuum series.

The Quick Start Guide shows the select accessories that are included with your model.

To purchase additional accessories, visit sharkaccessories.com

A Duster Crevice Tool

Two cleaning tools in one. The crevice tool provides extended reach into small spaces, while the dusting brush cleans a multitude of surfaces.

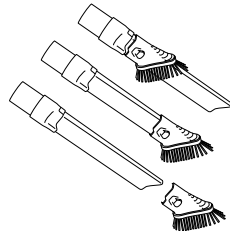

B Upholstery Tool

Perfect for grabbing pet hair and lint from furniture and other upholstered surfaces.

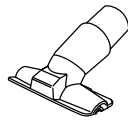

C Hard Floor Hero™ Attachment

Provides outstanding hard floor cleaning for not just surface litter, but also stuck-on dust and debris. It is small enough to get into hard-to-reach areas.

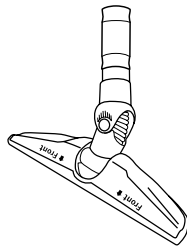

D Wall Mount

Install the mount to hang your vacuum on the wall for convenient storage. Includes screws, anchors, and instruction sheet with mounting template for easy installation.



E Onboard Storage Clip

Removable clip attaches to the vacuum wand. Can hold up to two accessories at a time while cleaning or for storage.

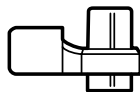

STORAGE

TIP: The carry handle located below the handheld vacuum can also be used to assist in taking the vacuum in and out of MultiFLEX® Storage mode.

OPTION 1

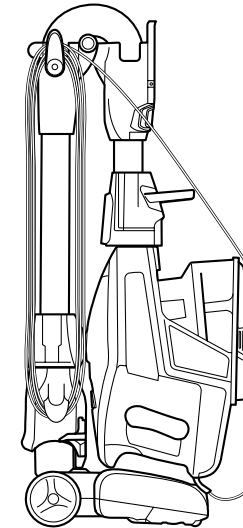

- 1 Press the MultiFLEX lock release button and fold the handheld vacuum forward toward the nozzle. Wrap the cord around the two cord hooks in a counterclockwise direction, starting with the top. Use the handle to carry the vacuum to its storage location.

To take the vacuum out of storage mode, press the MultiFLEX lock release button on the wand while lifting up the handheld vacuum until it straightens and locks into place.

Note: Ensure there is slack where the cord connects to the handheld vacuum.

MAINTAINING YOUR VACUUM

★ **IMPORTANT:** Clean the dust screen inside the dust cup as required.

NOTE: Empty dust cup when debris reaches the MAX fill line.

RECOMMENDED FILTER CLEANING SCHEDULE:

Pre-Motor Filter Kit

(Foam & Felt)
XPMFK320
Clean once a month.

Post-Motor Filter

1084FTV320
Clean once a year.

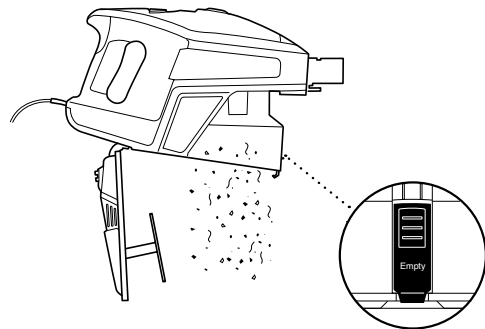
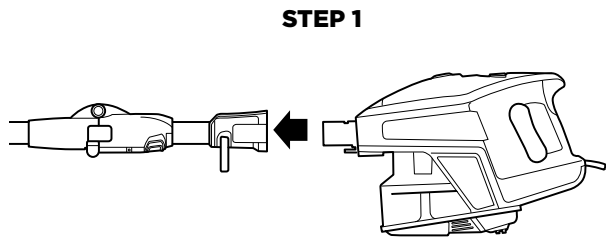

EMPTYING THE DUST CUP

- 1 Press the Wand Release button on the top of the wand to disconnect it from the handheld vacuum.

OR

Remove the dust cup from the handheld vacuum by squeezing the two Dust Cup Release buttons on both sides of the base at the same time, then pull out the dust cup.

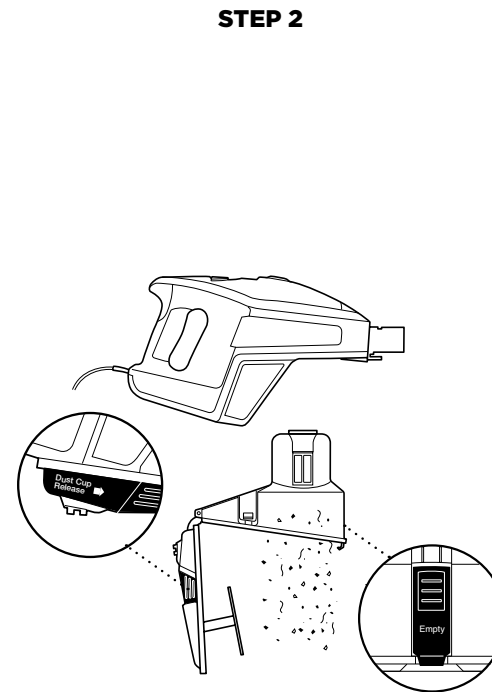

- 2 Hold dust cup over a trash bin and press the Empty button on the front of the dust cup. The bottom lid will open, allowing the debris to fall out.
- 3 Once dust cup is empty, close the bottom lid and insert dust cup back into handheld vacuum, pressing it in until it clicks into place.

CLEANING THE FILTERS

- 1 Access the Pre-Motor foam and felt filters by lifting the latch on the top of the handheld vacuum. Remove and rinse the filters with water. **DO NOT** use soap. Tap loose dirt off filters between washes as needed. Allow filters to air-dry completely, then reinstall them. Insert the felt filter first, then place the foam filter on top of it.
- 2 Access the Post-Motor filter under the handle. Remove and rinse the filter with water. **DO NOT** use soap.

MAINTAINING YOUR VACUUM - continued

TIP: Ensure the bottom of the floor nozzle is completely sealed and locked before using.

TIP: You do not need any tools to open the floor nozzle—just a coin.

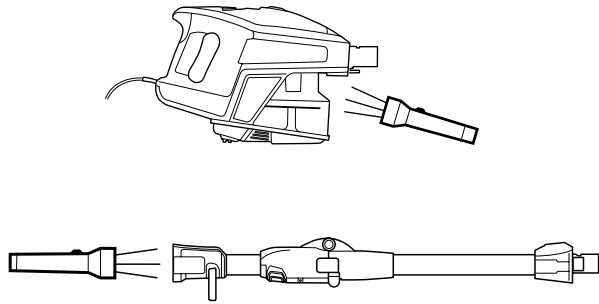

CHECKING FOR BLOCKAGES: HANDHELD VACUUM AND WAND

- 1 Remove the wand from the handheld vacuum and check all dust cup intake openings.
- 2 Remove the floor nozzle from the wand and check the wand for blockages.

STEP 1

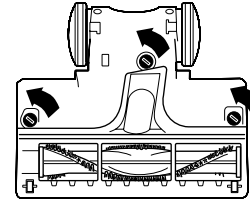

STEP 2

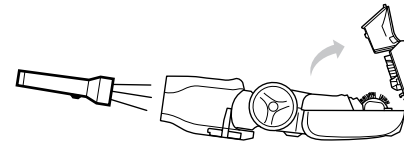

STEP 3

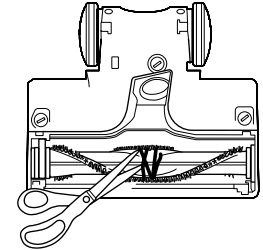

STEP 4

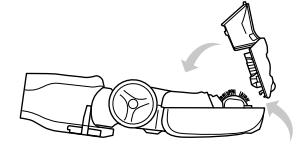

BOTTOM OF FLOOR NOZZLE

- 1 Use a coin to open the three locks on the bottom of the floor nozzle.
- 2 To access the brushroll, remove the cover from the bottom of the floor nozzle. Shine a flashlight from the bottom to check for possible blockages in the airway.
- 3 Remove any string, carpet fibers, or hair that may be wrapped around the brushroll. Loosen debris by running a pair of scissors along the groove in the brushroll.
- 4 To reinstall the cover, line it up, then rotate down until it clicks into place. Use the edge of a coin to close the three locks on the bottom of the nozzle.

Vacuum is not picking up debris. No suction or light suction. (Refer to Maintenance section for more information.)

- Check filters to see if they need cleaning. Follow instructions for rinsing and completely air-drying the filters before reinserting in the vacuum.
- Dust cup may be full; empty dust cup.
- Check floor nozzle for blockages; clear blockages if required.
- Remove any string, carpet fibers, or hair that may be wrapped around the brushroll.

Vacuum lifts area rugs.

- Suction is powerful. Take care when vacuuming area rugs or rugs with delicately sewn edges.
- Turn off the unit to disengage the brushroll and restart with the power-selector switch.

Brushroll does not spin.

- If Brushroll Indicator Light on the floor nozzle turns red, the brushroll has stopped spinning. Immediately turn off and unplug vacuum and remove blockage. Reconnect to power and turn vacuum back on.
- If Brushroll Indicator Light on the floor nozzle is green, the blockage has been successfully cleared. If the light is still red, please contact Customer Service at 1-800-798-7398.

Vacuum turns off on its own or indicator light flashes red.

This vacuum is equipped with a motor-protective thermostat so the vacuum will shut off if it overheats. Should this occur, perform the following steps to restart the motor-protective thermostat:

1. Turn vacuum off and unplug it.
2. Empty dust cup and clean filters (see Maintenance section).
3. Check for blockages in hose, accessories, and inlet openings.
4. Allow unit to cool for a minimum of 45 minutes.
5. Plug in vacuum and turn it on.

NOTE: If vacuum still does not work properly, contact Customer Service at 1-800-798-7398.

The Five (5) Year Limited Warranty applies to purchases made from authorized retailers of **SharkNinja Operating LLC**. Warranty coverage applies to the original owner and to the original product only and is not transferable.

SharkNinja warrants that the unit shall be free from defects in material and workmanship for a period of five (5) years from the date of purchase when it is used under normal household conditions and maintained according to the requirements outlined in the Owner's Guide, subject to the following conditions and exclusions:

What is covered by this warranty?

1. The original unit and/or non-wearable components deemed defective, in SharkNinja's sole discretion, will be repaired or replaced up to five (5) years from the original purchase date.
2. In the event a replacement unit is issued, the warranty coverage ends six (6) months following the receipt date of the replacement unit or the remainder of the existing warranty, whichever is later. SharkNinja reserves the right to replace the unit with one of equal or greater value.

What is not covered by this warranty?

1. Normal wear and tear of wearable parts (such as foam filters, HEPA filters, pads, etc.), which require regular maintenance and/or replacement to ensure the proper functioning of your unit, are not covered by this warranty. Replacement parts are available for purchase at sharkaccessories.com.
2. Any unit that has been tampered with or used for commercial purposes.
3. Damage caused by misuse (e.g., vacuuming up water or other liquids), abuse, negligent handling, failure to perform required maintenance (e.g., not cleaning the filters), or damage due to mishandling in transit.
4. Consequential and incidental damages.
5. Defects caused by repair persons not authorized by SharkNinja. These defects include damages caused in the process of shipping, altering, or repairing the SharkNinja product (or any of its parts) when the repair is performed by a repair person not authorized by SharkNinja.
6. Products purchased, used, or operated outside North America.

How to get service

If your appliance fails to operate properly while in use under normal household conditions within the warranty period, visit sharkclean.com/support for product care and maintenance self-help. Our Customer Service Specialists are also available at **1-800-798-7398** to assist with product support and warranty service options, including the possibility of upgrading to our VIP warranty service options for select product categories.

SharkNinja will cover the cost for the customer to send in the unit to us for repair or replacement. A fee of \$24.95 (subject to change) will be charged when SharkNinja ships the repaired or replacement unit.

How to initiate a warranty claim

You must call **1-800-798-7398** to initiate a warranty claim. You will need the receipt as proof of purchase.

A Customer Service Specialist will provide you with return and packing instruction information.

How state law applies

This warranty gives you specific legal rights, and you also may have other rights that vary from state to state. Some states do not permit the exclusion or limitation of incidental or consequential damages, so the above may not apply to you.



PLEASE READ CAREFULLY AND KEEP FOR FUTURE REFERENCE.

This Owner's Guide is designed to help you get a complete understanding of your new Shark® vacuum.

SharkNinja Operating LLC
US: Needham, MA 02494
CAN: Ville St-Laurent, QC H4S 1A7
1-800-798-7398
sharkclean.com

Illustrations may differ from actual product. We are constantly striving to improve our products; therefore the specifications contained herein are subject to change without notice.

For SharkNinja U.S. Patent information, visit sharkninja.com/uspatents

© 2019 SharkNinja Operating LLC. MULTIFLEX, ROCKET, and SHARK are registered trademarks of SharkNinja Operating LLC. HARD FLOOR HERO is a trademark of SharkNinja Operating LLC.

UV330_IB_REV_Mv11
PRINTED IN CHINA



@sharkcleaning