

# SMART FLOODLIGHT CAMERA

COCOON™

## Setup guide

Model: HE200074  
Version 1.1





Getting the most out of your Smart Floodlight Camera:



**Read the entire manual**

It will help you set up with ease



**Visit [www.cocoonproducts.com.au](http://www.cocoonproducts.com.au)**

We have additional support videos and guides



**Call After Sales Support - 1300 663 907**

Or email [help@cocoonproducts.com.au](mailto:help@cocoonproducts.com.au) - we're always happy to help

If you experience any issues with this product or its performance is not what you had expected, please contact our friendly customer service team

It is likely that we can resolve problems for you via phone or email

We can be reached on:

**Phone:** 1300 663 907 (Mon - Fri; 8:30am - 6:00pm AEST)

**Email:** [help@cocoonproducts.com.au](mailto:help@cocoonproducts.com.au)

**Web:** [www.cocoonproducts.com.au](http://www.cocoonproducts.com.au)



COCOON™

## SMART FLOODLIGHT CAMERA

# Warranty Details

---

**REGISTER YOUR PURCHASE AT [www.aldi.com.au/en/about-aldi/product-registration/](http://www.aldi.com.au/en/about-aldi/product-registration/)  
TO KEEP UP-TO-DATE WITH IMPORTANT PRODUCT INFORMATION**

---

The product is guaranteed to be free from defects in workmanship and parts for a period of 12 months from the date of purchase. Defects that occur within this warranty period, under normal use and care, will be repaired, replaced or refunded at our discretion. The benefits conferred by this warranty are in addition to all rights and remedies in respect of the product that the consumer has under the Competition and Consumer Act 2010 and similar state and territory laws.

Our goods come with guarantees that cannot be excluded under the Australian Consumer Law. You are entitled to a replacement or refund for a major failure and for compensation for any other reasonably foreseeable loss or damage. You are also entitled to have the goods repaired or replaced if the goods fail to be of acceptable quality and the failure does not amount to a major failure.

---

AFTER SALES SUPPORT

  1300 663 907

 [help@cocoonproducts.com.au](mailto:help@cocoonproducts.com.au)

MODEL: HE200074 PRODUCT CODE: 707036 10/2021



- **WARNING:** Risk of electrical shock
- Do not disassemble or repair.
- Installation and wiring must be performed by a licensed electrician
- Shut power off at the main switch board
- Verify that the supply voltage is correct.
- Always allow code standards when installing wired connections
- **CAUTION:** Risk of fire
- Do not install near combustible or flammable surfaces.
- Keep a minimum distance of 0.5m from adjacent objects.
- Do not connect this lighting fixture to a dimmer switch or timer
- Mount your Floodlight in a sheltered location.
- To avoid damage to unit - do not aim the sensor towards the sun.
- To avoid nuisance triggering, the sensor should be directed away from heat sources such as BBQ's, air conditioners, other outside lighting, flue vents and moving cars.
- Do not aim towards reflective surfaces such as smooth white walls or swimming pools etc.
- Avoid locating your Floodlight near fluorescent light fittings or ceiling fans on the same electrical circuit.
- The light must be wired to its own light switch. Do not interconnect with other lights on the same switch.
- LED light output is strong enough to injure human eyes. Do not look directly into the LEDs when operating.
- If the lighting fixture is damaged, it should be exclusively replaced by the manufacturer or the service agent or qualified person to avoid a hazard.
- If the external flexible cable or cord of this luminaire is damaged, it shall be exclusively replaced by the manufacturer or his service agent or a similar qualified person in order to avoid a hazard.
- The light source contained in this luminaire shall only be replaced by the manufacturer or his agent or a similar qualified person.
- Always refer to a licensed electrician if re-wiring the power cable.
- There are no user replaceable parts inside.
- The equipment is not suitable for use in locations where children are likely to be present.

This product has been tested to AS/NZS CISPR 32, AS/NZS 4268, AS/NZS 60598.1, AS/NZS 60598.2.1 and AS/NZS 62368.1.



READ AND UNDERSTAND THE MANUAL BEFORE USING THE PRODUCT



DIMMING NOT ALLOWED



CAUTION: RISK OF ELECTRIC SHOCK



Conforms to EMC and Safety standards



Do not stare at the operating light source

Warranty Note	3
Safety Instructions	5
Contents	6
Parts List	7
Product Overview	7
Technical Specifications	8
Installing the Cocoon Connect App	9
Before you start	9
Setting up the Cocoon Connect application for the first time	9
Create a Home	10
Setup	11
Installation	11
Sensor functions	12
Setting up Floodlight Camera in the Cocoon Connect app	12
Operation	14
Main controls	14
Settings menu	15
Additional Functionality	16
Adding other Cocoon Connect accounts to your Home	16
Troubleshooting	17
Firmware updates	17
FAQs	18
Maintenance, Storage & Disposal	19

## Parts List

1. 1 x Smart Floodlight Camera
2. 1 x Mounting bracket\*
3. 1 x Mounting accessories\*
4. 1 x Getting started guide\*
5. 1 x Setup guide\*
6. 1 x Warranty certificate\*

\* Not shown

## Floodlight Camera



## Product Overview

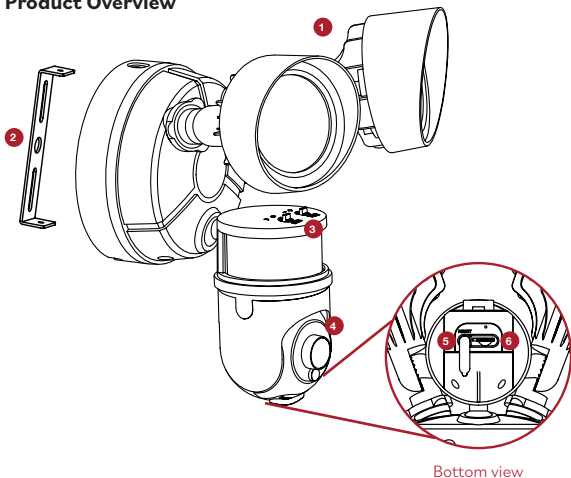

- |                     |                    |                      |
|---------------------|--------------------|----------------------|
| 1. Floodlights      | 3. Sensor controls | 5. Reset button      |
| 2. Mounting bracket | 4. Camera          | 6. MicroSD card slot |

### After Sales Support

☎ 1300 663 907

help@cocoonproducts.com.au  
www.cocoonproducts.com.au

Model number: HE200074  
10/2021

- 1080P Full HD video resolution with wide view angle
- 2200 lumens
- Input rating: 220-240VAC 50Hz
- Power 33W
- MicroSD Card Storage - Max 128G (MicroSD card not included)
- IP44

**NOTE:**

- *Your phone does not have to be connected to your local Wi-Fi to use this device, however mobile charges may apply*
- *The Cocoon Connect App is subject to change over time. The manual is written as per Cocoon Connect app version 1.1.5. Please see our website for any updates on the app*



**Before you start**

- Know your Wi-Fi network & password
- The Smart Floodlight Camera requires a Wi-Fi connection to communicate to the Cocoon Connect application
- Make sure your mobile device is running iOS 10.0 or higher or Android 4.4 or higher

**Setting up the Cocoon Connect application for the first time**

1. Download the Cocoon Connect application by scanning the QR code provided or downloading it from the iOS App Store or Google Play Store
2. Launch the application and select Register to register a Cocoon Connect account
3. Select Agree to Terms and Conditions and then you will be required to enter an email address and press Obtain verification code. A verification code will then be sent to the email address you entered
4. Enter the verification code into the password field
5. Set the password for your Cocoon Connect account



**OPTIONAL:** Click on eye icon to unhide the password

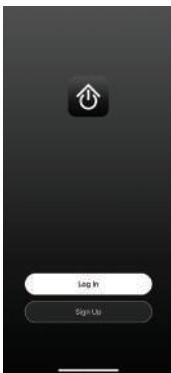

## Create a Home

The first time you set up the Cocoon Connect application, you will be prompted to create a Home.

Creating a home allows you to invite other Cocoon Connect account holders to control the same device. Creating a home is a good way of giving other household members control of Connected Home devices

1. Select Create home
2. Enter a name for the Home, for example use your surname, address or workplace etc.
3. Set the location for the Home. If location is turned on, the Cocoon Connect application can use your smartphone's GPS function to pinpoint your location.

**NOTE:** You do not have to enter a location or use this feature

4. Select (or un-select) rooms which will have Cocoon Connect devices (e.g. living room, bedroom, front door). Add new rooms if required
5. Select Done on the top right-hand side to create the Home. You will get the confirmation Home Created Successfully

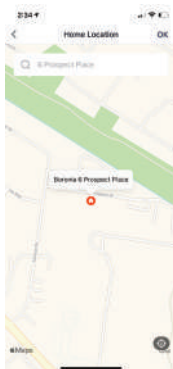
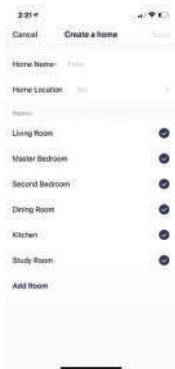

## Installation

- **MUST BE INSTALLED BY A LICENSED ELECTRICIAN.**
- **SHUT OFF POWER AT THE MAIN SWITCH BOARD BEFORE INSTALLING.**
- Turn off power to your Floodlight circuit at the main switch board to ensure no power is being sent.
- **BEFORE INSTALLATION, PLEASE CHECK THAT THE LOCATION OF THE SMART DEVICE IS WITHIN RANGE OF YOUR HOME WIFI & THE SIGNAL IS STRONG.**
- **IMPORTANT SAFETY ISSUES**
- Ensure the power is disconnected before installing.
- Modification of this product will void any warranty.
- When drilling into walls and ceilings, care must be taken to ensure you do not damage electrical wiring & other hidden utilities.

**NOTE:**

- Position of the Smart Floodlight Camera must be in strong WiFi range and no higher than 3 meters
- **Prior to installation, we recommend having an electrician powering on the Floodlight Camera so you can confirm it works properly in your chosen location. Balco Brands will not be held liable for a device not connecting reliably due to improper installation location**

1. Find a suitable position for your Smart Floodlight Camera

**NOTE:**

- An IP rating of IP44 is only suitable for external walls with supplementary protection such as overhanging eaves.
- The IP rating of this product is only valid when installed on a flat and non-porous surface. Additional sealing may be required for irregular surfaces.

2. Mark mounting holes using bracket (A) as a template.
3. Drill mounting holes and insert Rawl plugs (B) if necessary and secure bracket (A) to wall with supplied screw (C).
4. Attach the Smart Floodlight Camera to the bracket and secure with fixing screws.
5. The Smart Floodlight Camera needs to be connected to the mains power supply. To ensure this is done correctly, match earth, neutral & live cords separately as per diagram below.

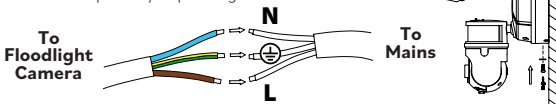
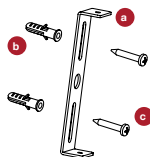
**NOTE:**

- **MUST BE INSTALLED BY A QUALIFIED ELECTRICAL CONTRACTOR**
  - The power cord must be kept away from any moisture & conductive parts
6. You can adjust the direction of the lamps by loosening the bolts. Point in desired direction then tighten the bolts to secure the lamp heads in place

## Sensor functions

### Time

Turn the control dial TIME to adjust the duration of the illumination of the light

The lighting duration can be adjusted from approx. 3 secs to 7 minutes (+/-10%). Turn the dial to the desired setting at any time via this switch on the Floodlight.

### Lux

This dial controls the time you want your floodlight to illuminate. Choose between ALL DAY or only at NIGHT. Turn the dial to the desired setting at any time via this switch on the Floodlight.



## Setting up Floodlight Camera in the Cocoon Connect app

1. Open the Cocoon Connect app on your phone which is connected to your Wi-Fi network and log into your account
2. Select the  Home tab on the bottom left hand side
3. Select the + icon on the top right-hand side or select Add Device to add a product
4. Select Add Manually, select AU in the menu on the left hand side, then select the Floodlight Camera icon on the right
5. Confirm the blue/purple LED on the Floodlight Camera is flashing by selecting Next Step. If not, reset the camera as per “FAQs” on page 18
6. Verify that your smartphone is connected to the Wi-Fi network you wish to connect the Floodlight Camera to.
  - a. With initial connection, it is recommended to have the Floodlight Camera near your Wi-Fi router to ensure a clear network connection
  - b. If there is more than one Wi-Fi network, you can change the Wi-Fi network your phone is connected to by selecting the Wi-Fi network name. You will be taken to your settings where you can change your network settings. Once changed, return to previous screen to enter your Wi-Fi password
  - c. Enter your local Wi-Fi password and select Confirm. You can click on the eye icon to see your password on your screen

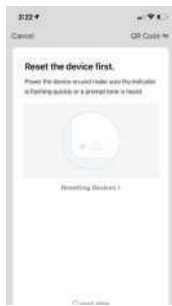

7. With the local Wi-Fi network confirmed, you will need to scan a unique QR Code that will appear on your phone

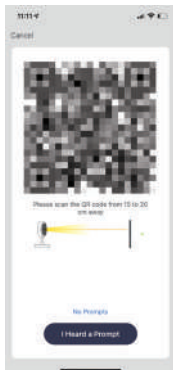

- a. Tap Continue and a QR Code will be displayed on the phone screen
- b. Place the phone approximately 15-20cm in front of the Floodlight Camera (LED blinking rapidly) with the QR code facing the camera
- c. The Floodlight Camera will read the unique QR code and an audible sound will be heard. In addition, the LED will turn blue and begin flashing
- d. Once you hear the sound, select Heard the Beep on the application
- e. If you do not hear a beep, select Heard nothing at all on the app and follow instructions on screen (see “Troubleshooting” on page 17)
8. Having selected Heard the Beep the application will begin registering the device with your account. This can take a few minutes
9. Once the Floodlight Camera is paired with the app, you will be asked to name it and to select a room
  - a. The name of the Floodlight Camera should be simple and descriptive
  - b. Select the room icon to select the Floodlight Camera’s location
  - c. Then select Complete. The app will then start retrieving the camera’s video stream
10. You can also view the video stream from the Product Control Screen
  - a. Your phone does not have to be connected to your local Wi-Fi to view the Floodlight Camera (however mobile data charges may apply if it’s not)

## Main controls

Once added to the Cocoon Connect app, you can tap on the Floodlight Camera from the home screen to access the video feed and controls. Each of the items on the screen allow the following functions:

- Date & Time Watermark:** Displays the device's date and time on video stream (must be turned on in settings)
- Settings:** Allows you to adjust further settings for the camera (see below)
- Signal:** Wi-Fi signal strength in percentage
- Speaker:** Select to hear audio from the camera
- HD / SD:** High Definition or Standard Definition selection
- Full Screen Icon:** Plays the video in full screen
- Screenshot:** Takes a screenshot of the current video stream onto your smartphone
- Speak:** Hold this button to allow two-way communication. Unmutes camera
- Record:** Activates the recording of real time video onto your Smartphone
- Playback:** Allows the playback of video stored on the SD Card (sold separately) in the Smart Floodlight Camera.
- Cloud Storage:** Set up cloud storage for records that cannot be destroyed or stolen
- NOTE: Additional fees apply**
- Direction:** Allows you to manually move the camera vertically and horizontally by placing and holding your finger on the selected arrow
- Alarm:** turn on/off motion detection notification settings, auto-track when motion is detected, schedule recording
- Lamp:** Allows you to manually turn on/off the floodlight
- Photo album:** Review images or videos recorded to your smartphone photo gallery

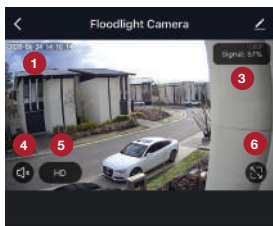

## Settings menu

- a. **Device Name:** Allows user to edit the name and Room location of the Smart Floodlight Camera
- b. **Share Device:** Allows user to share device to another user.  
It is recommended to share device via home management option (see “Adding other Cocoon Connect accounts to your Home” on page 16) so a Home member can control the device
- c. **Device Information:** Provides the device owner account name, device’s IP address, the unique device ID, device time zone & the Wi-Fi strength of the network
- d. **Use Echo:** Provides step by step instructions on adding the Smart Floodlight Camera to an Amazon Echo device (Sold separately)
- e. **Basic Function Settings:**
  - Status Indicator:
  - Flip Screen: Rotates the video stream 180°
  - Time Watermark:
  - IR Night Vision:
  - Talk Mode:
- f. **Motion Detection:** Adjust motion sensitivity between Off, Low, Medium or High
- g. **Value Added Service (VAS) Purchase:** Link to cloud storage for video stream of Smart Floodlight Camera
- h. **Storage Settings:**
  - Storage Capacity: Shows total, used and remaining capacity of SD Card (SD Card not included)
  - Local Recording: Switch on/off to use the SD card (not included)
  - Format: Completely erases the SD card
- i. **FAQ & Feedback:** The user can access our FAQs and also provide feedback via the app to resolve networking, application and device issues
- j. **Firmware information:** Provides current firmware version of the application, the last time it was updated and allows the user to check for firmware upgrades
- k. **Remove Device:** Allows you to remove the Smart Floodlight Camera from your account and home

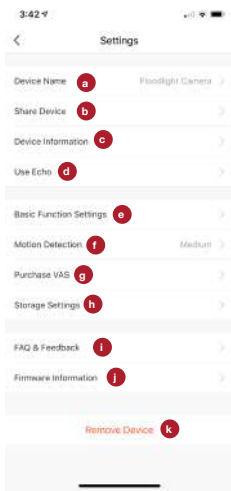

Now that you have set up this device you may want to connect it with other Cocoon Connect devices. For example, you may want a Smart Lamp to activate if a motion is detected. Instructions for applying such functions can be found on our website <https://cocoonproducts.com.au/>

Voice control, via third party support, is also another great way to control Cocoon Connect products. Voice control instruction can be found in our manual online. In addition, you will find a list of associated commands.

### **Adding other Cocoon Connect accounts to your Home**

Follow these steps to add allow other Cocoon Connect Accounts access to a Home:

- 1.** Select your current Home in the top left corner of the main page and select Home Management
- 2.** Select the Home you want to allow another account to access
- 3.** Select Add Member - the home member must set up an account prior to adding them
- 4.** Enter the name (or nickname) of that person
- 5.** Select a profile picture for that person (optional)
- 6.** Select country/region of the account
- 7.** Enter that account's mobile number or email address
- 8.** Select if you want to give that account administrator rights - allowing them to make changes to the settings of devices in that home (including removing the whole home). This will also allow them to create automations of these devices
- 9.** Select completed and Cocoon Connect will send an invitation for the account to join the home to access the connect devices



## My connection process does not work

If your connection process fails, then you may see the screen below

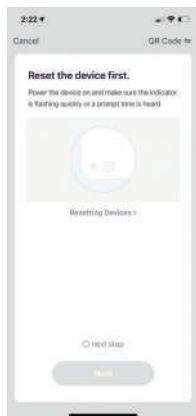

### Failed to add device

There are several potential problems, including but not limited to an incorrect Wi-Fi password, router firewall settings, network firewall settings, poor wireless communication and security settings on router. With the initial connection, it is recommended to have the device near your Wi-Fi router to ensure a clear network connection. For further troubleshooting, press the View Details tab

### Why is there no prompt from the camera?

If the device is not providing a prompt when the QR code is held up to the camera lens try the below:

1. Ensure that the lens is not blocked. If the camera has a protective film, remove it before you scan the QR code
2. Place the app QR code in front of the camera at a distance of 15cm to 20cm. Adjust the angle and distance until you hear a prompt
3. Reset your camera and try step 2 again

### Firmware updates

Visit <https://support.cocoonproducts.com.au> for the latest firmware updates for the Smart Floodlight Camera

Question	Solution
<b>Light does not switch ON when there is movement in the detection area</b>	<ul style="list-style-type: none"> <li>• Check all connections, fuses/ switches.</li> <li>• Ensure the Sensor is turned on via the app</li> <li>• Adjust LUX and SENS settings</li> </ul>
<b>Sensor will not operate during daylight</b>	<ul style="list-style-type: none"> <li>• First check that the power is turned 'ON'. Check connections, fuses, circuit breakers</li> <li>• Sensor isn't set into daylight operation mode</li> </ul>
<b>Sensor will not operate at night</b>	The level of ambient (street) light in the area may be too high. Adjust LUX level accordingly
<b>What if my Router is not 2.4GHz?</b>	Wi-Fi routers operate in two bands, 2.4GHz and 5GHz. Some routers operate on both bands simultaneously. The Smart Floodlight Camera can only operate on the 2.4GHz frequency
<b>How do I turn On/Off Push Notifications?</b>	Push notifications for the camera can be accessed in the settings function under motion detection. Push notifications for your whole account can be accessed via the settings in the 'Me' menu
<b>Where can I get additional Cocoon Connect products?</b>	Additional Cocoon Connect smart home products are available at your local ALDI store and at <a href="https://cocoonproducts.com.au">https://cocoonproducts.com.au</a>

For more information, setup guides and videos, please visit <https://cocoonproducts.com.au>

The Smart Floodlight Camera does not require scheduled maintenance or cleaning. Should cleaning be necessary, simply wipe the outside surface with a dry soft cloth. Be sure to unplug this device before cleaning. Always store your device in a clean dry environment and avoid storage in extreme heat or cold.

At the end of its working life, do not throw this product out with your household rubbish. Electrical and electronic products contain substances that can have a detrimental effect on the environment and human health if disposed of inappropriately. Observe any local regulations regarding the disposal of electrical consumer goods and dispose of it appropriately for recycling. Contact your local authorities for advice on recycling facilities in your area.

Observe and local regulations regarding the disposal of waste products. Contact your local authorities for advise on recycling facilities in your area.

Please keep the original packaging carton and materials in a safe place. It will help to prevent any damage if the product needs to be transported in the future. In the event it is to be disposed of, please recycle all packaging material where possible.

If you require another copy of this instruction manual, please contact [help@cocoonproducts.com.au](mailto:help@cocoonproducts.com.au) to obtain an electronic copy.



COCOON™

## SMART FLOODLIGHT CAMERA

# Repair and Refurbished Goods or Parts Notice

---

Unfortunately, from time to time, faulty products are manufactured which need to be returned to the Supplier for repair.

Please be aware that if your product is capable of retaining user-generated data (such as files stored on a computer hard drive, telephone numbers stored on a mobile telephone, songs stored on a portable media player, games saved on a games console or files stored on a USB memory stick) during the process of repair, some or all of your stored data may be lost.

**We recommend you save this data elsewhere prior to sending the product for repair.**

You should also be aware that rather than repairing goods, we may replace them with refurbished goods of the same type or use refurbished parts in the repair process.

**Please be assured though, refurbished parts or replacements are only used where they meet ALDI's stringent quality specifications.**

If at any time you feel your repair is being handled unsatisfactorily, you may escalate your complaint. Please telephone us on 1300 663 907 or write to us at:

Balco Brands Pty Ltd  
PO Box 537 Bayswater Business Centre, Victoria, Australia  
1300 663 907 - Hours: Mon-Fri 8:30am - 6:00pm AEST  
[help@cocoonproducts.com.au](mailto:help@cocoonproducts.com.au)

---

AFTER SALES SUPPORT

  1300 663 907

 [help@cocoonproducts.com.au](mailto:help@cocoonproducts.com.au)

MODEL: HE200074 PRODUCT CODE: 707036 10/2021





cocoon™

After Sales Support

Ph. 1300 663 907  
[help@cocoonproducts.com.au](mailto:help@cocoonproducts.com.au)