

©2010 ecobee
333 Adelaide Street West | 6th Floor
Toronto | Ontario | M5V 1R5 | Canada
toll free 1.877.932.6233
www.ecobee.com

IM-STAT-106-R5

SMART THERMOSTAT
Installation Manual

CONTENTS

Getting Started	2
Welcome	2
HVAC System Compatibility Information	4
Specifications	5
Installing the ecobee Smart Thermostat	7
Wiring Diagrams	9
Equipment Interface Status LED	18
Navigating the Smart Thermostat	19
Configuring the Installer Settings	20
Configuring the Reminder Alerts	27
Performing a Hardware Reset	27
Warranty	31

GETTING STARTED

Welcome

Thank you for supporting ecobee, the Smart Thermostat that provides your customers with freedom and flexibility in managing their home environment.

The ecobee Smart Thermostat has been designed in partnership with HVAC contractors to ensure the installation process is simple and efficient. This step-by-step Installation Manual will walk you through all aspects of the installation.

To ensure an on-going service relationship with your customers, please register all of your ecobee Smart Thermostats in your Contractor Portal.

The ecobee Team

Technical support

Our technical support team is available to answer your questions at **1.877-9-ecobee (1.877.932.6233)**, or via email at **support@ecobee.com**.

Before you begin

This product is intended to be installed by service professionals trained in all indoor residential environments.

This manual explains the procedures for installing the ecobee Smart Thermostat. Please read it carefully before beginning the installation.

For information on how to operate the ecobee Smart Thermostat, please see the ecobee User's Manual.

The ecobee Smart Thermostat consists of two parts (see images below):

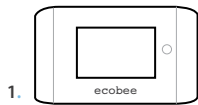

1.

1. **A Smart Thermostat** to be mounted on the homeowner's wall.

2. **An Equipment Interface Module** This should be mounted in the homeowner's utility room and connects to the heating, cooling and ventilation equipment.

Caution: Disconnect electric power to the system before installing this product. Failure to do so could result in electric shock and/or equipment damage.

All wiring must conform to your local electrical code.

Mercury Notice: This product does not contain mercury. If you are replacing a product that does contain mercury please contact your local waste-management authority for disposal instructions. Do not discard the old product in the regular trash.



2.

HVAC System compatibility information

ecobee is designed to operate low-voltage heating and cooling systems. It is not designed for use with line-voltage or millivolt heating and cooling systems. ecobee supports control of up to four heating stages and two cooling stages. It also supports control of humidifiers, dehumidifiers, heat-recovery ventilators and energy-recovery ventilators.

Equipment Description

Gas/Oil/Electric heating (up to three stages)	Yes
Heat pump with auxiliary heat (up to four stages)	Yes
Geothermal Heat Pump	Yes
Duel fuel systems	Yes
Standard electric cooling (up to two stages)	Yes
Boilers	Yes
Central humidifier	Yes
Central dehumidifier	Yes
Heat Recovery Ventilator (HRV)	Yes
Energy Recovery Ventilator (ERV)	Yes
Sensors with dry contact outputs	Yes

Approvals

This product was designed and built in accordance to RoHS directive 2002/95/EC and contains no hazardous substances as defined by this directive.

Optional Power supply meets EPA C.E.C Level IV and E.C CoC No Load power Consumption requirements. It is also safety approved to UL/cUL standards.

FCC Compliance Statement

This equipment has been tested and found to comply with the limits for Class B digital devices, pursuant to Part 15 of the FCC Rules. These limits are designed to provide reasonable protection against harmful interference in a residential installation. This equipment generates uses and can radiate radio frequency energy and, if not installed and used in accordance with the instruction manual, may cause harmful interference to radio communications. However, there is no guarantee that interference will not occur in a particular installation. If this equipment does cause harmful interference to radio or television reception, which can be determined by turning the equipment off and on, the user is encouraged to try to correct the interference by one or more of the following measures:

- Reorient or relocate the receiving antenna
- Increase the separation between the equipment and receiver
- Connect the equipment to an outlet on a different circuit from the receiver
- Consult the dealer or an experienced radio/TV contractor for help.

Warning: Changes or modifications not expressly approved by ecobee Inc. could void the user's authority to operate the equipment.

To satisfy FCC/IC RF exposure safety requirements, a separation distance of 20 cm or more should be maintained between this device and persons. To ensure compliance, operation at closer than this distance is not allowed.

FCC ID: WR9EBSTAT IC: 7981A-EBSTAT

Specifications

Temperature ranges

Heat: 45 – 79°F (7 – 26°C)
 Cool: 58 – 92°F (14 – 33°C)
 Display: 40 – 100°F (5 – 37°C)
 Sensitivity: +/- 1°F (0.5°C)
 Operating: 32 – 160°F (0 – 70°C)

Humidity Range

Humidify: 20 to 50% R.H
 Dehumidify: 30 to 60% R.H
 Display: 0 - 90% R.H
 Sensitivity: +/- 2% R.H.
 Operating: 5 – 95% R.H

Dimensions

Smart Thermostat: 5.5"W x 3.25"H x 1"D (139.5mm H x 82.5mm W x 25mm D)
 Equipment Interface: 4.6"W x 10"H x 1.3"D (118mm W x 254mm H x 32mm D)

Power

AC Transformer - 24 VAC - 3VA Minimum (*not included*),
 Optional Power Adaptor – 120V 50/60Hz to 12V DC 1A,
 Battery – CR2032 – 3V lithium coin cell (*included*)

Wiring Specifications

Refer to this table to determine maximum wire lengths allowed:

Smart Thermostat to Equipment Interface

18 AWG	20 AWG	22 AWG
1250ft/380m	790ft/240m	500ft/150m

Equipment Interface to heating/air equipment

18 AWG	20 AWG	22 AWG
128ft/39m	80ft/24m	50ft/15m

Terminal Description and Electrical Ratings

Terminal	Description	Voltage	Current max
Y	1st stage cooling	30V AC	3A
W (O/B)	1st stage heating (or changeover)	30V AC	3A
G	Fan	30V AC	3A
W2(AUX)	2nd stage heating (or 1st auxiliary heat)	30V AC	3A
R/H	Heat transformer return	30V AC	3A
R/C	Cool transformer return	30V AC	3A
ACC1	1st accessory relay	30V AC	3A
ACC1r	1st accessory relay return	30V AC	3A
ACC2	2nd accessory relay	30V AC	3A
ACC2r	2nd accessory relay return	30V AC	3A
ACC3	3rd accessory relay	30V AC	3A
ACC3r	3rd accessory relay return	30V AC	3A
IN1 +	Input 1 +	Dry contact only	Dry contact only
IN1-	Input 1 -	Dry contact only	Dry contact only
IN2+	Input 2 +	Dry contact only	Dry contact only
IN2-	Input 2-	Dry contact only	Dry contact only
+12v	12V DC power to thermostat	8-14V DC	600mA
GND	GND to thermostat	-	-
D+	Data + communication line	-	-
D-	Data - communication line	-	-

INSTALLING THE SMART THERMOSTAT

There are five steps to installing the ecobee Smart Thermostat

Step 1: Install the Equipment Interface.

Step 2: Wire the Equipment Interface.

Step 3: Install the Smart Thermostat.

Step 4: Connect the Smart Thermostat to the Equipment Interface.

Step 5: Power up both devices.

Installing the Equipment Interface

To install the Equipment Interface:

1. In the homeowner's utility room or basement, select a suitable location either on a wall or on the cold air return plenum. Make sure the surface is relatively flat and, if you are using a power adaptor, make sure there is an electrical outlet within five feet of where you plan to mount the device.

Note: Do not mount the device on the supply plenum or anywhere inside the heating or air conditioning equipment.

2. Remove the front cover of the Equipment Interface. If necessary, insert a flat-head screwdriver into one of the slots as shown below, and gently twist the screwdriver.

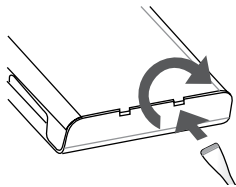

Insert a screwdriver into one of the two slots and twist gently

3. Place the back of the enclosure on the intended mounting surface and use it as a template to mark the location of the mounting holes, as shown below.

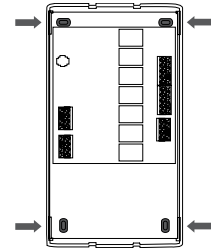

Mounting holes indicated with solid color

4. Move the back of the enclosure out of the way and make the holes where indicated in step 3. The mounting holes can accommodate a #6 pan-head screw.

5. Use drywall plugs or other screw anchors (not included) to ensure the Equipment Interface can be mounted securely.

6. Fasten the backplate to the wall using the appropriate screws (not included).

Wiring the Equipment Interface

To wire the Equipment Interface:

1. Disconnect the power to the heating and air conditioning equipment.

2. Disconnect the wires going to the existing thermostat.

3. Using the wiring diagrams on pages 9-11, connect the heating or air conditioning equipment to the Equipment Interface.

4. Do not apply power until you have installed and connected the Smart Thermostat. (see instructions on page 12-14)

5. Do not install the front cover on the Equipment Interface at this point.

Wiring diagrams

Below are the Equipment Interface Terminal Labels

Please take note that there is a factory installed jumper between R/H and R/C.

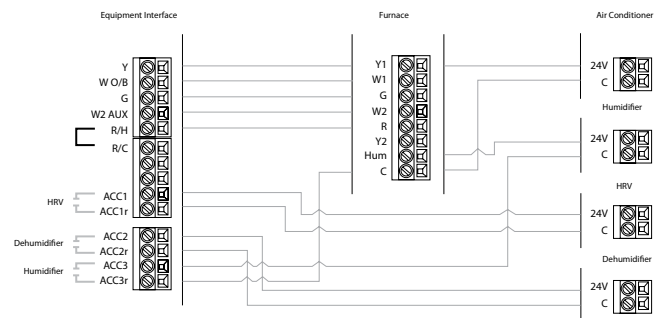
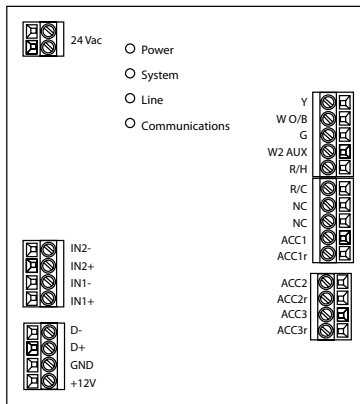

Dual Stage Heat, Single Stage Cool with Three Accessories

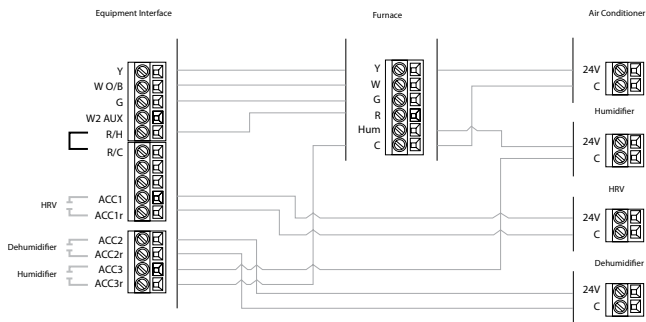

Single Stage Heat/Cool with Three Accessories

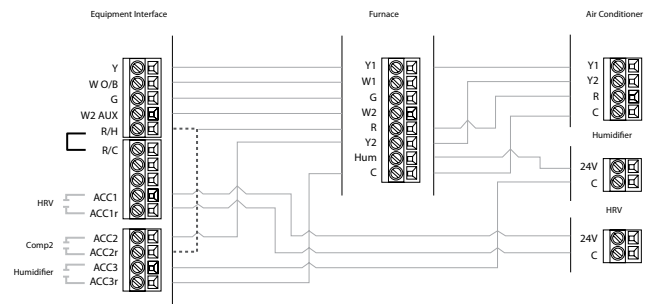

Dual Stage Heat/Cool with Two Accessories

••••• indicates a jumper. Non-powered accessories require a jumper from R/H / R/C to ACC1, ACC2, ACC3 for a 24V feed.

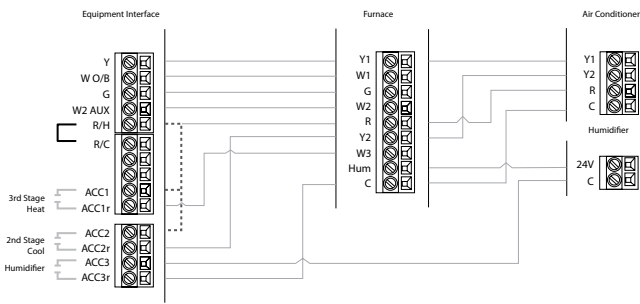

Three Stage Heat, Two Stage Cool with One Accessory

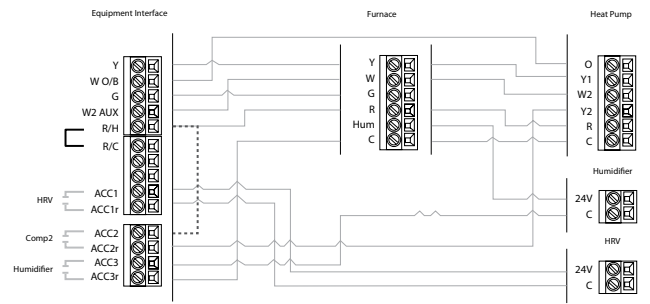

Dual Stage Heat/Cool, Single Stage Auxiliary Heat with Two Accessories

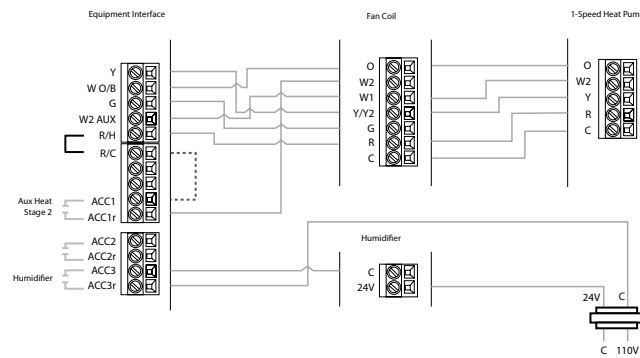

Single Stage Heat/Cool, Dual Stage Auxiliary Heat with Humidifier

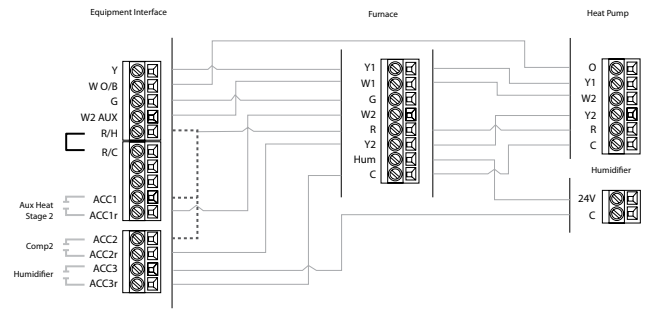

Dual Stage Heat/Cool, Dual Stage Auxiliary Heat with One Accessory

••••• indicates a jumper. Non-powered accessories require a jumper from RH / RC to ACC1, ACC2, ACC3 for a 24V feed.

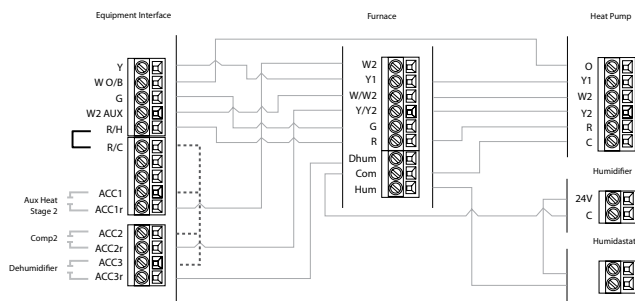

Dual Stage Furnace with Dehumidifier and Two Stage Heat Pump

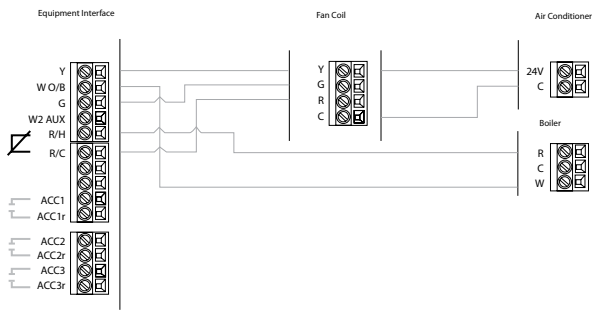

Single Stage Cooling with Boiler

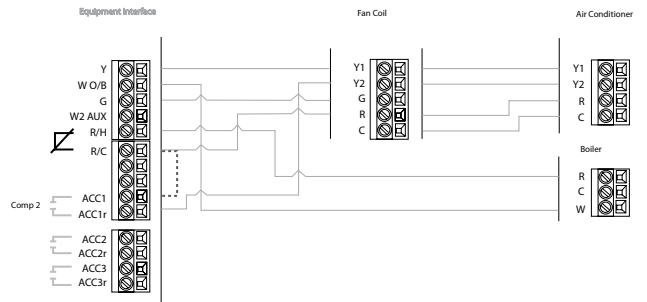

Dual Stage Cooling with Boiler

Remove factory installed jumper

..... indicates a jumper. Non-powered accessories require a jumper from R/H / R/C to ACC1, ACC2, ACC3 for a 24V feed.

Installing the Smart Thermostat

The ideal location for the Smart Thermostat is approximately five feet (1.5m) above floor level in the main living area.

Do not install the Smart Thermostat:

- Close to sources of heat such as incandescent lights or heating/cooling registers.
- In direct sunlight.
- On exterior, non-insulated or poorly insulated walls.
- In the kitchen or other areas of potentially high heat and/or humidity.
- In an area that could restrict air flow.

To install the Smart Thermostat:

1. Remove the front cover of the Smart Thermostat, insert a flat-head screwdriver into one of the slots as shown below and gently twist the screwdriver.

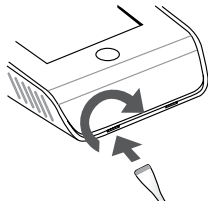

Insert screwdriver into one of the two slots and twist gently

2. Place the Smart Thermostat backplate on the wall. Make sure that any existing wires can be inserted through the opening for the wiring.
3. Using the backplate as a template, mark the location of the mounting holes on the wall as shown below.

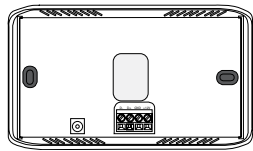

The solid color indicates mounting holes

4. Move the backplate out of the way and make holes where indicated in step 3. The mounting holes can accommodate a #6 pan-head screw.

5. Use drywall plugs or other screw anchors (not included) to ensure the Smart Thermostat can be mounted securely to the wall.

6. Fasten the backplate to the wall using the appropriate screws (not included).

Connecting the Smart Thermostat to the Equipment Interface

Only four wires are needed to connect the Smart Thermostat to the Equipment Interface. If you are replacing a thermostat, you can use the existing wiring.

Note: Ensure any unused wires do not have exposed bare copper conductors.

Follow these steps to connect the Smart Thermostat to the Equipment Interface:

1. Connect the wires between the Smart Thermostat and Equipment Interface as shown below.

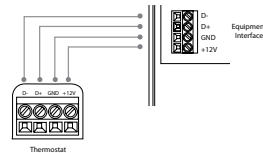

Wiring from Smart Thermostat to the Equipment Interface

2. Once wiring is complete, insert the coin cell battery (included) into the holder. Ensure the + side of the battery is facing out and the battery contacts remain in the upright position (not bent underneath the battery). The battery should snap in easily. (See page 15)

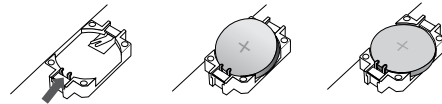

Slide the battery under the contacts and push down firmly

3. Attach the front cover of the Smart Thermostat to the backplate. Ensure the four pins on the circuit board mate with the terminal block on the backplate as shown below.

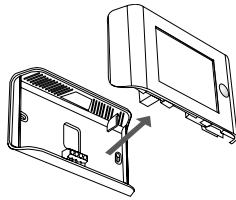

Replace the front cover ensuring the pins meet the terminals

Connecting power

Once you've completed the wiring of the Smart Thermostat and Equipment Interface, you can apply power to the Equipment Interface and restore power to the heating and air conditioning equipment.

There are two methods of powering the Smart Thermostat. You can power it directly from a 24VAC source capable of at least 3VA.

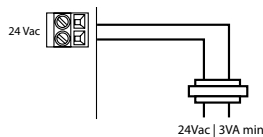

Hard-wired 24 VAC option

The second method requires the optional 120V to 12Vdc power adaptor. Plug the power supply into a standard electrical outlet and plug the barrel connector into the Equipment Interface.

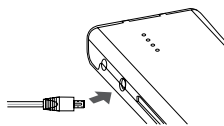

Plug the adaptor into the Equipment Interface

Equipment Interface Status LED

The Equipment Interface has four LEDs to display the status of the system.

If you've wired the system correctly, only the Power LED should be on.

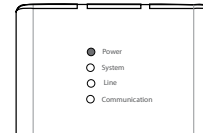

LED arrangement

The LEDs operate as follows:

Power This LED monitors the power supply of the Equipment Interface.

LED ON Power is connected to the Equipment Interface and is within the appropriate voltage range.

LED OFF Power is disconnected or has dropped below 9V.

System This LED monitors the operation of the Equipment Interface.

LED ON There is a fault with the Equipment Interface.

LED OFF The equipment interface is operational.

Line This LED monitors the power supplied to the Smart Thermostat from the Equipment Interface.

LED ON The voltage at the +12V and GND terminal has dropped below 7V.

LED OFF Adequate power is being supplied to the Smart Thermostat.

Communication This LED monitors the communication between the Smart Thermostat and the Equipment Interface (i.e., the D+ and D- terminals).

LED ON The Equipment Interface and Smart Thermostat are not communicating with each other.

LED OFF The two devices are communicating properly.

NAVIGATING THE SMART THERMOSTAT

Once the Smart Thermostat and Equipment Interface are powered up and working correctly, you can begin configuring the system.

The Smart Thermostat uses touch screen technology, so it's easy to navigate – just tap the icons, buttons and lists.

Note: To prevent damage to the touch screen, never use a sharp object such as a pen.



When the screen shows a list setting an arrow on the right, it indicates there are more than two options to choose from.



If there is no arrow, then the list item only has two options. Toggle between options by pressing the list item.

In the various screens, you have three navigation choices:



Press **Done** to save changes and move to the next screen.



Press **Cancel** to go back to the previous screen without saving changes.

At any time, press the **Home** button (found on the right-hand side of the touch screen). This cancels any action and takes you back to the home screen.

If you need to enter data in the form of text, you will be presented with a keyboard.

Pressing the Caps key will allow you to enter capital letters; pressing the 123@ key will change the letters to numbers or commonly used symbols.

CONFIGURING THE SMART THERMOSTAT

Configuring the Installer Settings

Installer Settings let you configure the settings related to the various devices (such as a furnace, air conditioner, humidifier, dehumidifier or ventilator) that are connected to the Equipment Interface.

To prevent accidental modifications to these settings you can enable a 4-digit installer code. This code is pre-programmed to 3262 and can be enabled in the Thresholds option menu.

Installation Wizard

The **Installation Wizard** takes you step-by-step through a series of choices regarding the HVAC equipment intended to be connected to the Equipment Interface. Simply answer the questions accordingly and press **Next** to advance to the next screen. Once completed you will be shown a diagram of the wiring connections that reflects the choices made during the wizard process. You can press **Back** to go back and make any changes. Once you are satisfied with the setup, press **Done**.

Equipment

The equipment setting will allow you to manually configure the various devices that are connected to the Equipment Interface.

Heat Pump

This section allows you to enable and configure up to a 2 stage heat pump. If a second stage is required you must configure an Accessory relay to control that stage

- **Geothermal/Ground Source Heat pump** If you select Yes, this tells the system a geothermal or ground source heat pump is being controlled. This helps the thermostat determine optimum performance and default settings. If you select NO, the system will optimize for an air-to-air heat pump.
- **O/B Energize on Cool** If you choose Yes, the reversing valve output (O/B terminal) will activate when there is a call for cooling. If you select No, the relay will energize when there is call for heat.

To Configure the installer settings:



From the Home screen, press More.



Press Settings and select Installation Settings

- **Min Cycle off Time** Enables you to configure the compressor off time between cycles. This is adjustable from 240 - 900 Seconds.
- **Min Outdoor Temp** Allows you to set the minimum outside air temperature at which the compressor will be disabled. This performs two functions: You can set it to prevent the compressor from going on when the outdoor temperature is too low, thus resulting in damage to the compressor. You can also set this value to determine when you want the auxiliary heat (if installed) to engage to help meet the set temperature. The temperature range is adjustable from 0°F (-17.8°C) - 65°F (18.3°C) or can be completely disabled. You will need an Internet connection for this feature to operate properly.
- **Allow Heat pump/Auxiliary Heat to run simultaneously** If you select Yes and there is a source of auxiliary heat, it will turn on in addition to the heat pump. The heat pump will be energized for the first 30 minutes. If, after 30 minutes, the set point has not been met, the auxiliary heat will be energized to assist the heat pump in meeting the load.

If you select no, the heat pump will be energized for up to 2 hours. If after 2 hours the set point has not been met, the thermostat will shutdown the heat pump and energize the auxiliary heat to meet the set point. This option should also be used for installation where the heat pump evaporator coil is downstream from the source of auxiliary heat.

Furnace (Auxiliary Heat)

Allows you to enable and configure up to a 3-stage conventional heat source. If you have selected Heat pump as your primary source, this feature will allow you to configure the auxiliary heat connected to the system.

- **Furnace Type** Allows you to configure the type of furnace connected. This allows the Smart thermostat to optimize its algorithms based on the type of fuel and typical characteristics of the chosen system. Choose the option that best represents the type of heating system installed.

- **Heat Stages** Allows you to configure up to 3 stages of heat. If you require a third stage, you must configure an accessory relay to control that stage.
- **Heat Fan Control** This option allows you to determine if the system fan is controlled by the system during heat cycles, or if the thermostat is required to control the fan. Normally the HVAC system controls the fan during heat cycles.

Air Conditioner

Allows you to enable and configure up to 2 stages of air conditioning. If you require a second stage, you must configure an accessory relay to control that stage.

Staging Method of Operation

The ecobee Smart Thermostat uses a unique method for staging for multi-stage heating or cooling. It uses a combination of intelligent algorithms and past performance to determine when to activate the stages. When there is a call for heat or cool, the system computes how long it would take for the system to reach the desired set point in stage 1, stage 2 or stage 3 accordingly. It will determine that highest stage at which a minimum of 10 minutes of run time is required. It will then automatically start the system at that stage (ie if it calculates that it will take 15 minutes at stage 2 but only 7 minutes at stage 3, the system will immediately turn on stage 2 to meet the set point). If the calculation indicates to start at stage 1, and it does takes more than 10 minutes to reach the set point, it will automatically engage stage 2. If stage 2 runs for more than 10 minute without reaching the set point it will activate stage 3. A minimum run time of 10 minutes is used to ensure that proper circulation throughout the system and that minimum cycle times are maintained. For heat pumps with auxiliary heat, the operation of the auxiliary heat will depend on the configuration of the "Allow heat pump and auxiliary heat to run simultaneously".

Accessory relays

Accessory relays are generic relays that can be configured to control the following;

- **Heat Stage 3** Select this option when the thermostat is required to control a 3-stage conventional heating system. Connect the third stage (or W3) contact to this accessory relay.

- **Auxiliary Heat Stage 2** Select this option when the thermostat is required to control a heat pump system with 2 stages of Auxiliary heat. Connect the second stage of the auxiliary heat to this relay.
- **Compressor/AC Stage 2** Select this option when the thermostat is required to control either a 2 stage heat pump or a 2 stage air conditioner. Connect the Y2 terminal of the system to this relay.
- **Humidifier** Select this option when the thermostat is required to control a humidifier. When this option is selected you will also be able to configure the following:
 - Humidify only while heating** If Yes is chosen, the system will activate this relay when the current humidity is below the humidity set point *and* there is a call for heat.
 - If No is chosen the system will activate this relay *and* the system fan when the current humidity is below the humidity set point. This is designed to support steam type humidifiers
 - Window Efficiency** To optimize the Frost control feature of this system, the system needs to know the efficiency ratio of the windows within the area being controlled by this system. Options are Low, Medium and High.
- **Dehumidifier** On a call for cool, if the current humidity is above the set point, this relay will be activated. When this option is selected you will also be able to configure if you wish to enable the fan during the dehumidification cycle. Choose yes if you are using the air conditioning system to dehumidify, choose No if you are using a standalone dehumidification system that independently controls the system fan.
- **Ventilator** Activated when the user engages Ventilator Max from the Details screen. The system fan will also turn on when Ventilator Max is engaged

Thresholds

This section will allow you to configure the various temperature or time thresholds associated with the heating and cooling equipment. You must configure the required equipment first before setting the thresholds, and only the application thresholds will be shown (i.e. if no Air Conditioner is configured, you will not see the options related to air conditioners).

Allow Auto Heat/Cool

Enable this option to allow the user to select Auto change-over as a system mode.

Heat/Cool Min Delta

The minimum difference between the heat mode set temperature and the cool mode set temperature when the system mode is in Auto change-over.

Compressor Settings

Min Cycle Off Time Allows you to configure the compressor off time between cycles. This ensures the compressor does not short cycle which could affect the operating life of the system. This is adjustable from 240 - 900 Seconds.

Min Outdoor Temp This section allows you to set the minimum outside air temperature at which the compressor will be disabled. This performs two functions: You can set it to prevent the compressor from going on when the outdoor temperature is too low, thus resulting in damage to the compressor. You can also set this value to determine when you want the auxiliary heat (if installed) to engage to help meet the set temperature. The temperature range is adjustable from 0°F (-17.8°C) - 65°F (18.3°C) or can be completely disabled. You will need an Internet connection for this feature to operate properly.

Aux Heat Settings

Max Outdoor Temperature Allows you to set the maximum outdoor temperature threshold. Above this level, the auxiliary heat will not be activated. Instead, the heat pump will maintain the set point.

Common Heat/Cool Settings

Heat Differential Temp The minimum difference between the current temperature and set temperature before the system calls for heat. A smaller difference means a more comfortable environment, whereas a larger difference is more economical.

Heat Dissipation Time The amount of time the fan will run after the heat set point has been reached and the call for heat has been turned off. Running the fan for a period of time allows for any heated air left in the ducts to circulate throughout the home.

Cool Differential Temp The minimum difference between the current temperature and the set temperature.

Cool Dissipation Time The amount of time the fan will run after the cool has been turned off. Running the fan for a period of time allows for any cooled air left in the ducts to circulate throughout the home.

Temp Correction

This will allow you to program an offset between what temperature the thermostat is measuring versus what is displayed. If you find that the temperature where the thermostat is located does not represent the room temperature, this offset allows you to compensate for that difference.

Installer Code

This option lets you enable or disable 3262 as the installer code.

Test Equipment

This section allows you to manually turn on and off the various equipment connected to the Equipment Interface, in order to test the wiring and connections.

Warning: Compressor protection and minimum run-time features are not enforced while in this mode.

In any of the screens within this section, the equipment will turn off when you select **Done**.

Sensors

This section allows you to configure the detector inputs on the Equipment Interface. This can be used to connect optional flood sensors, or other leak-detection devices.

Once an input has been triggered, it will generate an alert on the touch screen and send an e-mail if the thermostat has been registered with a web portal. Each input can be configured as normally open, where a short-circuit between the IN1+ and IN1 will activate the alert, or normally closed, where an open circuit will activate the alert.

To activate any input, select the input and program a name. To deactivate the input, simply delete the name.

View Wiring Diagram

This feature allows you to view the terminal connections of the equipment interface as determined by the configuration options selected during the installation process.

Contractor Info

This section allows you to enter your contact information. It will be displayed to the homeowner in the About menu, when any alert is shown on the touch screen and in his personal web portal. You can enter your:

- Company name
- Phone number
- Email address
- Website address.

If you are a registered ecobee contractor, you will have access to your Contractor portal. In this portal, you can enter the serial number of each ecobee Smart Thermostat you install. Once your registered thermostats are connected to the Internet, your contact information, including your company logo, will be automatically loaded onto them.

Reset Installation Settings

Selecting this option will restore all the installation settings back to the factory default. Any user setting (not related to the equipment installed) will remain unchanged.

Reset All Setting

Selecting this option will reset the entire Smart Thermostat system back to the original factory default settings.

Performing a Hardware reset

In rare circumstances, static electricity or power surges may interrupt the operation of the Smart Thermostat or Equipment Interface, forcing a hardware reset.

Resetting the Smart Thermostat

You can reset the Smart Thermostat by pressing the hardware reset button, located through an opening in the top left corner of the thermostat, as shown below.

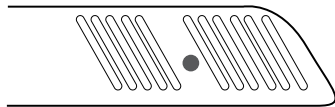

Reset button indicated in solid colour

Pressing the hardware reset button will not alter programming or configuration options.

Configuring reminder alerts

The Reminders list displays the reminders and alerts described below. Use the scroll bar at the right of the list to see all the settings.

HVAC Maintenance

The Maintenance reminder generates an alert telling the homeowner that regularly scheduled maintenance is required.

This alert, along with your contact information (if you programmed the information into the system), will be displayed on the touch screen. If the homeowner enrolls with www.ecobee.com, this reminder will be emailed to them and will also appear in their web portal.

Select this item to turn the reminder on or off, to show the date of the last service and to set a reminder interval between 1 and 12 months.

Furnace Filter

The Furnace Air Filter reminder generates an alert for cleaning or changing the furnace air filter.

Select this item to turn the reminder on or off, and to select the reminder interval (in hours or calendar months). This reminder also displays the date of the last filter change.

Humidity Filter

The Humidity Filter reminder generates an alert for cleaning or changing the humidity filter. Select this item to turn the reminder on or off, and to select the reminder interval (in hours or calendar months). This reminder also displays the date of the last filter change.

Dehumidifier Filter

Select this item to turn the reminder on or off, and to select the reminder interval (in hours or calendar months). This reminder also displays the date of the last filter change.

Ventilator Filter

Select this item to turn the reminder on or off to choose the reminder interval in run-time hours or calendar months. You can also check the date of the last filter change.

Note: If a humidifier, dehumidifier or ventilator is not configured in Accessory Relays, these options will not be displayed.

UV Lamp

Sets the reminder period for cleaning or replacing the UV lamp. Select this item to turn the reminder on or off and to set the reminder in calendar months. You can also check the date of the last lamp change.

Alerts

The Smart Thermostat can generate alerts when the temperature in the home reaches a pre-programmed level. This protects the home from damage due to freezing and/or excessive heat.

This alert, along with your contact information (if you programmed the information into the system) will be displayed on the touch screen. If the homeowner enrolls with www.ecobee.com, this reminder will be e-mailed to them and will also appear in their personal web portal.

To configure reminder alerts:



From the Home Screen, press More.



Press Settings and select Reminders and Alerts from the list.

Low Temperature Alert Select this to set the temperature at which the Smart Thermostat will generate a Low Temperature Alert. The range can be:

Off – no alert will be generated

Set temperature range of 35 – 68°F (1.5 – 20°C).

High Temperature Alert Select this to set the temperature at which the Smart Thermostat will generate a High Temperature Alert. The range can be:

Off – no alert will be generated

Set temperature range of 76 – 104°F (24.5 – 40°C).

Low Humidity Alert Select this item to set the humidity level at which the Smart Thermostat will generate a Low Humidity alert. The range can be adjusted to:

Off – no alert will be generated

Set humidity range of 5 – 95% R.H. in 5% increments

High Humidity Alert Select this item to set the humidity level at which the Smart Thermostat will generate a High Humidity alert. The range can be adjusted to:

Off – no alert will be generated

Set humidity range of 5-95% R.H. in 5% increments

Auxiliary Heat Run-time Alert (optional)

In a heat pump with auxiliary heat configuration, you can program the Smart Thermostat to generate an alert if the auxiliary heat runs for more than this programmed amount of time during a 24-hour period.

Auxiliary Outdoor Temperature Alert (optional)

In a heat pump with auxiliary heat configuration, you can program the Smart Thermostat to generate an alert if the auxiliary heat is called for when the outdoor temperature exceeds this programmed set point (this feature requires an internet connection to function properly)

List of Alerts

Below is a complete list of alerts. Depending on your configuration, some of these may not apply to your system.

Low Battery	The battery in your Thermostat will need to be changed soon.
Furnace Air Filter	Your furnace filter needs to be cleaned/changed.
Ventilator Filter	Your ventilator filter needs to be cleaned/changed.
UV Lamp	Your UV lamp needs to be changed.
Humidifier Filter	Your humidifier pad needs to be cleaned/changed.
Comms fault	There is no communication between the Thermostat and the Equipment Interface module.
Low Temp. Alert	The temperature in the home is too low.
High Temp Alert	The temperature in the home is too high.
Low Humidity Alert	The humidity in the home is too low.
High Humidity Alert	The Humidity in the home is too high.
Heat Not Responding	The system has failed to heat the home.
Cool Not Responding	The system has failed to cool the home.
Input 1	Used if this input is programmed to generate an alert.
Input 2	Used if this input is programmed to generate an alert.
Maintenance Reminder	You are due for regular maintenance.
Auxiliary Heat Run Time	Your auxiliary heat source is running too often.
Auxiliary Outdoor Temperature	Your auxiliary heat source is running at higher than expected outdoor temperatures.

3-Year Limited Warranty

ecobee warrants that for a period of three (3) years from the date of purchase by the consumer ("Customer"), the ecobee Smart Thermostat (excluding battery) (the "Product") shall be free of defects in materials and workmanship under normal use and service. During the warranty period, ecobee shall, at its option, repair or replace any defective Products, at no charge for labour or materials. Any replacement and/or repaired device are warranted for the remainder of the original warranty or ninety (90) days, whichever is longer.

If the product is defective, call Customer Service at 1-877-9-ecobee. ecobee will make the determination whether a replacement product can be sent to you or whether the product should be returned to the following address: ecobee Customer Service, 333 Adelaide Street West, 6th Fl., Toronto, ON M5V 1R5, Canada. In the event of a failure of a Product, Customer may:

(a) if Customer did not purchase the Product directly from ecobee, contact the third party contractor from whom the Product was purchased to obtain an equivalent replacement product, provided the contractor determines that the returned Product is defective and Customer is otherwise eligible to receive a replacement product;

(b) contact ecobee directly for service assistance at 1-877-9-ecobee and ecobee will make the determination whether an advance equivalent replacement Product can be sent to Customer with return shipping supplies (in which case a hold shall be put on Customer's credit card for the value of the replacement Product until ecobee has received the defective Product). Product should be returned to the following address: ecobee Customer Service, 333 Adelaide Street West, 6th Fl., Toronto, ON M5V 1R5, Canada. If the returned Product is found by ecobee to be defective and Customer is otherwise eligible to receive a replacement product, no amount shall be charged to Customer's credit card; or

(c) ship the defective Product directly to ecobee, in which case Customer shall contact ecobee directly at 1-877-9-ecobee, so ecobee can make the required shipping arrangements. Upon receipt of the defective Product, ecobee will ship an equivalent replacement product to Customer, provided the returned Product is found by ecobee to be defective and Customer is otherwise eligible to receive a replacement product.

This warranty does not cover removal or reinstallation costs and shall not apply if the damages were found to be caused by something other than defects in materials or workmanship, including without limitation, if the Product:

- was operated/stored in abnormal use or maintenance conditions;
- is repaired, modified or altered, unless ecobee expressly
- authorizes such repair, modification or alteration in writing;
- was subject to abuse, neglect, electrical fault, improper handling, accident or acts of nature;
- was not installed by a licensed Heating Ventilating and Air Conditioning (HVAC) contractor; or
- was installed improperly.

ecobee's sole responsibility shall be to repair or replace the Product within the terms stated above. ECOBEE SHALL NOT BE LIABLE FOR ANY LOSS OR DAMAGE OF ANY KIND, INCLUDING ANY SPECIAL, INCIDENTAL OR CONSEQUENTIAL DAMAGES RESULTING, DIRECTLY OR INDIRECTLY, FROM ANY BREACH OF ANY WARRANTY, EXPRESS OR IMPLIED, OR ANY OTHER FAILURE OF THIS PRODUCT. Some US states and Canadian provinces do not allow the exclusion or limitation of incidental or consequential damages, so the above limitation or exclusion may not apply to you.

ecobee's responsibility for malfunctions and defects in materials and workmanship is limited to repair and replacement as set forth in this warranty statement. All express and implied warranties for the product, including but not limited to any implied warranties and conditions of merchantability and fitness for a particular purpose, are limited to the three-year duration of this limited warranty. No warranties, whether express or implied, will apply after the limited warranty period has expired. Some US states and Canadian provinces do not allow limitations on how long an implied warranty lasts, so this limitation may not apply.

ecobee neither assumes responsibility for nor authorizes any other person purporting to act on its behalf to modify or to change this warranty, nor to assume for it any other warranty or liability concerning this product.

This warranty gives you specific rights, and you may also have other rights which vary from jurisdiction to jurisdiction. If you have any questions regarding this warranty, please write ecobee Customer Service, 333 Adelaide Street West, 6th Floor, Toronto, Ontario M5V 1R5, Canada.