



# **Hisense**

Refrigerator Use & Care Guide

**Model:**  
**WMS017M6XBE**

For questions about features, operation/performance, parts or service, call:  
**1-877-465-3566**

# Table of Contents

Important Safety Instruction.....	1
Installation.....	3
Description of the Appliance.....	4
Temperature Control.....	6
Cleaning and Care.....	7
Energy Saving Tips.....	8
Trouble Shooting.....	8
Disposal of the appliance.....	10

# Important safety instructions

For your safety and correct usage, please read these instructions carefully before using your new appliance to avoid unnecessary mistakes and accidents. Please ensure that all people using this appliance are familiar with its operation and safety features. Keep these instructions in a safe place for future reference and be sure that they are kept with the appliance in the event that it is moved or sold, so that everyone using it through its life will be properly informed on its correct appliance usage and safety. The manufacturer is not responsible for damages caused by misuse. The appliance is for indoor and domestic use only.

## Electrical Information

- The appliance must be plugged into its own dedicated 115 Volt, 60 Hz., 15 Amp, AC only electrical outlet. The power cord of the appliance is equipped with a three-prong grounding plug for your protection against electrical shock hazards. It must be plugged directly into a properly grounded three prong receptacle. The receptacle must be installed in accordance with local codes and ordinances. Consult a

qualified electrician. Avoid connecting refrigerator to a Ground Fault Interruptor (GFI) circuit. Do not use an extension cord or adapter plug.

- If the SUPPLY CORD is damaged, it must be replaced by the manufacturer, its service agent or similarly qualified person in order to avoid a hazard.
- Never unplug the refrigerator by pulling on the power cord. Always grip the plug firmly, and pull straight out from the receptacle to prevent damaging the power cord.
- Unplug the refrigerator before cleaning and before replacing a light bulb to avoid electrical shock.
- Performance may be affected if the voltage varies by 10% or more. Such damage is not covered under your warranty.
- Do not plug the unit into an electrical outlet controlled by a wall switch or pull cord to prevent the refrigerator from being turned off accidentally.



### Fire Hazard

The appliance contains a small quantity of refrigerant (R600a) which is environmentally friendly but potentially flammable in the refrigerant circuit.

## Safety for Children and Others

### Who are Vulnerable

- This appliance is not intended for use by persons (including children) with reduced physical, sensory or mental capabilities, or lack of experience and knowledge, unless they have been given supervision or instruction concerning the use of the appliance by a person responsible for their safety. Children should be supervised to ensure that they do not play with the appliance.
- Keep all packaging away from children to avoid risk of suffocation.
- If you are discarding your old appliance, pull the plug out of the socket, cut the connection cable (as close to the appliance as you can). Cut off the main plug and discard. Break off any old locks or latches as a safeguard and remove the door to prevent children playing from suffering an electric shock or from closing themselves inside it.

### General safety and Daily use

- This appliance is intended to be used in household and similar applications such as:
  - staff kitchen areas in shops, offices and other working environments;
  - farm houses and by clients in hotels, motels and other residential type environments;
  - bed and breakfast environments;
  - catering and similar non-retail applications.
- Do not store flammable gases or liquids inside the appliance. There is a risk of an explosion.
- Do not operate any electrical appliances within the appliance (e.g. electric ice cream makers, mixers, etc.).
- When unplugging, always pull the

plug from the main outlet. Do not pull on the cord.

- Do not place hot items near the plastic components of this appliance.
- Do not place food products directly against the air outlet on the rear wall.
- Frozen food must not be refrozen once it has been thawed out.
- Store pre-packaged frozen food in accordance with the frozen food manufacturer's instructions.
- The appliance's manufacturer storage recommendations should be strictly adhered to. Refer to the relevant instructions for storage.
- Do not place carbonated or fizzy drinks in the freezer compartment as it creates pressure on the container, which may cause it to explode, resulting in damage to the appliance.
- Ice lollies (popsicles) can cause frost burns if consumed straight from the freezer compartment.
- Do not place food directly against the air outlet inside the refrigerator.
- Do not place the appliance in direct sunlight.
- Do not store explosive substances such as aerosol cans with a flammable propellant in this appliance.

### Proper Disposal of your

#### Refrigerator

#### Risk of Child Entrapment

Child entrapment and suffocation are not only problems of the past. Junked or abandoned refrigerators are still dangerous - even if they are sitting "for just a few days". If you are getting rid of your old refrigerator, please follow the instructions below to help prevent accidents.

#### Before you throw away your old refrigerator:

- Remove doors.
- Leave shelves in place so children may not easily climb inside.
- Have refrigerant removed by a qualified service technician.

# Installation

Before installing, follow these important first steps.

## Location

Position the appliance away from sources of heat such as stoves, radiators, direct sunlight etc. Maximum performance and safety are guaranteed by maintaining the correct indoor temperature for the class of unit concerned, as specified on the rating plate. This appliance performs well from 12.8 to 43.3 °C (55-110 °F). The appliance may not work properly if it is left for a longer period at a temperature above or below the indicated range.

## **IMPORTANT!**

There is a need of good ventilation around the fridge for easy dissipation of heat, high efficiency of refrigeration and low power consumption. For this purpose, sufficient clear space should be available around the fridge. It is advisable for there to be 75 mm (3 inch) separating the back of the fridge to the wall, at least 100 mm (4 inch) of space at its two sides, and a minimum of 100 mm (4 inch) from its top and a clear space up front to allow the doors to open 135°.

Appliances must not be exposed to rain. Sufficient air must be allowed to circulate in the lower rear section of appliance, as poor air circulation can affect performance.

**WARNING!!!** The foam pad above the compressor is only suitable for transport and must be removed before use.

## Cleaning

- Wash any removable parts of the refrigerator interior, and exterior with mild detergent and warm water. Wipe dry. Do not use harsh cleaners on these surfaces.
- Do not use razor blades or other sharp instruments, which can scratch the appliance surface when removing adhesive labels. Any glue left from the tape can be removed with a mixture of warm water and mild detergent, or touch the residue with the sticky side of tape already removed. Do not remove the serial plate.

**Caution:** flammable refrigerant used! When handling, moving and use of the refrigerator, make sure to avoid either damaging the refrigerant tubing, or increasing the risk of a leak.

- **WARNING:** Keep ventilation openings, in the appliance enclosure or in the built-in structure, clear of obstruction.
- **WARNING:** Do not use mechanical devices or other means to accelerate the defrosting process, other than those recommended by the manufacturer.
- **WARNING:** Do not damage the refrigerant circuit.
- **WARNING:** Do not use electrical appliances inside the food storage compartments of the appliance, unless they are of the type recommended by the manufacturer.

## Description of the Appliance

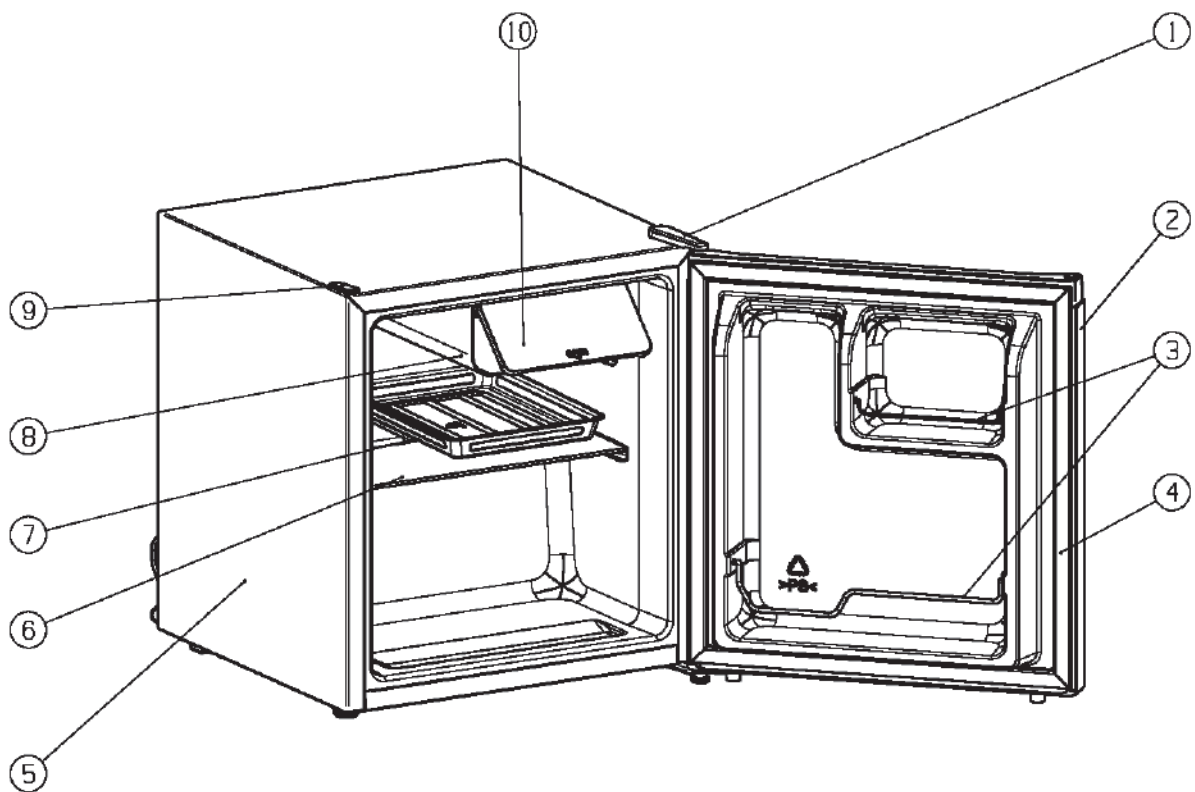

- |                     |                       |
|---------------------|-----------------------|
| ① upper hinge cover | ② refrigerator door   |
| ③ door rack         | ④ gasket part         |
| ⑤ cabinet           | ⑥ glass shelf         |
| ⑦ water drain tray  | ⑧ rollbond evaporator |
| ⑨ screw hole cover  | ⑩ chiller room cover  |

**NOTE: This figure is only a sketch of the refrigerator, the actual product may differ from it.**

### State of California Proposition 65 Warnings:

**WARNING:** This product contains one or more chemicals known to the State of California to cause cancer.

**WARNING:** This product contains one or more chemicals known to the State of California to cause birth defects or other reproductive harm.

### California (U.S.A.) Residents

▲ **WARNING:** Cancer and Reproductive Harm - [www.P65Warnings.ca.gov](http://www.P65Warnings.ca.gov)

## Reversing the Door

The side at which the door opens can be changed from the right side (as supplied) to the left side, if the installation site requires.

Tools you will need:

1. Wrench (5/16", 8mm)



2. Philips Screwdriver



3. Putty knife or thin-blade screwdriver

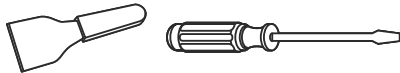

Before you start lay the refrigerator on it's back in order to gain access to the base, you should rest it on soft foam packaging or similar material to avoid damaging the cooling pipes at the rear of the refrigerator.

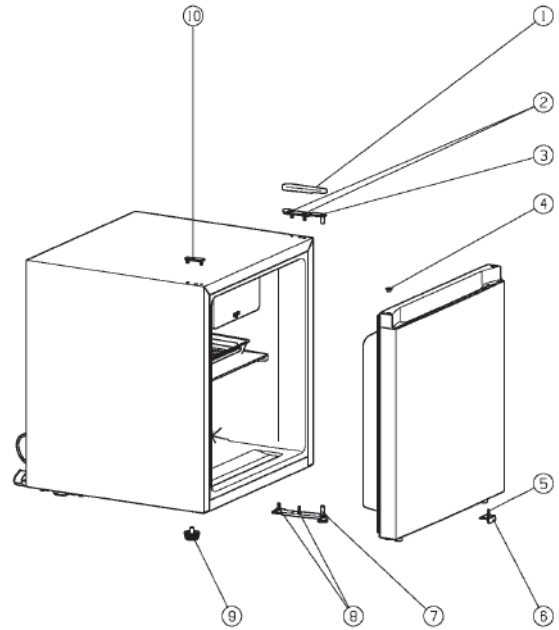

- |                     |                                     |                |
|---------------------|-------------------------------------|----------------|
| ① upper hinge cover | ② special flange self-tapping screw | ③ upper hinge  |
| ④ hinge hole cap    | ⑤ screw                             | ⑥ door stopper |
| ⑦ lower hinge       | ⑧ special flange self-tapping screw | ⑨ bottom feet  |
| ⑩ screw hole cover  |                                     |                |

- Open the refrigerator door and remove all fittings inside the door.
- Remove the upper hinge cover ①.
- Remove the two screws ② that connect the upper hinge ③ on the right side of the cabinet top.
- Carefully lift the door and place it on a padded surface to prevent scratching.
- Remove the screw hole cover ⑩ and hinge hole cap ④ and transfer it to the uncovered hole on the right side of the unit. Be sure to press the button firmly into the hole.
- Remove the screw ⑤ attached to the door stopper ⑥, then remove the door stopper, replace the door stopper to the other side of the door, and fix it with screw.
- Remove the two screws ⑧ that hold the lower hinge ⑦ on the right side of the cabinet.
- Remove the bottom feet ⑨ and transfer it to the right side of the cabinet.
- Set the door into its new place making sure the pin enters the bushing at the lower frame section (hole).
- Secure the upper hinge ③ previously removed in step 4 on the left side of the unit. Make sure the pin enters the bushing on the upper frame section (hole).
- Loosely secure the lower hinge ⑦ and do not tighten the bolts until the door is in the closed position and leveled.
- Replace the upper hinge cover ①.
- Turn the door upright again.
- Open the door and attach all fittings.

# Temperature Control

Insert the plug of the connection lead into an outlet with protective earth contact.

The temperature selector knob is located on the right side of the fridge.

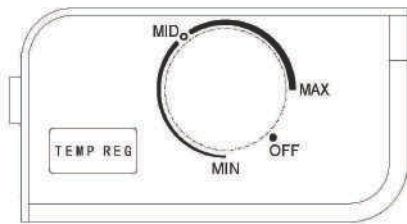

**Temperature Control**

## **Setting OFF means**

Turning the temperature control “OFF” position stops the cooling cycle, but does not shut off the power to the refrigerator.

Turn the knob clockwise to turn the refrigerating unit on. Coldest setting is all the way to “MAX” position. The unit operates automatically at the set position. If the unit is unplugged, power lost, or turned off, you must wait 3 to 5 minutes before restarting the unit. If you attempt to restart before this time delay, the refrigerator will not start.

## **Setting MIN means:**

Highest temperature, warmest setting.

## **Setting MAX means:**

Lowest temperature, coldest setting.

## **Setting MID means:**

Middle temperature, middle setting.

## **⚠ IMPORTANT !**

Normally we advise you select setting of “MID”, if you want the temperature warmer or colder please turn the knob to lower or higher setting accordingly. Though the unit is energy efficient, it is more efficient at lower position settings.

## **⚠ IMPORTANT !**

High ambient temperatures (e.g. on hot summer days) and a cold setting on the temperature regulator (position “MAX” ) can cause the compressor to run continuously or even non-stop! When the refrigerator is in use, the compressor needs being on and off normally to ensure its defrosting. Therefore, we should avoid setting the refrigerator’s notch too high(MAX). If you find the refrigerator frosts too much, please set the refrigerator’s notch lower.

## **Vacation Tips: If the appliance will not be used for several months :**

- Remove all food.
- Unplug the power cord.
- Clean and dry thoroughly.
- Leave the door open slightly to prevent odour and mould growth .



## Cleaning and Care

For hygienic reasons the appliance interior, including interior accessories, should be cleaned regularly. The fridge should be cleaned and maintained at least every two months.

### **Warning! Danger of electrical shock!**

- The appliance may not be connected to the outlet during cleaning! Before cleaning switch the appliance off and remove the plug from the mains, or switch off the circuit breaker or fuse.
- Remove the food from the appliance before cleaning. Store food in a cool place and keep well covered.
- Never clean the appliance with a steam cleaner. Moisture could accumulate in electrical components.
- Hot vapors can lead to the damage of plastic parts.
- The appliance must be dry before it is placed back into service.

### **IMPORTANT!**

- Ethereal oils and organic solvents can attack plastic parts, e.g. lemon juice or the juice from orange peel, butyric acid, and cleansers that contain acetic acid. Do not allow such substances to come into contact with appliance parts.
- Do not use any abrasive cleansers.
- Clean the appliance and the

interior accessories with a cloth and lukewarm water. Commercially available dish washing detergents may also be used.

- After cleaning, wipe with fresh water and a clean dish cloth.
- Accumulation of dust at the condenser increases energy consumption. For this reason carefully clean the condenser at the back of the appliance once a year with a soft brush or a vacuum cleaner.
- Check the water drain hole on the rear wall of the refrigerator compartment.
- Clear a blocked drain hole with the aid of something like a soft peg. Be careful not to create any damage to the cabinet by sharp objects.
- After everything is dry, place appliance back into service.

### **Defrosting Your Refrigerator**

- Defrosting process is automatic. Melted frost flows into drip tray and automatically evaporates.

- During the defrost cycle, water will accumulate in the drip tray. The drip tray may need to be emptied during the defrost cycle. Do not leave unattended.
- After defrosting is complete, empty

and wipe down the drip tray, as well as the interior of the refrigerator. You may now reset the refrigerator to the desired temperature and put the food back in.

## Energy Saving Tips

- Do not place warm foods into the appliance. Allow warm foods to cool first. Do not install the appliance near cookers, radiators or other sources of warmth. High ambient temperatures cause longer, more frequent operation of the compressor.
- In order to make the cooling system work efficiently, please make sure the side plates and back plate of the product are with some distance from the wall. It is strongly recommended that its back is 75 mm (3 inch) away from the wall, its sides are at least have a space of 100 mm (4 inch) separately and the height from over its top is no less than 100 mm (4 inch) .
- When the product works, please do not open the door too often or leave the door open any longer than necessary.
- Do not set temperature any colder than necessary.
- The direct cooling refrigerator (with a freezer) needs to be defrosted when necessary. This will improve the cold transfer and reduce energy consumption.
- The sketch map shows the right combination of the shelves which can lead to more energy efficiency.
- If users adjust the combination, it may result in more energy-consumption.
- Store food logically. Do not exceed the storage period specified.

## Trouble Shooting

### Correcting Malfunctions

A malfunction may be caused by only a minor fault that you can rectify yourself using the following instructions. Do not perform any other work on the appliance if the following information does not provide assistance in your specific case.

Please keep upright at least 2 hours before use to prevent damage of compressor.

### **IMPORTANT!**

Repairs to refrigerators/freezers should only be performed by qualified service technician. Improper repairs can give rise to significant hazards for the user. If your appliance needs repairing, please contact your specialist dealer or your local Service Center.

Problem	Possible	Cause Solution
Appliance does not work.	Appliance is not switched on.	Switch on the appliance.
	Main plug is not plugged in or is loose.	Insert main plug.
	Fuse has blown or is defective.	Check fuse, replace if necessary.
	Socket is defective.	Electrical malfunctions are to be corrected by an electrician.
Appliance cools too much.	Temperature is set too cold.	Turn the temperature regulator to a warmer setting temporarily.
The food is too warm.	Temperature is not properly adjusted.	Please look in the "temperature control" section.
	Door was open for an extended period.	Open the door only as long as necessary.
	A large quantity of warm food was placed in the appliance within the last 24 hours.	Turn the temperature regulation to a colder setting temporarily.
	The appliance is near a heat source.	Please look in the "installation" section.
Heavy build-up of frost, possibly also on the door seal.	Door seal is not air-tight (possibly after reversing the door).	Carefully warm the leaking sections of the door seal with a hair dryer (on a cool setting). At the same time shape the warmed door seal by hand such that it sits correctly.
Unusual noises	Appliance is not level.	Re-adjust the feet.
	The appliance is touching the wall or other objects.	Move the appliance slightly.
	A component, e.g. a pipe, on the rear of the appliance is touching another part of the appliance or the wall.	If necessary, carefully bend the component out of the way.
The compressor does not start immediately after changing the temperature setting.	This is normal, no error has occurred.	The compressor starts after a period of time.
Water on the floor or storage shelves.	Check that the drip tray is housed properly. Drip tray is full of water.	See the "cleaning and care" section.

## Disposal of the appliance

It is prohibited to dispose of this appliance as household waste.



Packaging materials:

Packaging materials with the recycle symbol are recyclable. Dispose of the packaging into a suitable waste collection container to recycle it.

Before disposal of the appliance:

1. Pull out the main plug from the main socket.
2. Cut off the power cord and discard with the main plug.

**Warning!** Refrigerators contain refrigerant and gases in the insulation. Refrigerant and gases must be disposed of professionally as they may cause eye injuries or ignition. Ensure that tubing of the refrigerant circuit is not damaged prior to proper disposal.

	<b>Correct Disposal of this product</b>
 	<p>This symbol on the product or in its packing indicates that this product may not be treated as household waste. Instead, it should be taken to the appropriate waste collection point for the recycling of electrical and electronic equipment. By ensuring this product is disposed of correctly, you will help prevent potential negative consequences for the environment and human health, which could otherwise be caused by the inappropriate waste handling of this product. For more detailed information about the recycling of this product, please contact your local council, your household waste disposal service, or the shop where you purchased the product.</p>

**Hisense**

life reimagined