

QUICK START GUIDE

Smart Safe

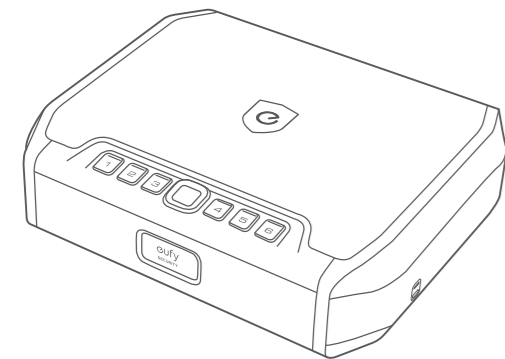

1 / OVERVIEW

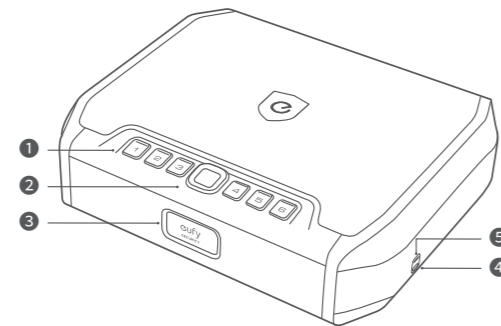

- 1 Keypad
- 2 Fingerprint Reader
- 3 Mechanical Lock
- 4 Charging Port
- 5 Charging Indicator

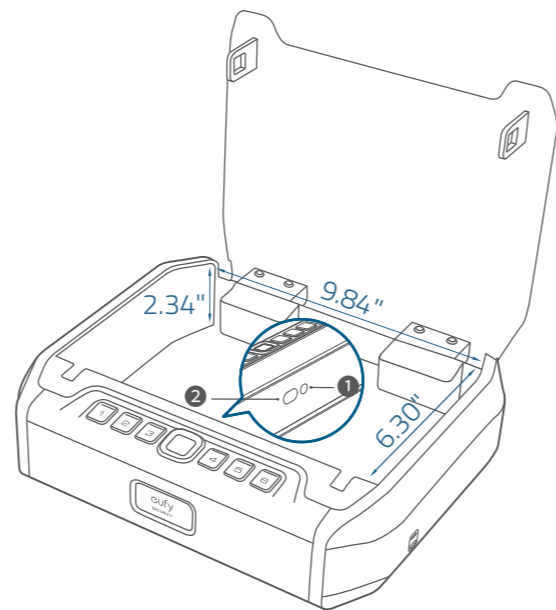

- 1 SYNC Button
- 2 LED Light

2 / SETUP

STEP 1. UNLOCK SMART SAFE

Two options are available for unlocking Smart Safe for the first time.

Option 1. Default Password



The default password "123456" will expire after setup. Use the eufy Security app to set a new password.

Option 2. Backup Key

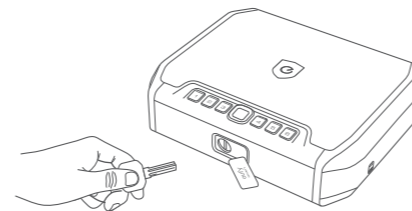

STEP 2. ADD TO THE EUFY SECURITY APP

1. Download and install the eufy Security app, then sign up for an account.



2. Follow on-screen instructions to complete the setup.

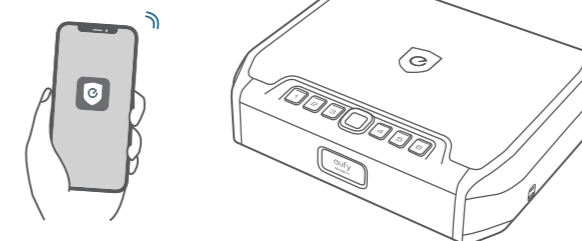

The model T7400 supports 2.4 GHz Wi-Fi only. Make sure the Wi-Fi signal is strong.

STEP 3. CHARGE SMART SAFE

Fully charge Smart Safe before first use. This may take 2 hours if you use a 5V/2A adapter.

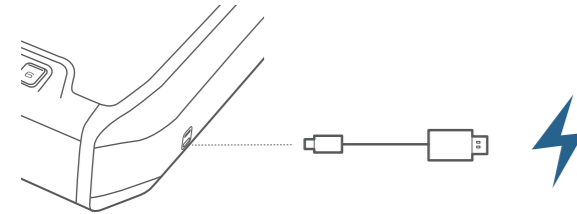

Charging Indicator	Description
Flashing blue	Charging
Blue	Fully charged

The battery life can last up to 6 months per charge.

5

STEP 4. MOUNT SMART SAFE (OPTIONAL)

You can mount Smart Safe through the screw holes on the bottom.

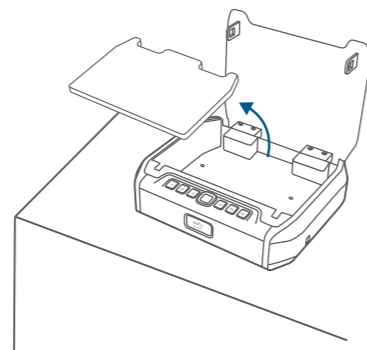

Option 1. Wooden Surface

What you need:

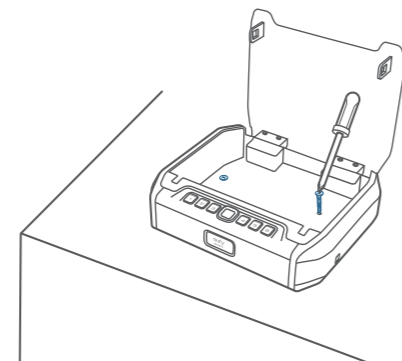

6

Option 2. Surfaces Made out of Hard Materials

What you need:

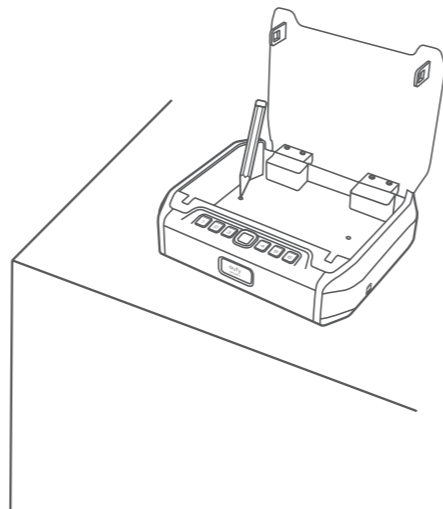

7

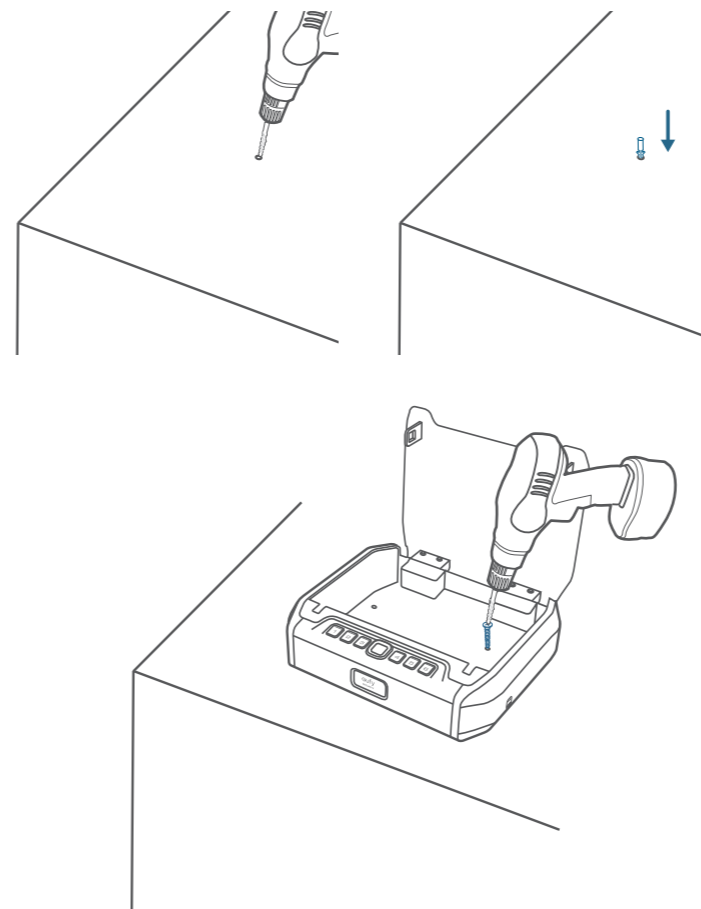

8

3 / NOTICE

FCC Statement

This device complies with Part 15 of the FCC Rules. Operation is subject to the following two conditions: (1) this device may not cause harmful interference, and (2) this device must accept any interference received, including interference that may cause undesired operation.

Warning: Changes or modifications not expressly approved by the party responsible for compliance could void the user's authority to operate the equipment.

Note: This equipment has been tested and found to comply with the limits for a Class B digital device, pursuant to Part 15 of the FCC Rules. These limits are designed to provide reasonable protection against harmful interference in a residential installation.

This equipment generates uses and can radiate radio frequency energy and, if not installed and used in accordance with the instructions, may cause harmful interference to radio communications. However, there is no guarantee that interference will not occur in a particular installation. If this equipment does cause harmful interference to radio or television reception, which can be determined by turning the equipment off and on, the user is encouraged to try to correct the interference by one or more of the following measures: (1) Reorient or relocate the receiving antenna. (2) Increase the separation between the equipment and receiver. (3) Connect the equipment into an outlet on a circuit different from that to which the receiver is connected. (4) Consult the dealer or an experienced radio/TV technician for help.

FCC Radio Frequency Exposure Statement

The device has been evaluated to meet general RF exposure requirements. The device can be used in fixed/mobile exposure condition. The min separation distance is 20cm.

Notice: Shielded cables

All connections to other computing devices must be made using shielded cables to maintain compliance with FCC regulations.

The following importer is the responsible party
 Company Name: POWER MOBILE LIFE, LLC
 Address: 10900 NE 8TH ST, STE 501, BELLEVUE, WA 98004
 Telephone: 1-800-988-7973

9

CUSTOMER SERVICE

Warranty

12-month limited warranty

Call Us

United States

+1 (800) 988 7973

Mon-Fri 9AM-5PM (PT)

United Kingdom

+44 (0) 1604 936 200

Mon-Fri 6AM-11AM (GMT)

Germany

+49 (0) 69 9579 7960

Mon-Fri 6:00-11:00

Email Us

Customer Support: support@eufylife.com

Anker Innovations Limited

Room 1318-19, Hollywood Plaza, 610 Nathan Road, Mongkok, Kowloon, Hong Kong

@EufyOfficial

@EufyOfficial

@EufyOfficial