

ION

GAME DAY™ PRIMETIME

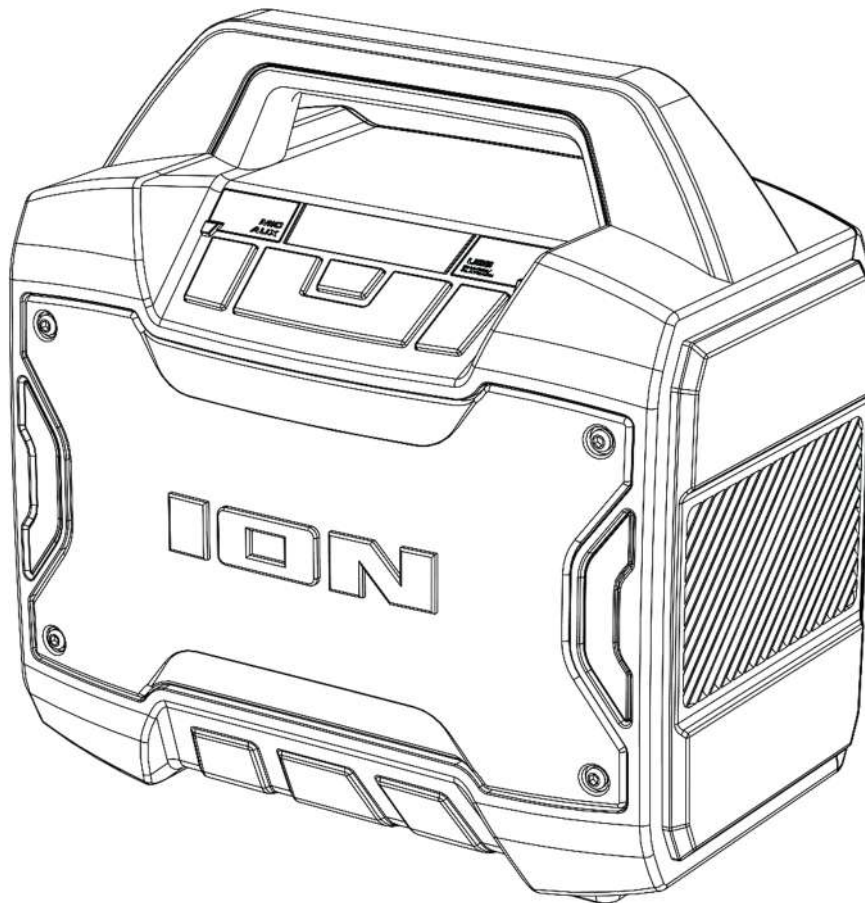

User Guide

English



ionaudio.com/support

TABLE OF CONTENTS

INTRODUCTION	4
Box Contents.....	4
Support.....	4
SETUP	5
Outdoor Use and Care	5
Connection Diagram	5
FEATURES	7
Front Panel	7
Rear Panel.....	10
OPERATION.....	11
App Control.....	11
Bluetooth® Connecting with Game Day™ Primetime	12
Stereo-Link™: Syncing Between Two Speakers.....	13
Using the Radio	15
Connecting an Audio Device Using the Aux Input	16
USB Playback Mode.....	17
Using the USB Charge Port.....	18
TROUBLESHOOTING	19

APPENDIX.....	20
Technical Specifications.....	20
Trademarks & Licenses	20

INTRODUCTION

Thank you for purchasing the Game Day™ Primetime. At ION, your entertainment is as important to us as it is to you. That's why we design our products with one thing in mind—to make your life more fun and more convenient.

Note: Before you first use the product, please fully charge the batteries. Your unit was purposely shipped with a reduced battery charge to ensure safe transit. For optimal charging, power off the speaker while charging.

Use the included USB-A to USB-C® cable to connect the unit to a 5V, 2A power adapter (not included) connected to a power outlet and let it charge for up to 4 hours (depending on the specifications of your adapter). This helps ensure the longest life for your battery.

Box Contents

Game Day™ Primetime

USB-A to USB-C® Charging Cable (3.28 ft / 1 m)

Quickstart Guide

Support

For the latest information about this product (documentation, technical specifications, system requirements, compatibility information, etc.) and product registration, visit ionaudio.com.

For additional product support, visit ionaudio.com/support.

SETUP

Outdoor Use and Care

Though Game Day™ Primetime are water-resistant and able to tolerate splashing water, please review the tips below to get the best performance from your Game Day™ Primetime:

- Bring Game Day™ Primetime indoors during extreme weather.
- Please do not place Game Day™ Primetime in standing water or puddles.
- Please do not attempt to charge Game Day™ Primetime in a wet environment. Make sure the power input, USB cable, power adapter, and power outlet are all completely dry before making any connections.
- **WARNING:** Keep any non-water-resistant devices (phones, music players, etc.) in a dry place where they will not be affected by water and cause a risk of electric shock.

Connection Diagram

For the quickest charging time, power off Game Day™ Primetime and use the included USB-A to USB-C® cable to connect the USB-C® charging port on the rear panel of the speaker to a USB power adapter (DC 5V 2A, not included) connected to a power outlet, or your computer (powered on). A full charge can take up to 4 hours, depending on the specifications of your 5V, 2A adapter.

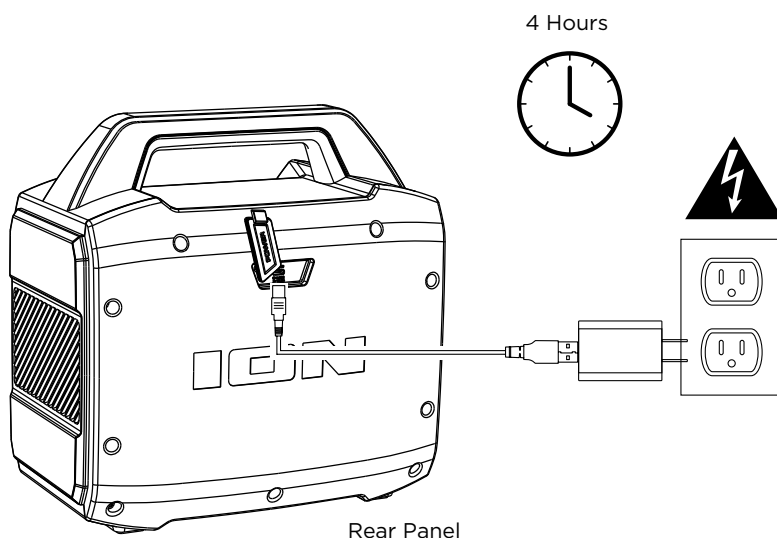

The **lightning bolt** icon on the display will light up when Game Day™ Primetime is connected to a power source and charging. The **battery icon** will fill to display the battery life percentage. When charging is complete, the lightning bolt icon will disappear, and the battery icon will be completely filled.

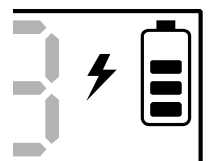

If no audio is played through the Game Day™ Primetime speaker for 15 minutes, the unit will enter a standby mode to conserve battery life. This may mean the Bluetooth signal is paused, no audio is coming through a device connected to the aux port, or the volume is set to zero. To wake the unit, simply resume audio signal or press any button.

After 60 minutes without use, Game Day™ Primetime will fully power off. To resume using it, press and hold the **Power** button to turn the speaker back on.

Here are some other recommendations for getting the longest life from the internal battery.

General Usage Fully charge the battery before using it.

Avoid full discharge of the battery if possible. Li-Ion batteries are maintenance-free, and the battery will last longest when operating between 30–80% charged.

Do not use the product while charging the battery.

Do not charge the battery in exceedingly hot (greater than 90°F/32°C) or exceedingly cold (less than 32°F/0°C) temperatures.

Storage For best product longevity, do not store at exceedingly hot (greater than 90°F/32°C) or exceedingly cold (less than 32°F/0°C) temperatures.

For best product longevity, store with a 50% battery charge.

If you leave the battery level low and do not charge it for 6 months, it may permanently lose capacity.

Repair If the battery fails to charge, contact ION Audio at ionaudio.com.

Disposal Bring the unit to a recycling center or dispose of in accordance with local ordinances.

FEATURES

Front Panel

Click a control below to jump to that section.

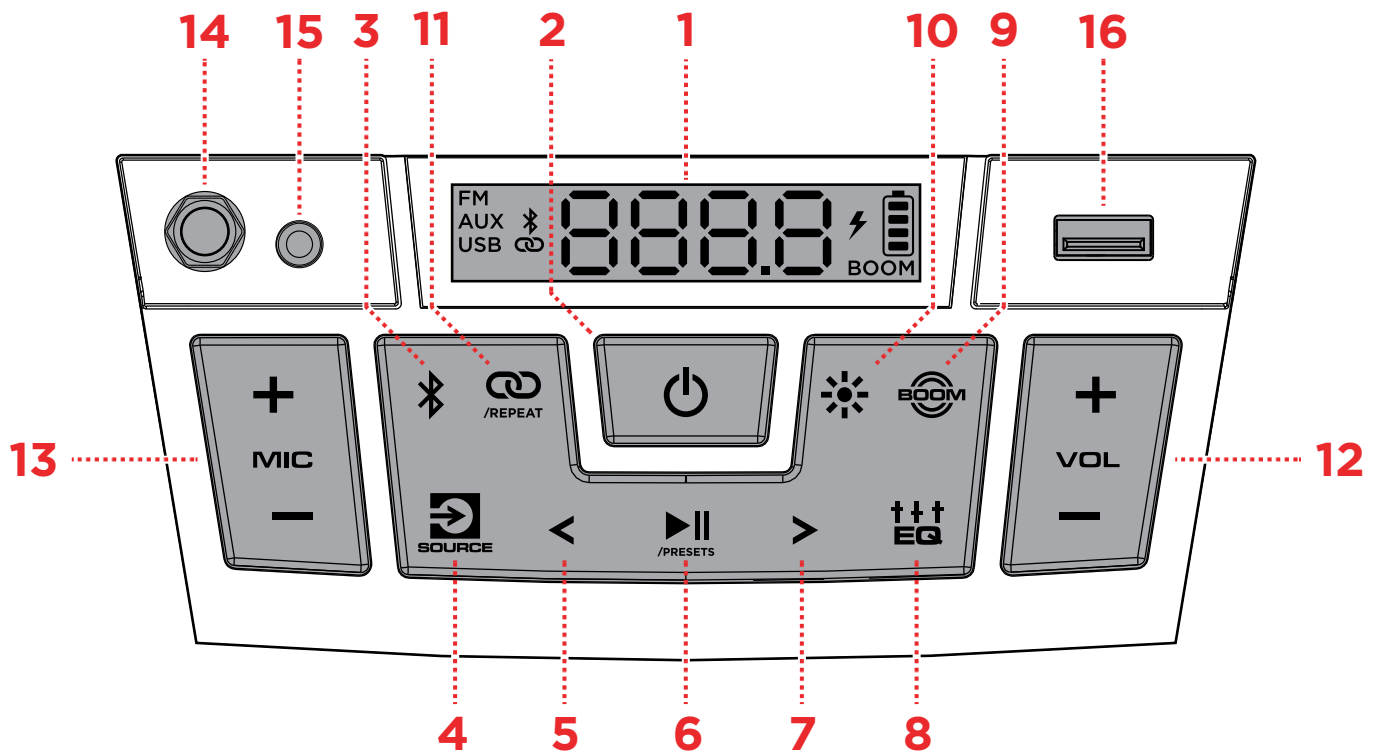

1. Display

This screen shows information relevant to Game Day™ Primetime's current operation:

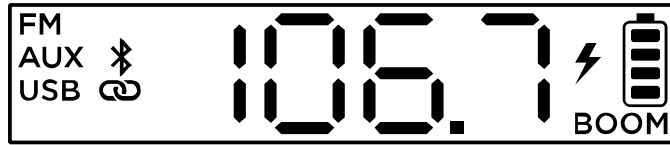

- **Source Icons (FM, AUX, USB):** These icons will indicate whether Game Day™ Primetime is in FM, Aux, or USB playback modes.
- **Bluetooth Icon (📶):** The Bluetooth icon will display when a device is paired to Game Day™ Primetime. See [Operation > Bluetooth® Connecting with Game Day™ Primetime](#) to learn how to connect a Bluetooth device.
- **Stereo-Link™ Icon (🔗):** The Stereo-Link™ icon will display when Game Day™ Primetime is linked to another speaker. The Stereo-Link™ icon will be off when a single speaker is used. See [Operation > Stereo-Link™: Syncing Two Speakers](#) below for instructions on how to link two speakers.
- **Radio Station:** The centered numerals indicate the current radio station that is selected. This area will also show the volume and the current repeat mode when either are changed. See [Operation > Using the Radio](#) for more information.
- **Lightning Bolt Icon (⚡):** The lightning bolt icon will display when Game Day™ Primetime is connected to a power outlet and charging.
- **Battery Indicator (🔋):** The battery icon displays the battery life percentage. When fully charged, the battery icon will be completely filled.
- **BOOM Icon:** The BOOM icon will display when the **Boom Button™** is pressed. The icon will be off when the function is deactivated.

2. Power Button

Press and hold this button to turn Game Day™ Primetime on and off.

3. Bluetooth Button

Press this button to enter Bluetooth pairing mode. When connected to a Bluetooth device, double-press this button to disconnect a paired device and re-enter pairing mode, or single-press to disconnect a paired device and enter Aux mode. See [Operation > Bluetooth® Connecting with Game Day™ Primetime](#) to learn how to connect a Bluetooth device.

Press and hold this button to enable or disable voice prompts.

4. Source Button

Press this button to cycle between FM, USB, and Aux modes.

5. Previous Button

In FM mode, press this button briefly to go to the previous station. Press and hold this button to seek the previous strong station.

In Bluetooth and USB modes, press this button once to go to the start of the current track. Press the button again within one second to go to the previous track.

6. Next Button

In FM mode, press this button briefly to go to the next station. Press and hold this button to seek the next strong station.

In Bluetooth and USB modes, press this button to go to the next track.

7. Play/Pause / Presets Button

Press this button to play and pause Bluetooth or USB audio.

In FM mode, use this button to save and recall radio presets. See [Operation > Using the Radio](#) to learn more.

8. EQ Button

Press this button to cycle through adjusting the Low, Mid, and Hi EQ frequencies, and then press the **VOL +/-** buttons to adjust the level. If no changes are made within five seconds, Game Day™ Primetime will exit EQ adjustment.

9. Boom Button™

Press to simultaneously enhance the bass EQ and volume and activate a light show that pulses to the beat of the music.

10. Lights Button

Press this button to switch between Color Cycle, Beat Sync, and Solid Color light modes, or to turn the lights off.

11. Stereo-Link™ / Repeat Button

See [Operation > Stereo-Link™: Syncing Two Speakers](#) to learn more about syncing two Game Day™ Primetime speakers together using this button.

In USB playback mode, press this button to cycle between repeat modes. See [Operation > USB Playback Mode](#) to learn more.

12. Mic Volume Up/Down Buttons

Press these buttons to adjust the volume of the microphone input. The current volume level will be shown on the display.

13. Volume Up/Down Buttons

Press these buttons to adjust the speaker's volume. The current volume level will be shown on the display.

14. Mic Input

Connect a dynamic microphone (not included) to this input using a 1/4" (6.35 mm) cable. Use the **MIC +/-** buttons to adjust the microphone volume.

15. Aux Input

Connect an MP3 or other audio player to Game Day™ Primetime here using a 1/8" (3.5 mm) auxiliary cable (not included). See [\(4.5\) Operation > Connecting an Audio Device Using the Aux Input](#) for more information.

16. USB-A Playback/Device Charging Port

Connect a USB drive here for USB mode playback. See [\(4.6\) Operation > USB Playback Mode](#) for more information.

Game Day™ Primetime includes a power bank function, which allows you to charge a compatible 5V, 1A smartphone, tablet, or other device using the unit's internal battery (Capacity: 2000mAh/11.1V 22.2Wh) by connecting a cable here. See [\(4.7\) Operation > Using the USB Charge Port](#) for more information.

Rear Panel

Note: To access the rear panel port, pull the tab on the protective rubber panel to release it and access the port.

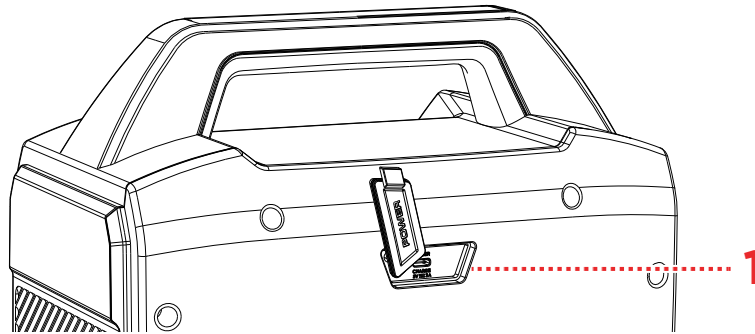

- 1. USB-C® Charging Port:** Connect the USB-C® end of the included cable to Game Day™ Primetime here, then connect the USB-A end to a 5V, 2A USB power adapter (sold separately) and plug it into a power outlet, or your computer (powered on). See [Setup > Charging and Battery Information](#) for more information.

App Control

IMPORTANT: To ensure the best possible experience with the app, use the most current Android OS or iOS on your device.

Follow these steps to download the free app on your device:

1. Open the Apple App Store or Google Play on your device. Then, search for the **ION Sound Control™** app.
2. Follow the on-screen instructions to download and install the app. Once downloaded, the **ION Sound Control™** app will appear on your device's home screen.
3. Connect your device to Game Day™ Primetime via Bluetooth. See [Operation > Bluetooth® Connecting with Game Day™ Primetime](#) to learn how to do this.
4. Open the ION Sound Control™ app. If prompted, allow the app to access your device's Bluetooth and Location Services.
5. Follow the steps on screen to find and connect to your Game Day™ Primetime. Once connected, you can control various functions of the speaker, such as:
 - **Volume:** Adjust the speaker's volume.
 - **EQ:** Adjust the speaker's equalization.
 - **Voice Prompts:** Enable or disable the voice prompts.
 - **Lights:** Change the light modes.
 - **Battery Life:** Check the speaker's battery life status.
 - **Support:** Visit ionaudio.com, contact Technical Support, and view Warranty information and Frequently Asked Questions.

Bluetooth® Connecting with Game Day™ Primetime

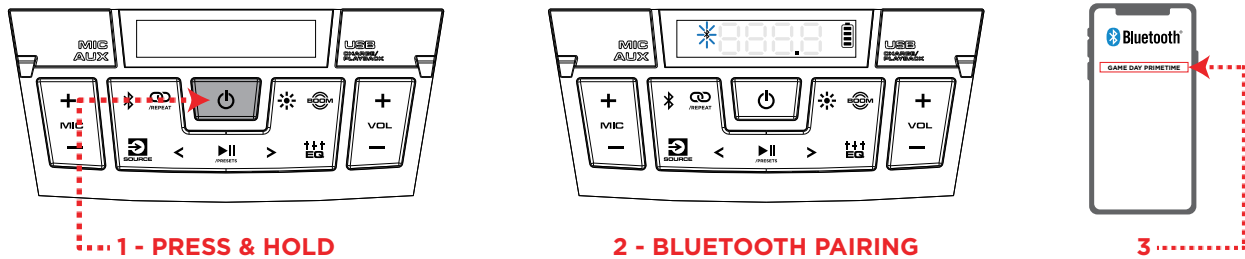

Note: Press and hold the **Bluetooth** button to turn voice prompts on or off.

1. Turn on Game Day™ Primetime by holding down the **Power** button for 2 seconds. Game Day™ Primetime will automatically enter Bluetooth pairing mode the first time it is powered on. After that, it will remember the last mode used and enter that mode when powered on.
2. The Bluetooth icon on the display will flash to indicate it is ready to pair, and you will hear “Bluetooth Pairing” if voice prompts are enabled.
3. Navigate to your device’s Bluetooth setup screen, find **GAME DAY PRIMETIME**, and connect. The **Bluetooth** icon will appear in the display, and you will hear “Bluetooth Connected” (if voice prompts are enabled).

Note: Do not connect to **iPA162_BLE**; this is reserved exclusively for connecting to the ION Sound Control™ app. If you experience trouble in connecting, select “Forget this Device” on your Bluetooth device and try to connect again.

4. Now you can use the buttons on the front panel to control audio playback:
 - Press the **Play/Pause / Presets** button to play or pause the current track.
 - Press and quickly release the **VOL +** button to increase the volume.
 - Press and quickly release the **VOL -** button to decrease the volume.
 - Press the **>** button to skip to the next track.
 - Press the **<** button to revert to the beginning of the current track. Repeat this action within one second to skip to the previous track.

To disconnect a paired device, do any of the following:

- Turn off Bluetooth from your device’s Bluetooth settings. The speaker will enter Bluetooth pairing mode to make it available for another device.
- Double-press the Bluetooth button to disconnect and re-enter pairing mode.
- Briefly press the Bluetooth button to disconnect and enter Aux mode.

Once you have disconnected, the Bluetooth icon will return to flashing, and you will hear “Bluetooth Disconnected” if voice prompts are enabled.

Stereo-Link™: Syncing Between Two Speakers

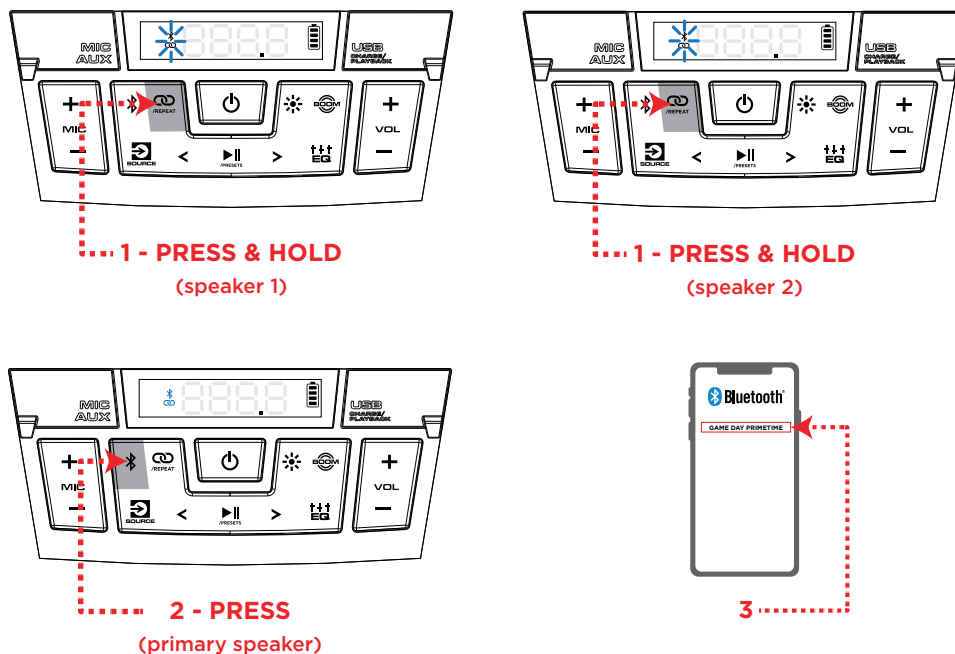

To sync audio between two Game Day™ Primetime speakers:

Note: When you begin the Stereo-Link™ process, any connected Bluetooth devices will be automatically disconnected. You can also disconnect your device prior to beginning by double-pressing the Bluetooth button.

1. Press and hold the **Stereo-Link™ / Repeat** button on each Game Day™ Primetime speaker. A beeping sound will be heard and the **Stereo-Link™** and **Bluetooth** icons in each unit's display will begin flashing while attempting to link. Please allow 10 to 30 seconds for the speakers to link.

Note: Speakers should be within 50' (15 m) of each other to properly link. The closer the speakers are, the faster they will link.

Note: To exit Stereo-Link™ mode, double-press the **Stereo-Link™ / Repeat** button again.

Once the speakers are linked, the **Stereo-Link™** icons on both speakers will be lit solidly, and the Bluetooth icons will flash to indicate it is searching for a device to pair with.

2. Select which unit will be the “primary” speaker by pressing and releasing the **Bluetooth** button on that unit.
3. Navigate to your device's Bluetooth settings menu and select **GAME DAY PRIMETIME** to connect.

When the connection is successful, you will hear “Bluetooth Connected” from the primary speaker (if voice prompts are enabled). When Bluetooth audio playback begins, you should hear it through both speakers. The primary speaker will play the left channel while the secondary speaker plays the right channel. Playback controls are active on both speakers.

Note: Radio, Aux, and USB modes will be disabled when Stereo-Link™ is active.

To exit Stereo-Link™ mode, double-press the Stereo-Link™ / Repeat button. The primary speaker will remain paired to your Bluetooth device. The secondary speaker will begin searching for a new Bluetooth device to pair to, and you will hear "Bluetooth Pairing" if voice prompts are enabled.

Note: Pressing and holding the Power button on the primary speaker while in Stereo-Link™ mode will power off all connected speakers. Game Day™ Primetime speakers powered off in Stereo-Link™ mode will automatically enter Stereo-Link™ mode the next time they are powered on and begin searching for secondary speakers to connect to.

Using the Radio

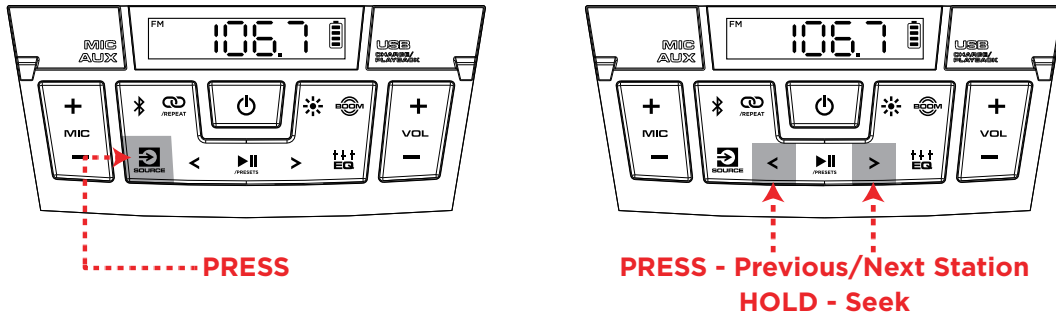

To use the radio, press the **Source** button so that **FM** is selected and shown on the display.

While in FM mode, briefly press the **Previous** and **Next** buttons (</>) to move to the previous or next station. Press and hold the </> buttons to seek for the next strongest station in that direction.

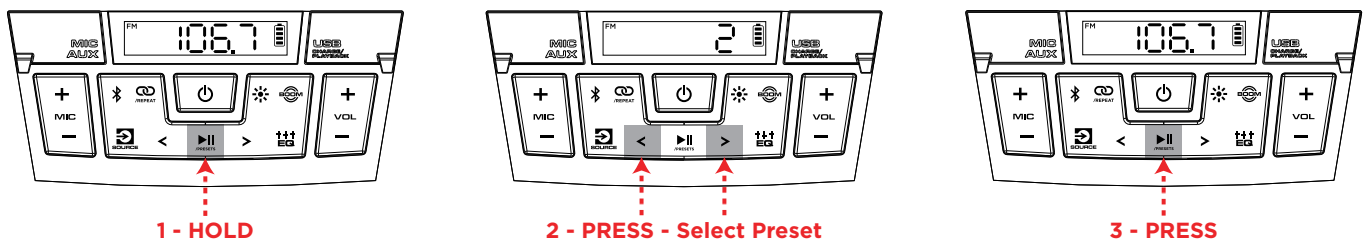

To save a radio station as a preset:

1. Press and hold the **Play/Pause / Presets** button.
2. Use the </> buttons to select a preset number, 1-12, shown on the display.
3. When you have selected the desired preset number, quickly press and release the **Play/Pause / Presets** button again to save it.

To recall a previously saved preset, briefly press the **Play/Pause / Presets** button to cycle between the 12 presets.

Connecting an Audio Device Using the Aux Input

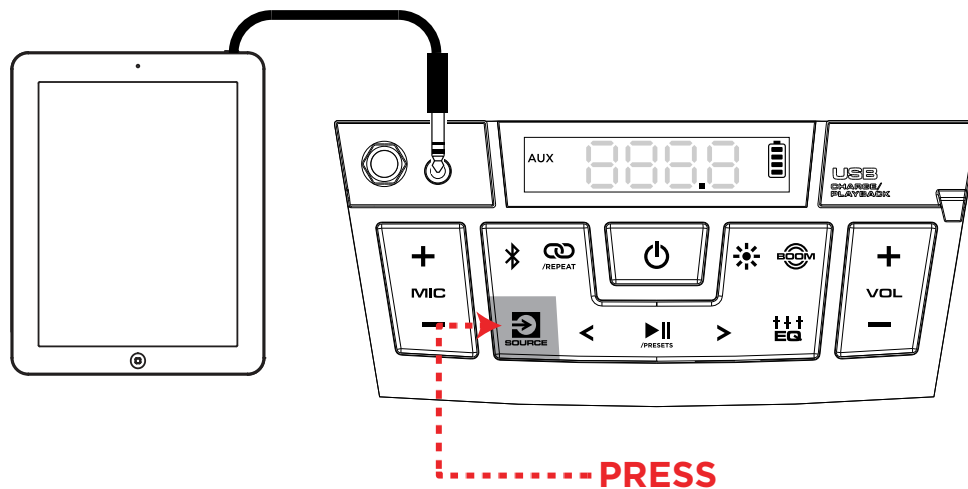

1. Connect a 1/8" (3.5 mm) auxiliary cable to the input on the front panel of Game Day™ Primetime and connect the other end to an audio device such as an MP3 or CD player.
2. Press the **Source** button so that **AUX** is selected and shown on the display. Doing so will also cause Bluetooth devices to disconnect.
3. Press play on your device's music player. Use the **Volume Up/Down (+/-)** buttons to adjust the Aux volume.

Note: The Game Day™ Primetime speaker volume controls act independently from your connected device. Lower the volume on your device if signal distortion occurs.

To exit **Aux mode**, press the **Source** button to switch to FM or USB playback, or press the **Bluetooth button** to reconnect to a Bluetooth device.

USB Playback Mode

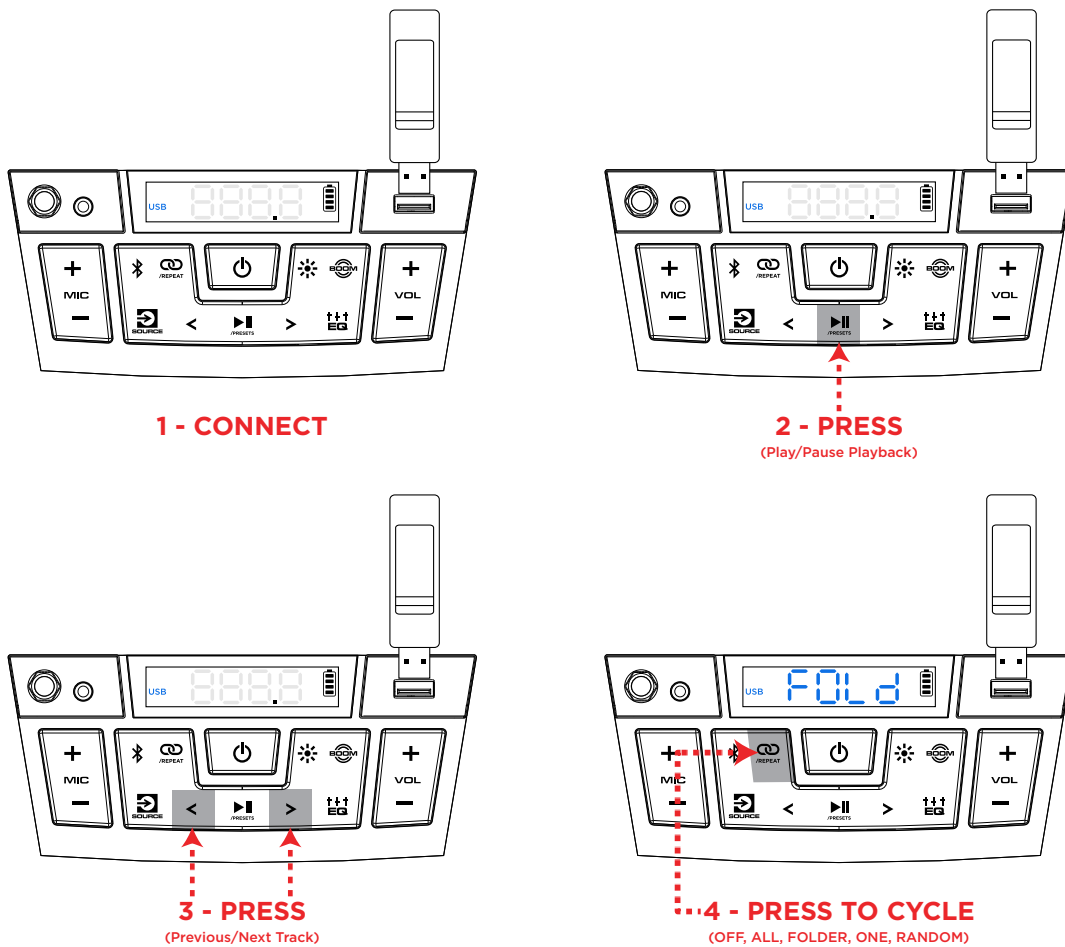

Connect a USB drive to the USB-A port on the front panel of Game Day™ Primetime to play music files. USB Mode will be automatically selected, and music files will begin playing.

While in USB playback mode, you can use the following buttons on the front panel to control playback:

- Press the **Play/Pause / Presets** button to start or stop USB playback.
- Use the **Previous** and **Next** buttons (</>) to skip to the previous or next USB track.
- Briefly press the **Stereo-Link™ / Repeat** button to cycle between repeat modes, as shown on the display:
 - o **ALL:** Repeats all tracks on the USB drive.
 - o **FOLd:** Repeats all tracks in the current folder of the USB drive.
 - o **OnE:** Repeats the currently playing track.
 - o **rAn:** Randomly shuffles the track order.

Using the USB Charge Port

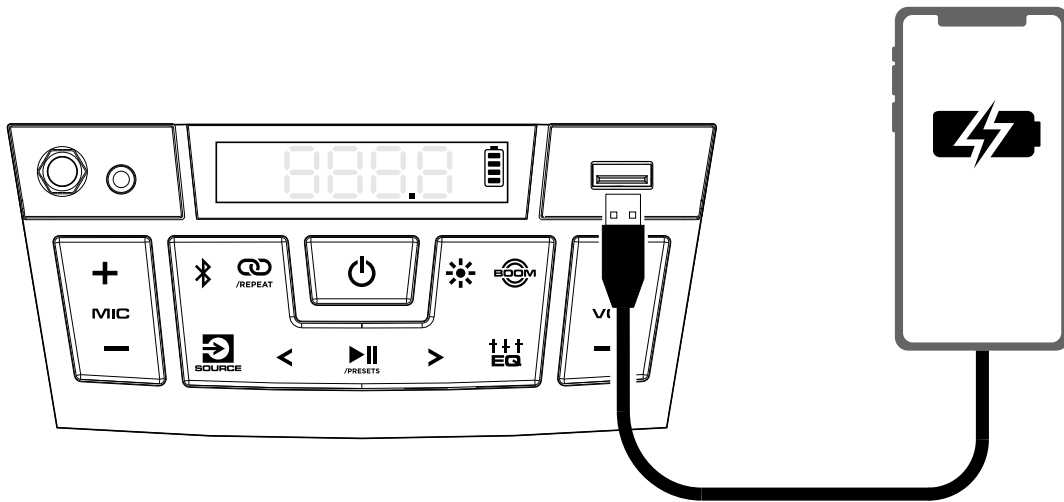

To use the USB charge port:

1. Connect a USB type-A cable to the **USB Charge Port** on the front panel of your Game Day™ Primetime (see image).
2. Connect the other end of the cable to the charging input on your smartphone, tablet, or other compatible device.

TROUBLESHOOTING

If the unit is not charging: Make sure the USB-C® charging cable is properly connected to the power input, the power adapter, and the power outlet.

If the sound is distorted: Try lowering the volume control of your sound source.

If there is too much bass: Try adjusting the tone or EQ control on your sound source or on Game Day™ Primetime to lower the bass level. This will allow you to play the music louder before clipping (distortion) occurs. You can also check to make sure the BOOM function is off.

If you cannot connect your audio device to Game Day™ Primetime via Bluetooth:

- Have your audio device (e.g., smartphone or tablet) and Game Day™ Primetime as close together as possible while trying to connect. Make sure both the audio device and Game Day™ Primetime are unobstructed by walls, furniture, etc.
- Double-press the Bluetooth button to disconnect Game Day™ Primetime from any other audio device and restart the search process. If this does not work right away, power off Game Day™ Primetime and then power it back on. See [Operation > Bluetooth Connecting with Game Day™ Primetime](#) for more information.
- Reset the Bluetooth connection on your audio device by turning Bluetooth off and back on. You can find this under the Bluetooth menu in the Settings for your phone or other audio device.

If this does not work, and you have connected to Game Day™ Primetime before, find Game Day™ Primetime in the list of available or previously connected devices in your audio device's Bluetooth menu, tap the "gear" or "i" icon located next to it and then select **Unpair** or **Forget**. Turn Game Day™ Primetime off and back on and try pairing again once it reappears in your available devices list.

Note: If Game Day™ Primetime has been paired to another audio device recently that is still within range, you may need to repeat this process with that audio device to fully disconnect.

If you experience audio dropouts while playing music from a Bluetooth device, this may be happening because your unit is trying to link to another speaker. This can occur if you power off a speaker that was linked to your unit or if you have just turned on your unit and it is in Stereo-Link™ mode. To stop the audio dropouts, exit Stereo-Link™ mode by double pressing the **Stereo-Link™ / Repeat** button. Alternatively, you can wait for your unit to link to another speaker if there is one within range.

APPENDIX

Technical Specifications

Output Power	60 W (peak)
Drivers	5.25" (135.35 mm) woofer 2" (50.8 mm) tweeter
Bluetooth Specifications	Profile: A2DP, AVRCP Bluetooth Version: 5.0 Range: Up to 100 ft. (30.5 m) * Stereo-Link™ Range: Up to 50 ft. (15 m) between speakers
Battery	Capacity: 2000mAh/11.1V, 22.2Wh Battery life: Up to 15 hours ** Charge Time: Up to 4 Hours
Dimensions <small>(width x depth x height)</small>	11.93" x 7.13" x 11.61" 303 mm x 181 mm x 295 mm
Weight	7.14 lbs. 3.24 kg

Specifications are subject to change without notice.

* Bluetooth and wireless reception and range are affected by walls, obstructions, and movement. For optimal performance, place the product so it is unobstructed by walls or furniture and is raised off the ground.

** Battery life may vary based on temperature, age, and volume usage of product.

Trademarks & Licenses

ION Audio is a trademark of inMusic Brands, Inc., registered in the U.S. and other countries.

The *Bluetooth* word mark and logos are owned by the Bluetooth SIG, Inc., and any use of such marks by ION Audio is under license.

App Store is a trademark of Apple Inc., registered in the U.S. and other countries.

Android and Google Play are registered trademarks of Google Inc.

USB Type-C, USB and USB-C are trademarks (or registered trademarks) of USB Implementers Forum, Inc., in the U.S. and other countries.

All other product names, company names, trademarks, or trade names are those of their respective owners.



ionaudio.com